

2012-2013 Catalog

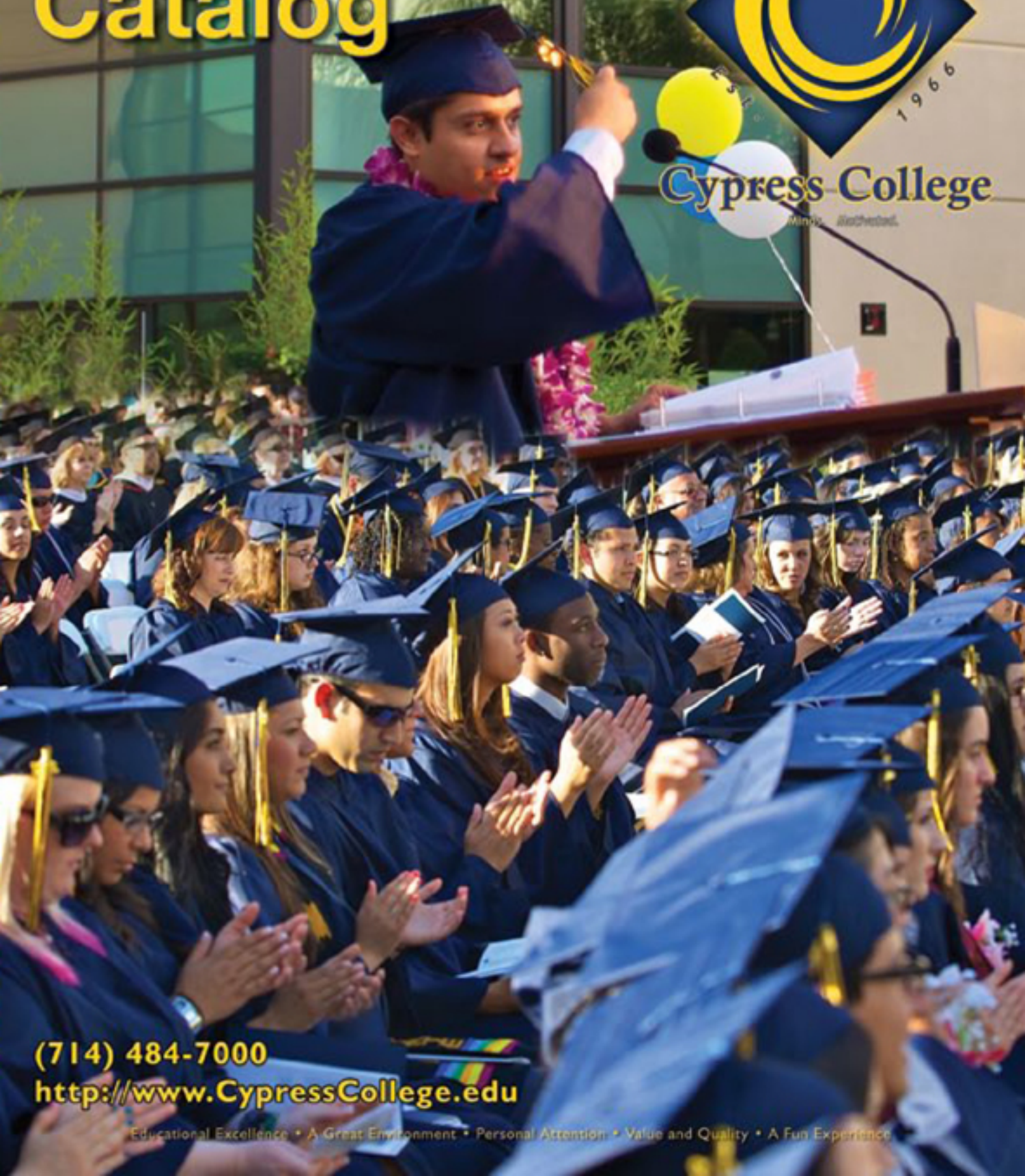

Cypress College

Minds. Interacted.



(714) 484-7000

<http://www.CypressCollege.edu>

Educational Excellence • A Great Environment • Personal Attention • Value and Quality • A Fun Experience

Welcome to Cypress College



It is my sincere pleasure to welcome you to Cypress College, where student success is our first priority. We are proud of our reputation for academic excellence, for the breadth and depth of our career and technical education programs, and for offering high-quality and student focused support services. At Cypress College, our award-winning faculty is recognized for providing students with individual attention and guidance, utilizing a variety of teaching approaches and methodologies to help you to succeed. Students will discover here a rich academic environment designed to nurture and support success.

Our academic and vocational programs are supported with a wide array of services. Among these are assessment, counseling and guidance, study skills classes, a library and learning center for individual and group study and tutoring, financial aid, and health services, to name a few. Our intercollegiate athletics teams compete at the highest levels, earning numerous state championships over the years. We encourage students to participate in our performing arts programs and student government activities, and to broaden their experiences by becoming involved with a variety of college clubs that are connected to their academics or to community involvement.

Cypress College has benefitted greatly from the support of the local community and has utilized bond revenue approved by the voters to improve and beautify the campus. Our Library, Student Center, Bookstore and newly remodeled Humanities Building all came into being as a result of community support and

are state-of-the-art facilities serving students' needs. Our vocational and career programs are strongly connected to our business community and provide instructional opportunities for students utilizing modern and current equipment.

We invite you to become a part of this community of learners. I believe that you will find Cypress College to be a warm and inviting institution, a place that nurtures student achievement and encourages student involvement. I look forward to seeing you here at the College, pursuing your dreams and achieving your goals in the spirit of excellence, integrity, collegiality, and inclusiveness that characterizes all we do.

Bob Simpson, Ed. D.
President

North Orange County Community College District

1830 W. Romneya, Anaheim, CA 92801

(714) 808-4500

Cypress College is a member of the North Orange County Community College District (NOCCCD). The District also includes Fullerton College, the oldest California community college in continuous operation, and three Continuing Education Centers located in Anaheim, Cypress, and Fullerton.

The North Orange County Community College District came into existence on July 1, 1965, with Fullerton College already in operation and plans for a college in the western part of the district. Cypress College opened on September 12, 1966, just 74 days after the land was acquired.

Encompassing approximately 155 square miles, the North Orange County Community College District has a population of about one million. In general, the district includes the following communities: Anaheim, Brea, Buena Park, Cypress, Fullerton, La Habra, La Palma, Los Alamitos, Placentia, Rossmoor, and Yorba Linda. Portions of the following communities are included: Garden Grove, La Habra Heights, La Mirada, Orange, Seal Beach, Stanton, Whittier, and unincorporated territory in both Los Angeles and Orange counties. It serves, in its credit and non-credit programs, about 70,000 students each semester.

The North Orange County Community College District is part of the California Community College system, one of three segments of public postsecondary education in the state. A seven-member Board of Trustees, elected by the citizens of the district, governs all programs and activities of the NOCCCD.

Board of Trustees

Jeffrey P. Brown
Barbara Dunsheath
Leonard L. Lahtinen
Michael B. Matsuda
Molly McClanahan
Donna Miller

M. Tony Ontiveros
Student Trustees:

Alie McCaskill — Cypress College
Gabael Botello — Fullerton College
Chancellor
Ned Doffoney, Ed.D.



Cypress College

Catalog

2012–2013

9200 Valley View Street
Cypress, California 90630
(714) 484-7000
www.CypressCollege.edu

Volume Forty-Seven
Published Annually July, 2012
Price \$8 per copy (\$10 mailed)

Cypress College is accredited by the Accrediting Commission for Community and Junior Colleges of the Western Association of Schools and Colleges, (10 Commercial Blvd., Ste. 204, Novato, CA 94949, 1-415-506-0234, Fax 1-415-506-0238, <http://www.acscwasc.org/index.htm>), an institutional accrediting body recognized by the Commission on Recognition of Postsecondary Accreditation and the U.S. Department of Education.

The College Catalog is a publication of the Cypress College Office of Instruction

Photo credits: Marc S. Posner

Table of Contents

Academic Calendar	3
About Cypress College	4
Admissions Requirements	6
Registration	7
Academic Policies	8
Distance Education Program	25
Instructional Support Services	26
Special Programs	27
Student Support Services	32
Campus Life	38
Administrative Procedures	40
Programs of Study	48
Graduation/Educational Options	50
Programs/Course Descriptions	67
Faculty	287
Administration/Organizational Structure	288
Quick Guide to Help You	304
Index	307
Campus Map	Inside Back Cover

*Academic Calendar 2012–2013

Effective Fall 2012, the college will operate on a 16-week semester.

2012 Fall Semester — August 27–December 15, 2012

August 27	First Day of Instruction
September 3	Legal Holiday — Labor Day
November 12	Legal Holiday — Veterans' Day
November 22, 23, 24, 25	Legal Holiday — Thanksgiving Recess
December 15	End of Fall Semester
December 24, 2012–February 4, 2013	Academic Recess between Semesters

2013 Spring Semester — February 4–May 31, 2013

January 2, 2013–February 1, 2013	Winter Intersession
January 21	Martin Luther King Holiday
February 4	First Day of Instruction
February 15	Legal Holiday — Lincoln's Birthday (No classes Saturday 18th or Sunday 19th)
February 18	Legal Holiday — Presidents' Day
March 25–March 29	Spring Recess (No classes Saturday 30th or Sunday 31st)
May 27	Observed Legal Holiday — Memorial Day
May 31 (tentative)	Commencement
May 31	End of Spring Semester

2013 Summer Session — to be announced

*Dates and deadlines are subject to change.

July 2012–June 2013

2012

JULY							AUGUST							SEPTEMBER						
S	M	T	W	T	F	S	S	M	T	W	T	F	S	S	M	T	W	T	F	S
1	2	3	4	5	6	7				1	2	3	4							1
8	9	10	11	12	13	14	5	6	7	8	9	10	11	2	3	4	5	6	7	8
15	16	17	18	19	20	21	12	13	14	15	16	17	18	9	10	11	12	13	14	15
22	23	24	25	26	27	28	19	20	21	22	23	24	25	16	17	18	19	20	21	22
29	30	31					26	27	28	29	30	31	23	24	25	26	27	28	29	
													30							

OCTOBER							NOVEMBER							DECEMBER							
S	M	T	W	T	F	S	S	M	T	W	T	F	S	S	M	T	W	T	F	S	
												1	2	3							1
7	8	9	10	11	12	13	4	5	6	7	8	9	10	2	3	4	5	6	7	8	
14	15	16	17	18	19	20	11	12	13	14	15	16	17	9	10	11	12	13	14	15	
21	22	23	24	25	26	27	18	19	20	21	22	23	24	16	17	18	19	20	21	22	
28	29	30	31				25	26	27	28	29	30	23	24	25	26	27	28	29		
													30	31							

2013

JANUARY							FEBRUARY							MARCH							
S	M	T	W	T	F	S	S	M	T	W	T	F	S	S	M	T	W	T	F	S	
												1	2							1	2
6	7	8	9	10	11	12	3	4	5	6	7	8	9	3	4	5	6	7	8	9	
13	14	15	16	17	18	19	10	11	12	13	14	15	16	10	11	12	13	14	15	16	
20	21	22	23	24	25	26	17	18	19	20	21	22	23	17	18	19	20	21	22	23	
27	28	29	30	31			24	25	26	27	28	24	25	26	27	28	29	30			
													31								

APRIL							MAY							JUNE								
S	M	T	W	T	F	S	S	M	T	W	T	F	S	S	M	T	W	T	F	S		
												1	2	3	4							1
7	8	9	10	11	12	13	5	6	7	8	9	10	11	2	3	4	5	6	7	8		
14	15	16	17	18	19	20	12	13	14	15	16	17	18	9	10	11	12	13	14	15		
21	22	23	24	25	26	27	19	20	21	22	23	24	25	16	17	18	19	20	21	22		
28	29	30					26	27	28	29	30	31	23	24	25	26	27	28	29			
													30									

Cypress College has made every reasonable effort to determine that everything stated in this Catalog is accurate. This publication is prepared in advance of the time period it covers; therefore, changes in courses and programs offered, together with other matters contained herein, are subject to change without notice by the administration of Cypress College.

Cypress College

VISION STATEMENT

A premier learning community recognized for supporting student success and enriching society.

MISSION STATEMENT

Cypress College enriches students' lives by providing high-quality education for transfer to four-year institutions, associate degrees, career technical education, and certificate coursework, as well as basic skills and opportunities for lifelong learning. The college is committed to promoting student learning and success, embracing diversity, and contributing to both the economic and social development of the surrounding community.

EXCELLENCE IN EDUCATION

Cypress College emphasizes education for the individual student. Excellence of instruction and individualized learning laboratories enhance the possibility for students to achieve their highest potential. In addition, a staff of tutors and full-time counselors provides instructional support and extensive guidance information to aid students in their choice of programs and classes. For the student who plans to complete a Baccalaureate degree, the college provides a smooth transition from high school to colleges and universities.

Numerous occupational programs are available for the student who desires preparation for immediate employment. Each occupational program is planned with the aid of a local advisory committee to insure relevance to changing career opportunities in each area of employment.

The College is composed of twelve major instructional buildings located on a 110-acre site. The campus buildings contain conventional classrooms as well as laboratory facilities for science, art, computer technology, photography, automotive services, dental clinic, mortuary science, physical education and other specialized programs. The college's Educational Services provide opportunities for students with disabilities to be fully integrated into various college programs.

In addition to these instructional facilities, the campus is provided support services by a bookstore, and food service centers. There are nine parking lots with an aggregate of 4,000 parking spaces designed to service students and staff, with an appropriate number of spaces reserved for the disabled.

Cypress College serves the educational needs of its entire community by providing a variety of occupational programs, transfer programs, and special interest classes. The College offers something for everyone, regardless of the student's individual background or educational goals. Since opening in 1966, Cypress' population has grown from an original enrollment of 1,200 to a student population of almost 15,000.

CORE VALUES

Cypress College is committed to:

- Excellence** — quality and high standards in instruction and student services, supported by professional growth for faculty and staff
- Integrity** — an ethical standard that emphasizes honesty, fairness, accountability, and trust
- Collegiality** — an environment that emphasizes teamwork, collaboration, communication, courtesy and respect both on campus and with the surrounding community
- Inclusiveness** — a community that embraces diverse individuals; provides an accessible, supportive climate; and encourages a variety of perspectives and opinions

STRATEGIC PLAN DIRECTIONS

Direction 1: The District will annually improve the rates of completion for degrees, certificates, diplomas, transfers, transfer-readiness requirements, and courses.

Direction 2: The District will annually make progress toward eliminating the documented achievement gap among race/ethnicity groups.

Direction 3: The District will annually improve the success rate for students moving into:

- The highest level possible credit basic skills courses in mathematics, English, and English as a Second Language from noncredit basic skills instruction in the same discipline
- College-level courses in mathematics, English, and English as a Second Language from credit or noncredit basic skills instruction in these disciplines and
- The next higher course in the sequence of credit or noncredit basic skills courses in mathematics, English, and English as a Second Language

Direction 4: The District will implement best practices related to planning, including transparent decision-making processes, support of strategic and comprehensive planning activities at campus and district levels, and the allocation of resources to fund planning priorities

Direction 5: The District will develop and sustain collaborative projects and partnerships with the community's educational institutions, civic organizations, and businesses

CYPRESS COLLEGE INSTITUTIONAL LEARNING OUTCOMES

Approved by Academic Senate on May 11, 2012, and by the President's Advisory Council on May 18, 2012

Students leaving Cypress College will demonstrate common learning outcomes according to the pathway they have chosen: transfer, degree, GE certification; career and technical certification and/or licensure; and/or life-long learning. These Institutional Learning Outcomes encompass the whole student experience. Cypress College uses these ILOs to connect or link student learning outcomes at the course and program levels in instruction, student support services, and learning support services to the overall mission of the college and the success of our students.

Pathway I: Associate Degree and/or CSU/IGETC Transfer Curriculum

I. Breadth of Knowledge, Experiences, and Skills

- Humanities and the Arts: aesthetic awareness, critical analysis, creativity, human reason and culture
- Science, Technology, Engineering, and Mathematics: scientific principles, scientific method, mathematical systems
- Social Sciences: cultural competence, global perspective, human experience
- Physical Education: fitness, health and nutrition, movement competence

II. Communication

- Reading: comprehending, interpreting, and/or evaluating various written information
- Writing: communicating thoughts, ideas, information and messages in appropriate writing
- Listening: perceiving and responding to verbal and/or nonverbal messages
- Communicating: organizing ideas and communicating verbal and/or nonverbal messages appropriate to audience in group setting

III. Critical Thinking and Information Competency

- Analysis: application of rules and principles to new situations, use of logic to draw conclusions, differentiation of facts/inferences/assumptions/conclusions
- Computation: Using basic numerical concepts, tables/graphs/charts, and basic geometrical shapes
- Research: effectively and ethically acquiring information and data through print and electronic technology, and then organizing, analyzing, evaluating, synthesizing, and communicating information
- Problem-Solving: defining a problem, creating a plan of action to resolve problem, executing and evaluating the effectiveness of the plan

IV. Personal, Academic, and Professional Development

- Self-Integration: Understanding the person as an integrated physiological, social, and psychological being
- Personal Responsibility: Self-assessment, development of skills, identifying values and developing goals for personal, academic, and professional growth and life-long independent learning
- Global Citizenship: Understanding the interconnection between current events, ethics, and personal and societal choices within our world

Pathway II: Career and Technical Education Certification

I. Breadth of Knowledge, Competencies, and Skills

- Acquisition of a specified set of principles and skills required for a particular profession, industry, or employment opportunities
- Achievement of the necessary competencies to enter a particular employment field

II. Communication in a Particular Field or Employment

- Comprehending, interpreting, and/or evaluating written information
- Communicating thoughts, ideas, information, and messages in writing appropriate to a career
- Communicating ideas and verbal and/or nonverbal messages in the language, mode, and/or medium of a particular field according to industry standards

III. Analytical Thinking, Problem-Solving, and Information Competency

- Diagnosis, analysis, and application of rules and principles of a particular profession according to professional or industry standards
- Use of numerical concepts, tables/graphs/charts, and numerical principles for computation in a particular field
- Defining a problem, creating a plan of action to resolve problem, executing, and evaluating the effectiveness of the plan in a particular field of employment
- Effectively and ethically acquiring information and data through print and electronic technology, and then organizing, analyzing, evaluating, synthesizing, and communicating information
- Effectively, efficiently, and ethically utilizing current and learning emerging technologies of a particular field of employment

IV. Personal, Academic, and Professional Development

- Self-assessment, development of skills, identifying values and developing goals for personal, academic and professional growth, career resilience, and life-long independent learning
- Demonstration of professional and ethical responsibilities of the individual
- Awareness of additional educational and career opportunities within a particular field and an understanding of the life-long learning requirements of the field

Pathway III: Personal, Academic, and Professional Development

Personal Responsibility

Self-assessment, identification and development of skills and goals for personal, academic, and professional growth and life-long independent learning

Admissions Requirements

Admission to Cypress College is governed by the laws of the State of California and such supplementary regulations as have been prescribed by the Board of Trustees.

The following people are eligible to enroll in Cypress College:

- Any high school graduate OR
- Any person possessing a California high school proficiency certificate OR
- Any person 18 years of age or older who may benefit from instruction OR
- Any K–12 student who qualifies for the Special Admit Program. (Refer to the Special Admit section of this Catalog)

Residency Determination for Tuition Purposes

All students who apply for admission to Cypress College are classified as California residents or non California residents for tuition purposes. Residents and nonresidents are charged according to the perspective fees set by the Board of Governors of the California Community College system.

“Resident students” are those who have resided within California for at least one year prior to the residence determination date and have met the residency standards stipulated in Title 5 of the California Administrative Code. The “residence determinate date” is the day immediately preceding the opening day of instruction each semester or summer session during which the student proposes to attend college in the North Orange County Community College District.

Generally, residency requires actual physical presence in California coupled with the intent to become a resident. One’s state of mind is subjective; hence, it is necessary to look at objective indications of the student’s intent. Examples of evidence that aid the college admissions officer in identifying that intent, but are not individually decisive, are:

- a California driver’s license
- a receipt for registration to vote in California
- a current lease or rental agreement showing the student’s name and address
- a state or federal income tax information document showing a California address
- exceptions apply under certain conditions to active members of the armed forces

“Nonresident students” are those who have not established California residency status in the state for at least one year prior to the residence determination date or those who hold certain non-immigrant visas that preclude them from establishing residency. Foreign students admitted to the United States under student visas are classified as nonresidents.

The California Education Code and provisions in state law allow certain nonresidents the opportunity to pay in-state tuition. Students who believe they are eligible for an exemption based on any one of the following criteria should consult the Admissions and Records Office when they apply for admission to the college.

Note: In order to determine residency status, students must bring all immigration documents, including visas, passports, and I-688 information to the Admissions and Records Office at the time of applying to the college. No single item may establish a case for California residency. It is up to the applicant to provide as many documents as possible to prove validity of a change to California residency.

AB540 allows students, including undocumented immigrant students who meet the requirements of the Education Code, to be exempt from nonresident tuition in California’s universities and colleges.

In order to qualify for this exemption a student must have attended and/or graduated from a California public or private high school after three or more years. The attainment of a GED or certificate of high school proficiency would also exempt the student from paying nonresident tuition. Students living outside the State of California and enrolled in distance education courses are not eligible for the AB540 exemption.

All students seeking this exemption must file an affidavit and high school transcripts with the college. The affidavit is included in the California Nonresident Tuition Exemption form which is available at the Admissions and Records Office.

Specific information regarding residency can be obtained from the Admissions and Records Office. Additional details can be obtained from the college website, the California Education Code and the California Code of Regulations, Title 5.

Open Enrollment Policy

In conformity with the provisions of Title 5 of the California Administrative Code, it is the policy of the Board of Trustees of the North Orange County Community College District that, unless specifically exempted by statute, every course, course section or class, wherever offered and conducted throughout the District, shall be fully open to enrollment and participation by any person who is eligible for admission to the college and meets the stated prerequisites.

Application Procedure

Students who are enrolling in the North Orange County Community College District for the first time and those who are returning after an absence of a semester or more (not including summer) must submit the online admissions application, known as CCCApply. The online application can be accessed on the college website, www.CypressCollege.edu. Students who withdrew from the college during the first three weeks of a term must also submit a new application.

Applications for admission will be accepted beginning March 1 for Summer and the Fall semester and beginning October 1 for the Spring semester.

Registration

Registration appointments are established for each student according to the date and time the student submitted the online admissions application. Although students can register after their assigned date and time, registering on their specific date provides a better selection of classes; however, enrollment is not guaranteed into any class.

A registration email is sent to all new, returning and continuing students. The email indicates the earliest date and time the student can register for classes. Students can also view their registration date and time under Personal Announcements of myGateway's student tab.

Certain registration and admission deadlines must be established. These deadlines are necessary in order to comply with state attendance laws and must be followed by Faculty and students. Failure to comply with these deadlines may mean that the student will not be allowed to attend or receive credit for the class.

New Students

New students are those who have never registered for classes at Cypress or Fullerton College. They must submit the online admissions application. Most new students are required to participate in an assessment and orientation session prior to registering for classes. It is recommended that official transcripts from high school and other colleges are submitted to Cypress College for possible prerequisite clearance.

Returning Students

Returning students are those who have previously attended Cypress or Fullerton College but are returning after an absence of a semester or more (excluding Summer). They must submit the online admissions application. It is recommended that official transcripts from other colleges be submitted to Cypress College for possible prerequisite clearance.

Continuing Students

Continuing Students are those students who were registered in a class at Cypress or Fullerton College the previous semester long enough to have a grade (A, B, C, D, F, I, IP, P, NP) or a withdrawal (W) posted to their transcript. They do not need to submit the online admissions application. Continuing students are given priority registration based on the number of units completed at Cypress and Fullerton Colleges. Those who were registered during the semester but did not complete a course with a letter grade or "W" will have forfeited their continuing student status. They must submit a new online admissions application and will initially be classified as a Returning student.

Assessment

In order to be placed in appropriate class levels students are evaluated and assessed in the areas of English, ESL, reading, writing and mathematics. Students should consult the Assessment Center about placement tests taken at other colleges. The Assessment Center is one of the main components of matriculation services offered to each student.

Counseling/Orientation

Students are strongly advised to meet with a counselor prior to registration. Counselors are well informed in various fields of study and can assist students in long-range planning for specific educational plans. New students are required to attend an orientation to receive important information on offered programs, policies and registration procedures. Orientation appointments are made at the conclusion of the assessment testing. Students can attend an in-person orientation or elect to complete an orientation online.

myGateway

myGateway is the web portal that enables students to view their registration times, class schedules, grades, academic history, added or dropped classes, and access a variety of useful resources. A student ID number and Personal Identification Number (PIN) is needed to log into myGateway which can be accessed on the college website.

Fees

ASSOCIATED STUDENTS BENEFITS PROGRAM

– *More than just a sticker, an opportunity!*

The Cypress College A.S., in addition to acting as a voice for the student body, has put forth an exciting and valuable benefits program. For a modest fee of \$7.00 per semester, a sticker may be bought that entitles the holder to privileges and services both on campus and throughout the community. Beneficiaries enjoy discounts at local food and retail businesses as well as exclusive access to the Student Activities computer lab and game center. Additionally, portions of the proceeds obtained from the purchase of these stickers are used to enrich the college's academic, athletic and artistic community by helping to fund extracurricular programs and events. The sticker may be purchased online via WebStar during registration or at the Admissions and Records office throughout the semester. For further information on the Associated Benefits Sticker, visit the Student Activities Center, or call (714) 484-7198.

CAMPUS ID CARD

– *Enrich your college experience!* –

The Campus ID card is an invaluable tool which not only identifies Cypress College students, but also grants them access to a wide array of services and programs. A smart addition to any wallet, the card is required at the library, bookstore and gym as well as the various computer/learning labs located throughout the college. In addition, a student may be required to present their ID when using support services such as Financial Aid, Admissions and Records, Bursars, the Transfer Center. The card may be purchased online via WebStar during registration or at the Admissions and Records office throughout the semester. Please note: the \$2.50 fee must be paid every semester. This fee supplies a validation sticker and entitles the student to a new ID card. If the student wishes to keep their current card, the new sticker can simply be placed over the old. For further information on the Campus ID Card, visit the Student Activities Center, or call (714) 484-7198.

ENROLLMENT FEES

All students, residents and non-residents must pay the enrollment fee of \$46.00 per unit (\$23.00 per .5 unit). The enrollment fee may vary should the state legislature take action to change it.

HEALTH FEE

Pursuant to health code and district policy, Cypress College has a mandatory health fee. The health fee is \$16.00 per semester (\$13.00 for the Summer Intersession) for each student regardless of the number of units taken.

Any student who depends exclusively on prayer for healing in accordance with the teachings of a bona-fide religious sect, denomination or organization, provided that the student presents documentary evidence of an affiliation of such bona-fide religious sect, denomination or organization, shall be exempt from paying such a fee. Additionally, students attending Cypress College exclusively under an approved apprenticeship training program are exempt from paying the health fee. The health fee will be refunded to any student who withdraws from all courses prior to the 10% date of the length of the course. All Special Admit students are required to pay the health fee each term they attend.

NON-RESIDENT TUITION

Non-residents of the state of California are charged tuition at \$202 per unit (includes \$23.00 per unit capital outlay fee as provided in Education Code Section 76141). Non-resident tuition is in addition to the enrollment fee paid by all students. If you believe you should be reclassified as a resident student, it is your responsibility to request reclassification at the Admissions and Records Office prior to registering.

PARKING

Students who choose to use the campus parking lots are required to pay a parking fee, the amount of which is determined each year on the basis of parking needs. The parking permit authorizes students to use any of the six parking lots open to student parking and designated student parking on Circle Drive, designated student parking at Fullerton College as well as designated student parking at our Anaheim Campus. The parking hanger does not guarantee a parking space, but will permit parking in designated spaces at both colleges. Revenue from parking fees is used exclusively to offset costs of campus parking.

REFUNDS

Enrollment fees, non-resident tuition fees, health fees and material fees are fully refundable if withdrawal from classes is processed on or before the end of the second week of classes. (See current semester schedule for exact dates.) Refunds must be requested during the semester of attendance. After the second week, there will be no refunds for withdrawal. The same fees for Short Term classes are refundable if the student withdraws from class by the 10% date of the length of the course.

REFUND PROCESSING FEE

A refund processing fee of \$10.00 per semester will be deducted from the enrollment fee refunds. The fee will be waived for students who are administratively dropped from class(es) due to cancellation of class(es), student disqualification or course repetition.

SERVICE CHARGE

There is a \$25.00 service charge on all checks returned by your bank, and your enrollment at the College, as well as your credit, may be affected.

Cypress College participates in the COTOP program (Chancellor's Office Tax Offset Program) and will be charging the administrative fee if your account is sent to COTOP for collection. To avoid these additional charges, please pay all debts owed to the college in a timely manner. This includes registration fees, checks returned by your bank, and any other fees due on your student account.

STUDENT REPRESENTATION FEE

All students are urged to pay this \$1.00 fee. This fee will be used so that students may represent students' views and positions at city, county, and district governments as well as state legislative offices and other governmental agencies.

TRANSCRIPT FEES

The first two copies of the student transcript are free and a \$3.00 fee per transcript is levied thereafter. (NOTE: The \$3.00 fee is subject to change at any time.)

VERIFICATION OF ENROLLMENT/STUDENT STATUS

Beginning Fall 2006, Cypress College partnered with the National Student Clearinghouse (NSC) to provide degree and enrollment verifications on behalf of past and present Cypress College students. This self-service is free and adheres to the privacy mandates of the Family Education Rights and Privacy Act (FERPA) of 1974.

It is conveniently accessible 24 hours a day, 7 days a week by logging into myGateway. Enrollment verifications are available ten business days after the beginning of a term.

Third party verifications can be obtained through www.studentclearinghouse.org for a fee of \$3.00. In rare cases when a verification form must be completed by the Admissions and Records Office, a fee of \$3.00 per request will be charged. Rush requests are an additional \$10.00 and photo ID is required for service.

Students are advised to visit the Financial Aid Office for the processing of loan forms.

Academic Policies

Academic Freedom

(This represents Board Policy AP4030, adopted 2/12/08)

The Association of American Colleges and the American Association of University Professors have long recognized that membership in the academic profession carries with it special responsibilities. The protections provided under this section are correlative with certain duties. Academic freedom must be balanced with the obligation of the District to protect the right of students to learn in an environment characterized by civility, open inquiry, and rigorous attention to the search for the truth, free of unlawful discrimination.

It is recognized that an essential function of education is a probing of opinions and an exploration of ideas that may cause some students discomfort. The District affirms the use of a variety of teaching methodologies to fulfill its obligation to raise difficult and meaningful questions in the educational development of students in curricular and co-curricular settings. Faculty members are entitled to freely discuss issues germane to their subject matter as measured by professional standards set by the community of scholars. This freedom involves the right to introduce controversial topics, as long as the manner of presentation involves objective reasoning and rational discussion.

There shall be no curtailment of faculty presentation of factual or theoretical material relating to all points of view.

Faculty are citizens, members of a learned profession, and officers of an educational institution. When they speak or write as citizens, they should be free from institutional censorship or discipline. However, when doing so, they should apply the best standards of their professions and make every effort to indicate they are not speaking for the institution.

The District will consult with discipline faculty chosen by the Academic/Faculty Senate with respect to contemporary practices and professional standards for course content and delivery when evaluating issues of academic freedom.

Academic Honesty

Students are expected to abide by ethical standards in preparing and presenting material which demonstrates their level of knowledge and which is used to determine grades. Such standards are founded on basic concepts of integrity and honesty. These include, but are not limited to the following areas:

1) Students shall not plagiarize, which is defined as stealing or passing off as one's own ideas or words of another and as using a creative production without crediting the source. The following cases are examples of what constitutes plagiarism:

- paraphrasing published material without acknowledging the source.
 - making significant use of an idea or a particular arrangement of ideas, e.g., outlines.
 - writing a paper after consulting with persons who provide suitable ideas and incorporating these ideas into the paper without acknowledging the debt.
 - submitting under one's own name, term papers or other reports which have been prepared by others.
- 2) Students shall not cheat, which is defined as using notes, aids, or the help of other students on tests or exams in ways other than those expressly permitted by the instructor; and as misreporting or altering the data in laboratory or research projects involving the collection of data.
- 3) Students shall not submit an original paper or project to more than one class without approval from the second instructor. Instructors who do not accept previously submitted papers should so inform the students in the course syllabus.

- 4) Students shall not furnish materials or information in order to enable another student to plagiarize or cheat.

Plagiarism Prevention and Detection: In its commitment to academic honesty, Cypress College uses Turnitin.com software to prevent and detect plagiarism.

The instructor reserves the right to submit student assignments to Turnitin.com to check for textual similarities between those assignments, Internet sources and the Turnitin.com assignment database. Students will be required to electronically submit their written work for plagiarism checking. Assignments submitted to Turnitin.com will become part of their database and will be used only for plagiarism prevention and detection.

Students agree that by enrolling in a course, assignments may be subject to the above plagiarism prevention and detection processes.

An instructor who has evidence that an act of academic dishonesty has occurred, after speaking with the student, is obligated to take the following steps:

- 1) Assign an appropriate academic penalty such as an oral reprimand (as in cases where there is reasonable doubt that the student knew that the action violated the standards of honesty); or assign an "F" on all or part of a particular paper, project, or exam (for example, where there was proof that it was a one-time occurrence). In cases where an "F" was assigned, report the incident to all appropriate personnel. (See Step 3.)
- 2) In cases where the dishonesty was serious, premeditated, or part of an ongoing scheme, request an ad hoc review board made up of at least three faculty from the department or division of the instructor involved. This review board is to be appointed by the Academic Senate President or his/her delegate in consultation with the department coordinator, or if none is in place, with the members of the department. Supply to the review board the documents which are suspect and any other documents completed by the student which might help determine if academic dishonesty occurred. It would then be the responsibility of the review board to determine academic penalties as appropriate.
- 3) Report to the student involved, to the department coordinator, to the Division Dean, and to the Dean of Counseling and Student Development, the alleged incident of academic dishonesty, including relevant documentation, and recommendations for action that he or she deems appropriate.
- 4) The appropriate Division Dean shall maintain an academic dishonesty file of all cases of academic dishonesty with the appropriate documentation.
- 5) Students shall be informed when their names are inserted into the file and provided with copies of any appeals or disciplinary procedures in which they may become involved. The appropriate Division Dean may initiate disciplinary proceedings under Education Code, Article 3, Section 76030–76037; when two or more incidents involving the same student occur, he/she shall do so.
- 6) Students charged with violations resulting in disciplinary action have the right to appeal the findings to the Petitions Committee under the Rules and Procedures of Due Process.

Academic Honors

HONORS AT ENTRANCE

High school graduates entering Cypress College as first time college students may qualify for “Honors at Entrance” by having earned a 3.5 GPA in high school with physical education grades excluded. The High School transcript must be on file in the Admissions and Records Office. This achievement will be indicated on the college transcript. Application for Honors at Entrance should be made in the Admissions and Records Office during the student’s first semester of attendance.

Semester Honors

DEAN’S LIST

Those students who officially **complete** (as shown on their transcript) 12 or more units in letter grade courses in a semester and earn a grade point average between 3.0 and 3.74 are placed on the Dean’s List for the semester.

PRESIDENT’S LIST

Those students who officially **complete** (as shown on their transcript) 12 or more units in letter grade courses in a semester and earn a grade point average of 3.75 or above are placed on the President’s List for the semester.

HONORS AT GRADUATION

In recognition of academic excellence for completion of the associate degree, students are awarded graduation honors as follows:

Honors	3.30–3.74
High Honors	3.75–4.00

Graduation honors are calculated using all degree applicable work completed. This includes coursework completed at Fullerton College and all other accredited institutions for which an official transcript has been received.

Graduation honors will be indicated in the commencement program and on the student’s diploma and transcript. However, for candidates (those students with final grades pending), the commencement program will note “candidate” as their degrees and honors have not yet been confirmed. When final grades are posted, a recalculation of grades will be completed and, if the student qualifies, the graduation honor will be noted on the diploma and transcript.

Academic Renewal Policy

Under certain circumstances students may elect to have previously completed courses that resulted in substandard grades disregarded in the computation of their grade point average (GPA). To reduce the negative impact of past academic failure, Cypress College supports Academic Renewal defined in accordance with Section 55046, Title 5, California Code of Regulations. Courses used in awarding an associate degree, certificate or transfer certification will not be alleviated.

- Only units taken at Cypress College may be disregarded. No more than twenty-four units of substandard grades (D, F, NC, and NP) may be disregarded.
- A minimum of twelve months must have elapsed since the most recent coursework to be disregarded was recorded.

- A minimum of twelve units must be completed at Cypress College or any other accredited college or university with a grade point average of 2.5 in all units since the last substandard grade to be disregarded.
- Courses that meet the present educational goals of the student and that are appropriate for repetition may be exempt for consideration for alleviation.
- The college may disregard particular previously recorded substandard work in the computation of a student’s cumulative grade point average according to the Academic Renewal procedures.
- A student may be granted Academic Renewal only once and is irreversible once posted to the transcript. The substandard grade(s) alleviated will be subtracted from the grade point average; however, they will remain legible on the transcript and annotated to indicate Academic Renewal.
- Academic Renewal by Cypress College does not guarantee that other institutions outside the District will approve such action. This determination will be made by the respective transfer institution.

Students must file an Academic Renewal petition form with the Admissions and Records Office. The form is available in the Admissions and Records Office. If other college course work will be used to qualify for Academic Renewal, current and official transcripts from all accredited colleges must accompany the petition or be on file in the Admissions and Records Office at the time the petition is submitted.

Advanced Placement Credit

Please refer to External Exam Credit Area of this catalog.

Attendance

Regular attendance is expected of every student. Attendance at the first class meeting is especially important since a full period of instruction begins the first day of the class. Any student not attending the first class meeting may be dropped by the instructor.

In the case where a class is taught entirely online, instructors may drop students who have not been in contact with the instructor by the end of the first day of classes for that semester or short-term session.

ABSENCES

Absences are handled as follows:

- After a student accumulates in any class more than a week’s absences (more than the number of times the class meets per week), consecutive or nonconsecutive, an instructor may drop the student according to the drop deadline dates.
- Absences in a Distance Education course are accounted for by monitoring academic attendance or attendance at an academically-related activity. A student will be considered to be “present” in a course if there is evidence of weekly participation in an academically-related activity including, but not limited to, physically attending in-person sessions of a hybrid course, submitting an academic assignment, taking an exam, substantively participating in a course online discussion, study group, or other synchronous or asynchronous activity, or by initiating contact with the instructor in matters related to the course. It is the responsibility of the instructor to define grounds for dismissal in the Distance Education course syllabus.

- A student will be considered “absent” if there is no evidence of participation in an academically-related activity for the course for more than one week or if the student accumulates a consecutive or non-consecutive lack of academically-related activities of more than a week that is more than the number of times the class meets per week. For example, in a three-unit online class that would typically meet on campus three hours a week, one week’s worth of missed academically-related assignment(s) or activity(ies) could be grounds for dismissal. A student who has not submitted assignments or participated in an academically-related activity for one week may be dropped from the course.
- A student who must miss one or more classes because of a field trip or other authorized activity, such as athletics or music groups, will be issued an *Authorized Absence Excuse* (available in each division office) by the instructor under whose supervision the activity will occur. The student shall have this excuse signed by the instructors of the classes that will be missed **before the absence occurs**. It is recommended that these transactions be carried out at least two days before the activity. The signed excuse must be presented to the instructor in charge of the activity, who shall in turn file it with the Admissions and Records Office upon the conclusion of the activity.
- No absence excuses a student from making up class work missed. Students should realize that undue absences may adversely affect their grades.
- In the event a student is absent for a prolonged period of time it is expected that contact will be made with the respective instructors immediately to advise the instructor of this absence and the reasons for it. The instructor may then decide whether or not the student may continue in the class or withdraw. It should be noted that failure to make this contact and follow through with the decisions made at this time could result in the student receiving a grade of “F” or “NP” in the class.

STUDENT RESPONSIBILITY

While an instructor may drop a student who has poor attendance, **it is the student’s responsibility to officially drop the class through myGateway**. Failure to officially withdraw within the published deadlines may result in the assignment of a substandard grade. Refer to the Class Schedule for further instructions on “How to Add/Drop a Class.”

Auditing

Auditing is available for students who have successfully completed a class for credit the maximum times allowed at Cypress College. Enrolled students who wish to audit a class must file a petition with the Admissions and Records Office. **The petition is available at the Admissions and Records Office.**

The petition must be submitted during the second week of the class. Upon consultation with the instructor and the dean of the division involved, the Admissions and Records Office will review the petition for approval or denial. Once the request has been approved, students will not be permitted to change from an audit to a credit status. Auditing a class does not result in a grade posted to the student’s transcript. For required fees and additional information, contact the Admissions and Records Office.

Catalog Rights

Cypress College issues a new catalog each year. The information published in the catalog is in effect for the academic year beginning with the Fall semester and concluding with the Summer session.

The courses required for a specific degree or certificate, or general education may change from one catalog to the next and, therefore, may change during the period of time that a student attends the college. Catalog rights, established when a student first takes classes at the college, protect the student from being held for additional requirements that may be added to a later catalog.

For the purposes of meeting graduation or certificate requirements, students may elect to meet the requirement of either

- (1) The catalog that was in effect at the time they began taking courses at Cypress College, or
- (2) Any catalog that is or has been in effect during the time that they have maintained continuous enrollment before graduation, or
- (3) The catalog that is in effect at the time they file an application for a degree or certificate.

Students maintain catalog rights by maintaining **continuous enrollment** at Cypress College — that is, by receiving a grade of “A,” “B,” “C,” “D,” “F,” “CR,” “P,” “NC,” “NP,” “RD,” “W,” or “I” on their transcripts for at least one course per academic year. Documented military or medical leave or attendance at another regionally accredited institution of higher learning will not be considered an interruption of enrollment. This policy supersedes all previous catalog rights provisions and applies only to programs at Cypress College.

The academic year is considered Fall and Spring and does not include the Summer term for continuous enrollment purposes.

Challenging Prerequisites, Corequisites, or Other Limitations on Enrollment

GROUNDS FOR CHALLENGE

Where a student is denied enrollment in a program or course on the grounds that the student does not meet a prerequisite or corequisite, or on the basis of other limitations on enrollment, the student may challenge such prerequisite, corequisite or limitation on one or more of the following grounds:

1. The prerequisite, corequisite or other limitation on enrollment has not been established in accordance with the district’s process for establishing prerequisites, corequisites, and other limitations on enrollment.
2. The prerequisite, corequisite or other limitation on enrollment is either unlawfully discriminatory or is being applied in an unlawfully discriminatory manner.
3. The basis upon which the district has established an enrollment limitation does not in fact exist.
4. The student has the knowledge or ability to succeed in the course or program despite not meeting the prerequisite or corequisite.
5. The student will be subject to undue delay in attaining the goal of his or her educational plan because the prerequisite or corequisite course has not been made reasonably available by the college.

BURDEN OF PROOF

The student shall bear the burden of proof in demonstrating that grounds exist for the challenge.

1. In the case of a challenge under Grounds for Challenge number 4, the student shall provide evidence of knowledge and/or skills, by virtue of placement/assessment testing, academic coursework, independent learning, experience, or a combination of these which are at least equivalent to the knowledge and/or skills the student would have possessed had he or she successfully completed the prerequisite or corequisite.
2. In the case of a challenge under Grounds for Challenge number 5, the student shall provide evidence that the student has declared a broad educational intent or specific educational goal and has developed a Student Educational Plan in conformity with the provisions of Section 55530(d) of Subchapter 6 of Chapter 6 of Division 6 of Title 5 of the California Code of Regulations.

CHALLENGE PROCEDURE

Filing of Challenge:

1. A challenge with respect to any prerequisite, corequisite or limitation on enrollment initiated pursuant to this policy shall be made upon the appropriate challenge form, which may be obtained from the Matriculation or the Office of Instruction.
2. The completed challenge form must be filed with the Office of Instruction in accordance with the following deadlines:
 - a. for the Fall term, not earlier than Friday of the fifteenth week of the Spring semester and not later than the first day of instruction for the Fall semester;
 - b. for the Spring term, not earlier than Friday of the twelfth week of the Fall semester and not later than the first day of instruction for the Spring Semester.
 - c. for the Summer intersession, not earlier than the first Monday in May and not later than the first day of final examinations for the Spring semester.
3. In the case of a challenge under Grounds for Challenge number 4, the completed challenge form must be accompanied by appropriate evidence of skill or accomplishment such as placement/assessment results, transcripts from an accredited institution or appropriate foreign institution, work-related experience, or other evidence of relevant experience. To warrant consideration, any such evidence shall be of a clear and reliable nature.

Change of Name or Address

Students who wish to change their name on official college records must submit the Change of Name form with the Admissions and Records Office. Proof of a legal name change and picture identification will be required to complete the process. It is recommended that a new student ID card be obtained. The fee for a new card is \$2.50. Mailing and email addresses can be updated by accessing the "Personal Information" channel on myGateway.

Class Cancellations

Cypress College reserves the right to cancel any class for which enrollment is not sufficient to warrant continuation, and to change the class hours and/or days as necessity demands.

Class Transfers

A student may change from one section to another of an identical course with the same or different instructors providing the instructors approve. The change may take place at the same or different level in the same subject area at any time during and up through the 14th week for semester length classes, provided both instructors approve. The class must be of like duration, i.e., exactly the same length. Consult the Admissions and Records Office for information on the required class transfer process and deadlines for classes that meet less than the full length of the semester.

CLEP Examination Credit

Please refer to External Exam Credit Area of this catalog.

Computing Resources Acceptable Use Policy

PURPOSE: The purpose of this document is to explain the terms of use for instructional computing resources available to students of Cypress College. All computing resources are intended to support the research and educational mission of Cypress College; their use is a privilege and a responsibility. The use of computing resources is subject to all applicable local, state and federal laws, the general guidelines outlined in this document, and any specific guidelines in effect at individual campus computing centers. The district "Acceptable Use/Computer and Electronic Communication Systems" policy can be found at http://www.nocccd.edu/Policies/PDFs/3720.BP.final_032904.pdf and http://www.nocccd.edu/Policies/PDFs/3720.AP.final_032904.pdf.

DEFINITION: As used in this document, computing resources include (but are not limited to): Enterprise server terminals, personal computers, local area networks (LANs), wide area networks (WANs), wireless printers, CD-ROM drives, cables, connections, software applications such as word processing, database and spreadsheet programs, library catalogs, full-text databases, telecommunications packages, all Internet resources and services, and all other computer equipment and software.

CAMPUS COMPUTING CENTERS: Individual computing centers maintain their own specific policies regarding the use of their resources. Users of individual computing centers are to follow these policies. Computing centers are authorized to enforce both the campus Acceptable Use Policy and their own individual policies. Users who establish individual computer accounts for use of Internet email or other applications will be required to sign an agreement to abide by the policies of the computing center issuing those accounts.

ENFORCEMENT: *The Acceptable Use Policy is intended to establish and declare the personal responsibility of every individual who uses any computing resource at Cypress College.* By making this policy public and available to all users of computing resources on the campus, Cypress College and its designated representatives reserve the right to deny any or all computing privileges from any individual who refuses to follow the guidelines for responsible computing use. Cypress College also reserves the right to limit, restrict, or deny access to any and all computing resources as the individual situation may require.

GENERAL GUIDELINES: The following guidelines are to be followed by every individual who makes use of computing resources at Cypress College:

The use of computing resources and any resources accessed by them is for the instructional purposes of Cypress College. Individual computing centers reserve the right to restrict activities such as personal email or games when instructional needs require the computing resources.

No tampering with the computing resources. This includes but is not limited to: connecting or disconnecting computer equipment, unauthorized loading of software on a computer, or otherwise altering the set-up of any computer or network of computers in any way.

No illegal use of computing resources. This includes but is not limited to: loading virus programs onto or from any computer system, using the Internet or other telecommunications-based resources to transfer illegal materials or unauthorized versions of copyrighted material, using the Internet to harass, terrorize, blackmail, defraud, or otherwise abuse another person, or using any computing resource in such a manner that it constitutes the breaking of a District or campus policy, or a local, state or federal law.

No use of computing resources for financial or political gain. This includes but is not limited to: sending “chain letters” or other unauthorized and illegal correspondence, advertising, marketing or selling of products, and campaigning for any political cause or individual.

No violation of other individuals’ privacy or rights. This includes but is not limited to: accessing another person’s account or any data stored and used by that person, sharing another person’s private correspondence with others, destroying or modifying data that belongs to someone else, or sending offensive messages of any kind.

Observe all regulations and rules of the individual computing centers. This includes but is not limited to: observing hours of operation, maintaining a reasonable level of quiet in order for others to work, and following all that center’s policies regarding food and beverage use, time limits, printing and downloading, and any other terms of use.

Failure to follow these guidelines may result in disciplinary action on the part of Cypress College and any of its designated representatives (including individual computing centers). Such action may include: restriction or suspension of computing privileges at any or all individual campus computing centers, suspension of other campus privileges, including registration and enrollment, and notification of law enforcement officials.

Continuous Enrollment

See Catalog Rights.

Corrections to Student Information

Admissions and Records requires documentation, such as a marriage license, court order or naturalization papers, for verifying a legal name change. Documentation to prove residency or correct a date of birth or social security number must also be submitted to the Admissions and Records Office.

Mailing and email addresses and phone numbers can be updated through myGateway.

Course Double Counting

Students can double count courses but not units of credit to meet major and general education requirements for graduation.

Course Numbering

Courses completed at Cypress College will transfer to other community colleges. Courses numbered 001 C–099 C are remedial, occupational and/or technical and designed in content and organization for students who do not intend to transfer for the Bachelor’s degree. Courses numbered from 100 C–299 C (including Honors courses) have been certified by Cypress College as being of baccalaureate level for the current school year and as such are transferable to any campus of the California State University system. The transfer institution, however, will determine the extent to which a course satisfies the requirements of a particular degree program. Credit not otherwise applied shall be acceptable as general electives to the extent that the particular degree objective permits. Students who plan to transfer to any campus of the University of California or other university or college should check with a counselor for transferable courses since some universities do not accept all courses numbered 100 C–299 C.

Course Progression

Students are expected to take courses on an accepted progressive basis. Students will not receive credit for classes which are considered lower in degree of advancement than those already taken.

Course Repeat Adjustment

In the case of a legally repeated course in which a student initially received a “D” or “F” grade at Cypress College, the original grade will be excluded from the grade point average upon request by the student. Exclusion of a substandard grade is not automatic if the course is repeated and a better grade is received. If the student opts to repeat the course a second time, the last grade received will be the only grade included in the student’s grade point average. A remaining substandard grade for the same course will not be excluded from the student’s grade point average except by an approved Academic Renewal. The exception to Academic Renewal is if the student has used the remaining substandard grade for the completion of an associate degree, certificate or transfer certification.

A course repeat adjustment card can be obtained in the Admissions and Records Office, and must be submitted by the student. If approved, the student’s Cypress College permanent record shall be annotated in such a manner that all course work remains legible; however, Cypress College does not annotate or otherwise alter the permanent records of any other institution.

Course Repetition

- Students may repeat no more than two times the same course in which substandard grades or W’s were assigned at Cypress and Fullerton Colleges. Substandard grades are considered to be D, F, NC, or NP.
- The college shall exclude the first two substandard grades a student has earned in a course offered at a college within the District in computing the overall GPA if the student repeats the course two times.

- Students may petition to have a substandard grade, grade points, and units excluded from the computation of the student's grade point average in accord with college procedures.
- An assignment of MW in accord with provisions related to military service shall not count toward the college computation or exclusion related to probation or dismissal.
- An assignment of MW shall not count toward the maximum allowable number of repetitions to which the student would otherwise be entitled.
- Students who have previously earned a grade of C or better in a course offered at the colleges within the District shall be allowed to repeat the course under certain conditions.
- In accord with a determination that such repetition is required as a disability-related accommodation for a particular student, repetition in a special class for students with disabilities shall be allowed.
- When course repetition occurs, the permanent academic record shall be annotated in such a manner that all work remains legible, insuring a true and complete academic history. (NOCCCD BP4225 — effective March 8, 2011)

Credit by Examination

The basic purpose of Credit by Examination is to allow unit credit for prior or advanced knowledge of class material by the student. Currently enrolled students in good standing may request Credit by Examination (also known as “challenging” a course) in a subject matter field in which they are especially qualified through previous training or experience if credit or advanced placement has not previously been given in that field. Examinations will be sufficiently comprehensive to determine that the student has essentially the same knowledge and skills as a student who successfully completes the course.

It is hoped that students will take advantage of this opportunity in order to enroll in more advanced courses in the subjects challenged. *Credit by Examination* is not intended to replace make-up examinations for courses not completed and/or courses taken in high school. The student should contact the Dean of the appropriate division prior to the ninth week of the semester to initiate the process with a Credit by Examination petition. Students may take the Examination if their petition is approved.

Credit by Examination and Proficiency Examinations may be taken only by students enrolled in the College. Only one challenge is allowed for each course, and a **maximum of 12 units** will be granted via Credit by Examination.

- Completed petitions will be received until the seventh week of each semester. Examinations will normally be administered during the 12th and 13th weeks only. Specific arrangements as to day and hour are to be made with the instructor.
- Criteria for petition approval will be determined by the appropriate division. General guidelines will include evidence of previous learning experience, evidence to indicate probable success in the examination, and future enrollment plans.
- Appeals upon denial of a student's petition will be brought to the Petitions Committee at the student's request.
- The Academic Divisions will determine which courses are eligible for challenge. Examination content and grade standards will also be determined by division faculty.

In instructor-administered examinations, results will be announced within two weeks after the examination week. Exams are graded on a *Pass/No Pass* basis. The student may choose whether or not to have passing results recorded on his or her permanent record. If the student chooses to have the results recorded, the Pass (P) grade and the unit value will appear with a notation indicating the credit was obtained by Credit by Examination.

Some of the courses challenged by examination may be taken for a letter grade. These will not count toward the twelve residency units required by Cypress College to earn an associate degree. For courses which may be taken for a letter grade, students who plan to transfer to a four-year institution should **not** choose the *Pass/No Pass* grading option. Many transfer institutions will not accept *Credit/No Credit* or *Pass/No Pass* graded courses to be applied toward major, minor and general education requirements. Students should check the catalog of the transfer institution and see their counselor for further information. There is a current rate per unit fee for taking the challenge examination.

The following courses may be challenged by examination:

ATC 191 C Airline Reservations: APOLLO	Health Science Courses See Division Dean
AVIA 190 C Flight Training — Private Pilot	MATH 130 C Survey of Calculus
AVIA 191 C Flight Training — Instrument Rating	MATH 150AC Calculus and Analytic Geometry
AVIA 192 C Flight Training — Commercial Pilot	MATH 150BC Calculus and Analytic Geometry
AVIA 193 C Flight Training — Flight Instructor	MATH 250AC Intermediate Calculus
AVIA 196 C Ground Trainer Laboratory — Instrument Flight	MATH 250BC Intermediate Calculus
AVIA 232 C Instrument Rating (for first credit only)	Mortuary Science Courses See Department Program Director
Dental Assistant Courses See Dept. Program Director	Nursing Courses See Department Program Director
Dental Hygiene Courses See Dept. Program Director	PE 234 C Contemporary Personal Health
Health Info Tech Courses See Dept. Program Director	Psychiatric Tech Courses See Department Program Director
	Radiologic Tech Courses See Department Program Director

Examinations

Class instruction includes frequent examinations throughout the semester so that students can judge their progress. The final examination is a requirement for each course and will be given on the last day of the class. All students must take these examinations at the scheduled time and place. Any exceptions to the above policy will be made only after consultation with the Division Dean.

External Exam Credit

Advanced Placement (AP), College Level Exam Program (CLEP), International Baccalaureate (IB)

A passing score on an AP exam, CLEP exam, or IB exam may allow a student to receive subject credit for various requirements. The college utilizes external exam scores for placing students in appropriate coursework in some cases as well as waiving students from specified occupational degree and/or certificate major coursework or college graduation requirements. Please see a counselor for more information. Students may reference specific course waiver information for Cypress College majors and graduation requirements at <http://www.CypressCollege.edu/services/transfer/articulation.aspx>. Information regarding which subjects can receive local external exam (AP, CLEP, IB) credit can also be obtained from A&R and Counseling Offices.

Attention Students: You should not take classes for which you have earned external exam credit unless a specific university requires a higher score and/or your university major requires it. Duplicative credit will not be awarded by the college or transfer university. Talk to your counselor if you are uncertain whether or not your university major requires a course that you have already received AP, CLEP, or IB credit to determine if you have earned the appropriate score, or need to take the course. Students must file a petition in the Office of Admissions and Records (A&R) to have external exam credit reflected on the college transcript. **It is strongly recommended that students discuss the applicability of external exam credit with a Cypress College counselor before submitting the Petition form to A&R.** The petition form may be obtained from the A&R Office or via link to downloadable forms on the college website: <http://www.CypressCollege.edu/admissions/admissionsAndRecords/downloadableForms.aspx>. In order for the external exam credit to be applied via petition, the official AP, CLEP, or IB scores must be on file in the A&R Office or submitted at the time of application. Students must have the College Board send exam results to A&R (or hand carried copies are also accepted as long as they are in a sealed envelope).

External exam credit (AP, CLEP, IB) awarded for transfer admission and major requirements is determined by the CSU and UC.

The UC policy for external exam credit as it applies toward a student's major is located in the *Quick Reference for Counselors* guide, available for reference in Counseling Offices, the Transfer Center and is also online at <http://www.universityofcalifornia.edu/admissions/counselors/>.

Individual CSU campuses' admissions websites list the external exam credit for major-specific requirements.

Students may earn credit for AP, CLEP, or IB exams to satisfy **IGETC (for CSU or UC transfer), CSU GE and A.A. general education (GE)**. Information on scores that are accepted for the different exams toward specific categories of these general education patterns and the number of units awarded for each category is listed in the policy section of the catalog under that program, i.e. AP, CLEP, IB. **NOTE:** Course credit and units granted by Cypress College for general education may differ from course credit and units granted by a transfer institution toward a student's admission or transfer major program requirements. Please see above information for an individual transfer institution's external exam policy for admission or major.

AP (Advanced Placement) Scores Applied to General Education

A student earning a score of 3 or higher on an AP exam meets the following general education (GE) areas. The Cypress College transcript will show the AP exam credit applicable to the AA/AS G.E. as detailed below. Admissions and Records evaluators will adjust AP exam credit as applicable when a student applies for CSU G.E. Breadth or IGETC certification. Additional information related to the units awarded for specified general education areas as well as units earned toward transfer admissions for CSU and UC are included on the Articulation/Transfer website at: <http://www.CypressCollege.edu/services/transfer/articulation.aspx>. This AP policy information for IGETC is also available at: <http://icas-ca.org/Websites/icasca/Images/IGETC%20Standards%20version%201.3%20final.pdf>. This AP policy information for CSU GE Breadth is also available at: <http://www.calstate.edu/acadaff/codedmemos/AA-2011-12.pdf>. **Note:** *Students should not repeat classes for which they have earned AP credit unless a specific university requires it for their major. AP transfer credit awarded for admission and transfer major requirements is determined by the CSU and UC.

AP Exam	IGETC ¹ Approved Credit (Includes American Institutions)	CSU GE Breadth Approved Credit (Includes American Institutions)	CCC GE Approved Credit
Art History	3A or 3B ²	C1 or C2	C1 or C2
Biology	5B with lab ³	B2 + B3	B1
Calculus AB	2A	B4 ⁴	B2
Calculus BC	2A	B4 ⁴	B2
Calculus BC/AB Subscore	2A	B4 ⁴	N/A
Chemistry	5A with lab ³	B1 + B3	B1
Chinese Language and Culture	3B and 6A	C2	C2
Computer Science A	n/a	n/a ⁴	n/a
Computer Science AB	n/a	n/a ⁴	n/a
Macroeconomics	4B	D2	D
Microeconomics	4B	D2	D
English Language	1A	A2	A1
English Literature	1A or 3B ²	A2 + C2	A1 or C2
Environmental Science	5A with lab ³	B2 + B3 (prior to F'09 only) or B1 + B3	B1
European History	3B or 4F ²	C2 or D6	D
French Language	3B and 6A	C2	C2
French Literature	3B and 6A	C2 (prior to F'09 only)	C2
German Language	3B and 6A	C2 (prior to F'09 only)	C2
Comparative Government and Politics	4H	D8	D
U.S. Government and Politics	4H (and US-2)	D8 and US-2	D
Human Geography	4E	D5	D
Italian Language and Culture	3B and 6A	C2	C2
Japanese Language and Culture	3B and 6A	C2	C2
Latin Literature	3B and 6A	C2 (prior to F'09 only)	C2
Latin: Vergil	3B and 6A	C2	C2
Music Theory	n/a	C1 (prior to F'09 only)	n/a
Physics B	5A with lab ³	B1 + B3 ⁵	B1
Physics C Mechanics	5A with lab ³	B1 + B3 ⁵	B1
Physics C Electricity/Magnetism	5A with lab ³	B1 + B3 ⁵	B1
Psychology	4I	D9	D
Spanish Language	3B and 6A	C2	C2
Spanish Literature	3B and 6A	C2	C2
Statistics	2A	B4	B2
Studio Art	n/a	n/a	n/a
U.S. History	3B or 4F ² (and US-1)	(C2 or D6) and US-1	D
World History	3B or 4F ²	C2 or D6	D

¹ There is no equivalent AP exam for the Area 1B, Critical Thinking/Composition, requirement.

² AP exams may be used in either area regardless of where the certifying CCC's discipline is located.

³ AP exams in Biology, Chemistry, or Physics B earn 4 semester or 5 quarter units toward IGETC certification. For Environmental Science, Physics C: Mechanics and Physics C: Electricity/Magnetism, 3 semester or 4 quarter units are applied for IGETC certification.

⁴ If a student passes more than one AP exam in calculus or computer science, only one examination may be applied toward the CSU baccalaureate degree.

⁵ If a student passes more than one AP exam in physics, only 6 units of credit may be applied to the baccalaureate, and only 4 units of credit may be applied to a certification in GE Breadth.

College Level Examination Program (CLEP) Scores Applied to General Education

A student earning a score of 50 or above on a CLEP exam meets the following general education (GE) areas. The Cypress College transcript will show the CLEP exam credit applicable to the AA/AS G.E. as detailed below. Admissions and Records evaluators will adjust CLEP exam credit as applicable when a student applies for CSU G.E. Breadth or IGETC certification. Additional information related to the units awarded for specified general education areas as well as units earned toward transfer admissions for CSU and UC are included on the Articulation/Transfer website at: <http://www.CypressCollege.edu/services/transfer/articulation.aspx>. This CLEP policy information for CSU GE Breadth is also available at: <http://www.calstate.edu/acadaff/codedmemos/AA-2011-12.pdf>. *CLEP scores may not currently be used for IGETC. **Note:** *Students should not repeat classes for which they have earned CLEP credit unless a specific university requires it for their major.* CLEP transfer credit awarded for admission and transfer major requirements is determined by the CSU.

CLEP Exam	CSU GE Approved Credit (Includes American Institutions)	CCC GE Approved Credit
American Government	D8	D
American Literature	C2	C2
Analyzing and Interpreting Literature	C2	C2
Biology	B2	B1
Calculus	B4	B2
Chemistry	B1	B1
College Algebra	B4	B2
College Algebra — Trigonometry	B4	B2
College Composition	N/A	A1
English Literature	C2	C2
French Level II	C2	C2
German Level II	C2	C2
History, United States I	D6+US-1	D
History, United States II	D6+US-1	D
Human Growth and Development	E	D
Humanities	C2	N/A
Introductory Psychology	D9	D
Introductory Sociology	D0	D
Natural Sciences	B1 or B2	B1
Pre-Calculus	B4	B2
Principles of Macroeconomics	D2	D
Principles of Microeconomics	D2	D
Spanish Level II	C2	C2
Trigonometry	B4	B2
Western Civilization I	C2 or D6	C2 or D
Western Civilization II	D6	C2 or D

International Baccalaureate (IB) Scores Applied to General Education

A student earning a score of 5 or higher on an IB exam meets the following general education (GE) areas. The Cypress College transcript will show the IB exam credit applicable to the AA/AS G.E. as detailed below. Admissions and Records evaluators will adjust IB exam credit as applicable when a student applies for CSU G.E. Breadth or IGETC certification. Additional information related to the units awarded for specified general education areas as well as units earned toward transfer admissions for CSU and UC are included on the Articulation/Transfer website at: <http://www.CypressCollege.edu/services/transfer/articulation.aspx>. This IB policy information for IGETC is also available at: <http://icas-ca.org/Websites/icasca/Images/IGETC%20Standards%20version%201.3%20final.pdf>. This IB policy information for CSU GE Breadth is also available at: <http://www.calstate.edu/acadaff/codedmemos/AA-2011-12.pdf>. **Note:** *Students should not repeat classes for which they have earned IB credit unless a specific university requires it for their major. IB transfer credit awarded for admission and transfer major requirements is determined by the CSU and UC.

IB Exam	IGETC ¹ Approved Credit (Includes American Institutions)	CSU GE Breadth Approved Credit (Includes American Institutions)	CCC GE Approved Credit
Biology HL	5B (without lab)	B2	B1
Chemistry HL	5A (without lab)	B1	B1
Economics HL	4B	D2	D
Geography HL	4E	D5	D
History (any region) HL	3B or 4F	C2 or D6	D
Language A1 (any language, except English) HL	3B and 6A	N/A	C2
Language A2 (any language, except English) HL	3B and 6A	N/A	C2
Language A1 (any language) HL	3B	C2*	C2
Language A2 (any language) HL	3B	C2*	C2
Language B (any language) HL	6A	N/A	C2
Mathematics HL	2A	B4*	B2
Physics HL	5A (without lab)	B1	B1
Psychology HL	4I	D9	D
Theatre HL	3A	C1*	C1

* A score of 4 earns credit for these CSU GE areas.

Grade Change

Any change in a grade given by an instructor shall be subject to California Education Code Section 76224 (a): *When grades are given for any course of instruction taught in a community college district, the grade given to each student shall be the grade determined by the instructor of the course and the determination of the student's grade by the instructor, in the absence of mistake, fraud, bad faith, or incompetency, shall be final.*

Students requesting an appeal related to a grade received from an instructor should follow procedures detailed under *Petitions and Appeals* in this Catalog. Students should be aware that no grade change will be made after five years from the date of the assignment of the grade. When a grade given in error has been corrected, the incorrect grade is expunged from the student's permanent record.

Grade Reports

Students can access grades using myGateway. Grades are generally available on myGateway approximately three weeks after the end of the term. It is recommended that a student ensure that all grades for the most recent term have posted to their permanent record before ordering a transcript.

Grading System

GRADES AND GRADE POINT AVERAGE

Grades are based upon the quality of work completed. The grade point average (GPA) is computed by dividing all GPA hours/units into quality points received. The meaning of each symbol and its value in quality points is as follows:

A — Superior or Excellent (4 grade points): Honor grade indicating excellence earned as a result of consistently superior examination scores, consistently accurate and prompt completion of assignments, ability to deal resourcefully with abstract ideas, superior mastery of pertinent skills, and promise of success in field relating to the subject.

B — Better than Average — Good (3 grade points): Honor grade indicating competence earned as a result of high examination scores, accurate and prompt completion of assignments, ability to deal well with abstract ideas, commendable mastery of pertinent skills, and promise of continued success in sequential courses.

C — Average — Satisfactory (2 grade points): Standard college grade indicating successful performance earned as a result of satisfactory examination scores, generally accurate and prompt completion of assignments, ability to deal with abstract ideas, average mastery of pertinent skills, and sufficient evidence of ability to warrant entering sequential courses.

D — Passing, Less than Satisfactory — (1 grade point): Substandard grade indicating the meeting of minimum requirements only earned as a result of low examination scores, generally inaccurate, incomplete or late assignments, inadequate grasp of abstract ideas, barely acceptable mastery of pertinent skills, or insufficient evidence of ability to make enrollment in sequential courses advisable.

F — Failing — (no grade points): Non-passing grade indicating failure to meet minimum requirements earned as a result of non-passing examination scores, inaccurate, incomplete or late assignments, failure to cope with abstract ideas, inadequate mastery of pertinent skills or repeated absence from class.

I — Incomplete — (no grade points, no units attempted): Incomplete academic work for unforeseeable, emergency and justifiable reasons at the end of the term may result in an "I" symbol being entered in the student's record. The condition for removal of the "I" shall be stated by the instructor in a written record. This record shall contain the conditions for removal of the "I" and the grade assigned in lieu of its removal. This record must be given to the student with a copy on file with the Registrar until the "I" is made up or the time limit has passed. A final grade shall be assigned when the work stipulated has been completed and evaluated, or when the time limit for completing the work has passed. The "I" may be made up no later than one year following the end of the term in which it was assigned. Under unusual circumstances a student may petition for a time extension. An incomplete grade must be changed to a letter grade before it can be repeated.

IP — In progress — (no grade points, no units attempted): If a student making satisfactory progress in an open entry course has not finished a course at the end of a semester, the student shall be given an "IP," which indicates the student is in progress of completing the course. The student must re-enroll in the course if the student wishes to continue working in that course. Failure to do so will result in an assignment of a grade by the instructor in place of the "IP." "IP" shall not be used in calculating grade point averages.

P — Pass — (no grade points, no units attempted, but counts for units completed): Pass means that credit has been earned for the course although there are no grade points and the grade is not used in computing the grade point average, and will reflect performance equivalent to a C or better under the letter grade system.

NP — No Pass — (no grade points, no units, no units completed): No Pass means that neither units nor grade points have been earned. Units for which NP is given are not to be used in calculating grade point averages.

RD — Report Delayed — (no grade points, no units completed): The "RD" symbol may be assigned by the Registrar only. It is to be used when there is a delay in reporting the grade of a student due to circumstances beyond the control of the student. It is a temporary notation to be replaced by a permanent symbol as soon as possible and shall not be used in calculating a grade point average.

W — Withdrawal — (no grade points, no units attempted, no units completed): A "W" grade indicates that the student has withdrawn from college or dropped from a class section prior to the specified drop date. The grade indicates the course has been cancelled from the student's program of study without credit and is not included in the grade point average calculation. (See Withdrawal Policy)

MW — Military Withdrawal — (no grade points, no units attempted, no units completed): A "MW" means the student is a member of an active or reserve United States military service and was forced to withdraw because of military orders. Students shall be permitted to withdraw upon verification of such orders. Students must submit a copy of their orders to the Admissions and Records Office. Military withdrawal shall not be counted in progress probation or dismissal calculations.

Pass/No Pass Grading

The Pass/No Pass (P/NP) grading option was designed to encourage students to explore courses in areas where they feel they have an interest but no special competence. Some of these courses may be taken for a letter grade.

P/NP is not the same as auditing and students who plan to transfer to a four-year institution should **not** choose the Pass/No Pass grading option. Many transfer institutions will not accept Pass/No Pass graded courses to be applied toward major, minor and general education requirements. Check the catalog of the transfer institution and/or see a counselor for further information.

The following policies govern Pass/No Pass grading at Cypress College:

P — Pass will reflect performance equivalent to a C or better under the letter grade system. Pass (P) grades will award units completed.

NP — No Pass will reflect performance not equivalent to a C or better under the letter grade system. NO Pass grades will enter into calculations for progress probation and progress dismissal.

Students may enroll in up to six units in each semester on a Pass/No Pass basis.

A maximum of 12 units of *Pass/No Pass* courses, excluding COUN 140 C and work experience, will be allowed at Cypress College.

All units earned as *Pass/No Pass* shall be disregarded in determining a student's GPA at Cypress College.

The units earned on a *Pass/No Pass* basis shall be counted toward the AA or AS 60-unit requirement. If a course is transferable with a letter grade, it may also be transferable with a credit grade subject to the limitations imposed by the transfer institution. See the catalog of the transfer institution and/or a counselor for further information.

After consulting with a counselor, a Request for Pass/No Pass form must be completed by the student and instructor. The student must submit the white copy of the request form to the Admissions and Records Office by the Friday of the fourth week for a full-semester class and 30% of short term, open entry and summer classes. If the form is not filed by the deadline, the instructor will be required to submit a grade other than Pass/No Pass.

Students may not change grading systems after the submission deadline.

IB (International Baccalaureate) Examination Credit

Please refer to External Exam Credit Area of this catalog.

International Transcript Evaluations

Students who have attended colleges and universities outside of the United States and believe they have successfully completed courses applicable to the Associate Degree or Certificate requirements must have their transcripts evaluated by an approved international evaluation agency before credit can be determined. A list of approved agencies is available in the Counseling, Admissions and Records and International Student Offices. Students who desire credit for ENGL 100 C will need to have their transcripts evaluated, achieve a satisfactory score on the English Assessment test and meet with a counselor.

Non-Degree Credit Courses (Basic Skills)

These courses are intended to help students gain the skills they need to perform in "college level" courses. Therefore, Non-degree credit courses are not applicable toward the Associate Degree. However they **do apply** toward the following categories: Athletic Eligibility, Social Security Benefits, Work Study and Financial Aid, Associated Student Body Office and Full-Time Status.

The following are *Non-Degree Credit* courses:

CHEM 060 C Chemistry Review	ESL 064 C Advanced Oral Skills
CIS 050 C Intro — Comp and Software Concepts	ESL 066 C Advanced ESL Reading
COUN 040 C Academic Success and College Survival	ESL 080 C Low Intermediate ESL 1
COUN 071 C Career Preparation and Life Management	ESL 081 C Low Intermediate ESL 2
COUN 072 C Learning Disabilities Assessment	ESL 082 C Intermediate ESL 1
DMS 060 C Introduction to Sonography	ESL 083 C Intermediate ESL 2
ENGL 027 C Basic Study Skills	HS 030 C Calculations for Medications
ENGL 057 C Reading and Writing I	HS 070 C Health Care Communication
ENGL 058 C Reading and Writing II	MATH 010 C Basic Mathematics
ENGL 060 C College Writing Preparation	MATH 015 C Pre-Algebra
ESL 044 C Beginning Oral Skills	MATH 020 C Elementary Algebra
ESL 051 C Intermediate Pronunciation	MATH 025 C Elementary Algebra Review
ESL 052 C Intermediate ESL Grammar 1	MATH 045 C Intermediate Algebra Review
ESL 053 C Intermediate Grammar 2	NURS 091 C Strategies for Success in Nursing
ESL 054 C Intermediate Oral Skills	PHYS 021 C Problem Solving — Mechanics
ESL 062 C Advanced ESL Grammar 1	PHYS 022 C Problem Solving — Electricity
ESL 063 C Advanced ESL Grammar 2	PHYS 023 C Phys 221 C Problem Solving
	PHYS 024 C Phys 222 C Problem Solving

All other Cypress College courses are degree applicable.

Petitions and Appeals

Petitions for extenuating circumstances and general appeals that relate to policies on admissions, readmission after academic dismissal, graduation, degree and certificate requirements, grades and credit, repetition of courses, academic renewal, withdrawals, etc., should be directed to the Admissions and Records Office. Guidelines and procedures will be made available.

1. **ACADEMIC APPEALS:** Inevitably, with as many interpersonal transactions as occur on a college campus, disagreements with instructors may occur. Should that be the case, a student may take the following procedures:

PROCEDURES

- a. Discuss the matter with the staff member, preferably in private, and try to resolve the issue.
 - b. Consultation with your counselor may also be helpful. If the problem cannot be resolved at that level, the following due process procedures are available to the student.
 - c. Consultation with the Student Advocate at Associated Students may also be helpful. The Student Advocate is an elected member of the Student Government who can help the students to follow the procedures in presenting grievances.
 - d. Students in Vocational programs may need to see the department Coordinator/Director. Programs that deal with patient/client safety and accrediting agencies have additional policies located in their program handbooks/regulations.
 - e. Students who have not been able to resolve classroom problems through an interview with their instructors and the department Coordinator/Director may consult with the Division Dean.
 - f. If the problem is not resolved to the student's satisfaction the student may file an appeal with the Campus Petitions Committee. Petition forms are available from the division deans or from the Office of Instruction.
 - g. A student dissatisfied with the result of his/her appeal to the Campus Petitions Committee may appeal to the College President.
 - h. Student appeals from the College President may go to the District Chancellor.
 - i. Students dissatisfied with their appeal to the District Chancellor may make a final appeal to the District Board of Trustees.
2. **ADMISSIONS AND RECORDS APPEALS:** Appeals regarding College decisions or policies may be made through the Admissions and Records Office. Appeals include matters relating to admissions, a student's records, application or registration deadlines, grades and credit, repetition of courses, academic renewal, tuition and withdrawals, and readmission after dismissal from the college.

PROCEDURES

- a. Obtain the appropriate form from the Admissions and Records Office.
- b. Fill out the form giving all background information regarding the appeal and listing all specific extenuating circumstances. It is often helpful to obtain a written recommendation from a counselor and include that with the petition. If available, attach supporting documents.

- c. Submit the petition to the Admissions and Records Office. Note that the petitioner has certain responsibilities in this process. If an appointment for a personal interview is necessary, the student will be notified.
- d. A decision on the petition will be rendered by the Admissions and Records Office.
- e. Students can contact the Admissions and Records Office to determine the petition results.
- f. A copy of the petition and the written decision will be mailed to the student. The student shall execute the appropriate action as directed.
- g. Appeals of Admissions and Records Office decisions may be made through the Executive Vice President of Educational Programs and Student Services.

Probation and Dismissal Policies

In accordance with state regulations, the following probation and dismissal policies have been established. The primary purpose is to ensure that a student is making satisfactory progress toward an educational objective and to alert the student and the student's counselor to the possible need for additional counseling and/or special services.

PLACEMENT ON SCHOLASTIC PROBATION

Academic Probation — A student who has attempted at least 12 semester units at the college shall be placed on *academic probation* if the student has earned a cumulative grade point average below 2.0 in all units taken at the college.

Progress Probation — A student who has enrolled in a total of at least 12 semester units at the college shall be placed on *progress probation* when the student receives grades of "W," "I," "NC" or "NP" in 50% or more of all units for which the student has enrolled at the college.

The college will make a reasonable effort to notify students who are placed on scholastic probation at the end of each term. Students who are on probation shall be automatically considered conditional registrants, and their programs are subject to adjustment and/or restrictions.

REMOVAL FROM SCHOLASTIC PROBATION

Academic Probation — A student shall be removed from academic probation when the student's cumulative grade point average in all units completed at the college is 2.0 or higher.

Progress Probation — A student shall be removed from progress probation when the percentage of "W," "I," "NC" or "NP" units drops below 50% of all units for which the student has enrolled at the college.

STANDARDS FOR SCHOLASTIC DISMISSAL

Academic Dismissal — A student who has been placed on academic probation shall be subject to dismissal if the student has earned a cumulative grade point average of less than 1.75 in each of two consecutive semesters.

Progress Dismissal — A student who has been placed on progress probation shall be subject to dismissal if the cumulative percentage of units for which entries of "W," "I," "NC" or "NP" reaches or exceeds 50% for two consecutive semesters.

Summer sessions shall be excluded from the consecutive semester criteria.

The college will make a reasonable effort to notify a student who has been scholastically dismissed not later than the beginning of the Fall semester each year. Scholastic dismissal will be noted on the student's academic transcript.

READMISSION AFTER SCHOLASTIC DISMISSAL

A dismissed student may be considered for readmission after filing a petition in the Admissions and Records Office. After the petition is reviewed, the student will be notified by email of an approved or denied decision.

If readmitted:

- Students are considered conditional registrants and their programs are subject to adjustment and/or restrictions.
- Students readmitted after academic dismissal will remain on academic probation until they achieve a cumulative grade point average of 2.0 or higher.
- Students readmitted after progress dismissal will remain on progress probation until the cumulative percentage of "W," "NC," "I" and "NP" grades is less than 50% of all units attempted.
- Failure to maintain the required academic and/or probation criteria to remain enrolled may result in a subsequent dismissal.

Proficiency Examination

READING

Proficiency in reading may be satisfied by ENGL 096 C, ENGL 102 C or ENGL 106 C, by CSU general education certification or IGETC certification or by a satisfactory score on the Cypress College reading proficiency examination.

The *Reading Proficiency Examination* is administered by the Reading Department. No units are given for passing the Reading Proficiency Examination, nor is the total number of units required to complete the Associate Degree lowered. Students who meet the area requirement by the proficiency exam are still required to satisfy the 60-unit requirement for graduation. **Proficiency exams may be taken only once after completion of English 100 C or equivalent.**

This exam will be administered once each semester. Students should contact the Reading Department for dates and times.

MATHEMATICS

A satisfactory score on the Mathematics Proficiency Examination waives the three-unit Mathematics General Education Requirement for the Associate Degree (Category B2). No units are given for passing the Mathematics Proficiency Examination, no units are posted to the student's permanent record, nor is the total number of units required to complete the Associate Degree reduced. Refer to the Mathematics section in the Class Schedule. The Mathematics Proficiency Examination is given only once a semester (usually the sixth week) and can only be taken once (pass or fail). Both a MATH 020 C and a MATH 040 C Proficiency Exam will be administered. Students are advised to check with a counselor to see which test they need in order to meet the graduation requirement.

Remedial Limitation

The State of California has implemented a regulation limiting the number of units students can earn for remedial/pre-collegiate basic skills courses to 30 semester units. In accordance with those guidelines, the North Orange County Community College District has established the following policy (AB 1725 Chapter 973, Statutes of 1988).

PRE-COLLEGIATE BASIC SKILLS COURSES

Pre-Collegiate/basic skills courses are defined as those two or more levels below college-level English and one or more levels below intermediate algebra. The North Orange County Community College District has designated certain courses as remedial/pre-collegiate basic skills courses. These courses include reading, writing, computation, learning skills, and study skills designed to ensure acquisition of those skills necessary for successful completion of associate degree, transfer and occupational courses.

INFORMING STUDENTS

Students shall be informed of the Policy for Remedial Limitation. Courses included will carry an appropriate designation in the *Class Schedule* and the Policy will appear in the *College Catalog*. Students enrolling in these courses will be informed of the limit during the matriculation/orientation process and instructors will be required to include this information in the course syllabus. These courses do count toward financial aid, work-study and athletic eligibility.

PROCEDURES DURING REGISTRATION

A non-exempt student who has completed 20 units in designated remedial/pre-collegiate basic skills courses shall be notified of the regulation limiting the number of remedial units. Information on the waiver and referral process will also be included.

EXEMPTIONS

All remedial courses taken by students enrolled in ESL (English as a Second Language) courses are exempted. Students identified by the District for learning disabled programs are also exempted. When, because of closed enrollment, students are unable to enroll in the next higher level ESL course, they do not lose their exemption status. Students with documented disabilities may petition the Admissions and Records Office for exemption status on a case by case basis.

Students transferring to the North Orange County Community College District from other colleges/universities will begin with a clean slate with regard to the remedial limitation. However, since remediation is totaled within a district, students transferring between Cypress and Fullerton College will carry their remedial units with them. Only those courses taken at a regionally accredited college/university, that are determined to be associate degree level courses or higher, will be applied toward an AA/AS degree within the district.

NOTIFICATION

Upon completion of 30 units in designated basic skills courses, non-exempt students shall be notified that they will be unable to enroll in any additional remedial courses. Information on the waiver and referral process will also be included.

WAIVER

Students who show significant, measurable progress toward the development of skills appropriate to enrollment in college-level courses may petition the Admissions and Records Office for a waiver of the limitation on remedial course work. Students will receive a response, in writing, indicating the granting/denial of the petition. If the petition is granted, students will be informed of the specific period of time or the specific courses approved beyond the 30-unit limit. Students will not be allowed to enroll in courses beyond the 30-unit limitation without a waiver, which will only be granted in extenuating circumstances for students who show significant, measurable progress. The 30-unit maximum enrollment limitation is based on end-of-term units earned with any grade.

ENROLLMENT LIMITATION

Students who do not attain full eligibility status for college-level work within the 30-unit limit will not be permitted to enroll in remedial/pre-collegiate basic skills courses unless a waiver is granted. Students will be referred to adult education non-credit courses per State regulations. The Admissions and Records Office will explain to students their enrollment limitation status at the end of the semester.

REINSTATEMENT

A student may, upon successful completion of appropriate remedial course work or upon demonstration of skills levels, which will reasonably assure success in college-level courses, petition to be reinstated to proceed with college-level course work. The petition is to be filed with the Admissions and Records Office.

SKILL PERFORMANCE AND ACTIVITY COURSES

A student may enroll more than once in an activity, performance or skills course. These courses designated as repeatable are indicated with the statement, "May be taken for credit ___ times." The maximum number of times the class may be taken will be given in that statement. Courses that have a designated skills level (beginning, intermediate, advanced) may be taken for a combined total of four times. Example: a student who has taken beginning voice three times and intermediate voice once has completed the maximum number of repetitions allowed for the course, despite the different skill levels. This policy applies to all activity courses.

Review and Release of Student Information

In accordance with Title V (California Code of Regulations) and the provisions of the Federal Family Educational Rights and Privacy Act (FERPA) of 1974, the North Orange County Community College District has established an official policy for student review of and release of student records and students are guaranteed the right to the privacy of their records. This policy allows for the student to review his or her records after contacting the Admissions and Records Office. The policy also describes when student records will be released to a third party and allows the release of student directory information unless the student informs the Admissions and Records Office that he/she does not want such information released.

This policy is available for student review and includes:

- the types of student records and information maintained;
- the official responsible for the maintenance of each type of record;
- the policies for reviewing and expunging records;
- the right of each student to access of his or her records;

- procedures for challenging the content of student records;
- the cost of producing copies of records;
- the categories of information designated as directory information;
- the locations of any required logs or records;
- definitions of *officials and employees* and *legitimate educational interest* and;
- the right of a student to file a complaint with the United States Department of Health, Education and Welfare.

Any student wishing to review this policy in its entirety may do so by contacting the Admissions and Records Office.

Privacy Release

Pursuant to the Federal Family Educational Rights and Privacy Act (FERPA) of 1974, the North Orange County Community College District has established Board Policy 5040 (BP 5040) — Student Records Privacy, which covers the release of student records. The College may make public, without prior student consent, only certain directory information. This information will consist of the student's name, major field of study, participation in officially recognized activities and sports, weight and height of members of athletic teams, dates of attendance, degrees and awards received, the most recent previous public or private school attended by the student, and any other information authorized in writing by the student.

Students who wish to have this directory information further restricted may do so on the online College Application for Admission or by making the request in the Admissions and Records Office.

No other student information will be disclosed without prior student consent except to college officials and employees of the District with legitimate educational interests unless pursuant to a court order or lawfully issued subpoena, or as otherwise authorized by applicable federal and state laws.

A copy of the District policy is available on the District website, www.nocccd.edu.

Study Load

Most full-time students take 12–14 units. Students must take a minimum of 12 units to be classified as full-time. The maximum load for any student is 19 units, exclusive of work experience and guidance classes. After the first semester of enrollment, a student may, with counselor's approval, carry more units if during the preceding semester he or she earned a grade point average of at least 3.0 in a program of 12 or more units. It may be pertinent for students to consider the following semester unit requirements for particular privileges and activities.

Classification of Students

Students are classified as follows:

Full-time	Enrolled in 12 or more units
Part-time	Enrolled in fewer than 12 units
Freshman	Fewer than 30 units completed
Sophomore	30 or more units completed

Associated Student Office — 6 or more units per semester.

Athletic Eligibility — 12 units per semester, including PE classes.

Financial Aid — Full-Time: 12 units per semester; $\frac{3}{4}$ time: 9 units per semester; $\frac{1}{2}$ time: 6 units per semester.

Social Security Benefits — 12 units per semester.

Veterans Benefits — Full-Time: 12 units per semester; $\frac{3}{4}$ time: 9 units per semester; $\frac{1}{2}$ time 6 units per semester.

Work Study — 12 units per semester required.

The faculty recognizes it is necessary for many students to work while attending college. However, it is expected that students demonstrate good judgment when enrolling under these conditions. Students must make allowance for their employment and other outside obligations in planning their college programs.

In order to maintain a proper academic balance, students should consider the following:

- Students should normally expect to spend at least three hours (one in class and two outside of class) per week for each unit taken.
- Employment and college time together should not exceed 60 hours weekly.
- Students should distribute study time appropriately for each class. Often preparation for a lecture class differs from preparation for a laboratory class.
- Students should take advantage of instructor office hours to consult with faculty as often as necessary.

Transcripts

HIGH SCHOOL TRANSCRIPTS

All matriculated students should have official transcripts sent to the Admissions and Records Office from their high school.

OTHER COLLEGE TRANSCRIPTS

Students with previous college units should have transcripts from all colleges attended sent to the Cypress College Admissions and Records Office. These transcripts can verify completion of prerequisite courses, eliminate the necessity of taking all or part of the placement tests, and can assist the academic counselors when working with the students. Official transcripts from other colleges are required for evaluation of an associate degree, certificate, and meeting general education requirements for transfer.

CYPRESS COLLEGE TRANSCRIPTS

The Admissions and Records Office prepares and permanently retains a record of each student's academic work. The transcript reflects all academic work attempted at Cypress College. It lists chronologically the courses, units, grades, grade points, cumulative grade point average, total units and other relevant academic data.

The normal processing time for transcripts is within 7–10 working days. Forms for requesting transcripts may be downloaded from the college website (www.CypressCollege.edu) and are available in the Admissions and Records Office. Transcript requests may be submitted in person or mailed.

Mail requests must include the student's current and previous names, date of birth, social security number, approximate dates of attendance, number of copies needed, a complete address where the transcript is to be sent, and the student's full signature. Instructions for special handling should be included. Send requests to Cypress College, Admissions and Records/Transcripts, 9200 Valley View St., Cypress CA 90630. Requests with incomplete information may not be processed.

Students are entitled to two (2) copies of their transcripts without cost. Subsequent copies are \$3.00 per copy. (*Note: Fee is subject to change at any time.*) On-Demand transcripts can be obtained for an additional \$10.00.

Transcript requests must include full payment to be processed. Only checks or money orders are accepted and should be made payable to Cypress College. **Cash payments can be made at the Admissions and Records Office but are not recommended to be sent through the mail.** Requests will not be processed if the student has holds or outstanding financial obligations to the college.

Cypress College provides students the capability of sending transcripts electronically to other California colleges and universities. This web-based exchange system is secure and provides instantaneous delivery versus that of postal mail. Access the Main Menu in myGateway/Webstar for more information and the list of the participating institutions that can be sent an electronic transcript.

In accordance with the Family Educational Rights and Privacy Act (FERPA) of 1974 and the provisions established in Board Policy BP 5040 of the North Orange County Community College District records may not be released to a third party without prior written authorization of the student. Contact the Admissions and Records Office for more information. A picture ID of the student and authorized person is required for all transactions.

Withdrawal

It is recognized that, on occasion, students' circumstances might force them to withdraw from a class prior to its completion. **It is the student's responsibility** to initiate withdrawal procedures. Failure to officially withdraw from a class can result in a grade of "F" or "NP" being assigned.

Effective May 2009, many of the processes for course withdrawal related to course repetition have changed for California Community Colleges. In order to comply with the recent revisions of Title 5, students are advised to see an academic counselor prior to withdrawing from a course.

For the purpose of this policy, a “W” indicates that the student has withdrawn from a course without affecting the student’s grade point average. A “W” is given, therefore, under the following conditions and in the manner prescribed below:

SEMESTER COURSES

First Two Weeks of the Semester

Student or instructor may initiate a withdrawal. No notation shall be made on the student’s academic record.

Third Week through Twelfth Week

The student or instructor may initiate a withdrawal. A “W” shall be recorded on the student’s academic record.

Remainder of Course

The student may no longer withdraw from college after the 12th week. The academic record of the student shall reflect a symbol or grade other than “W.” Under extenuating circumstances, a “W” may be granted after the 12th week if the student files a Petition for Exception that is approved by the Office of Admissions and Records.

SHORT TERM COURSES

Until the Day Prior to the First Census

The student or instructor may initiate a drop. No notation shall be made on the student’s academic record. Contact the Admissions and Records Office or see the deadlines printed under the CRN in the class schedule.

From the First Census Through the Withdrawal Date

The student or instructor may initiate a withdrawal up to the time three-fourths of the course has elapsed. A “W” shall be recorded on the student’s academic record. Contact the Admissions and Records Office or see the deadlines printed under the CRN in the class schedule for specific courses.

Remainder of the Course

A student may no longer withdraw from classes after the withdrawal date. The academic record of the student shall reflect a symbol grade other than “W.” Under extenuating circumstances, a “W” may be granted after the withdrawal date if the student files a Petition for Exception that is approved by the Office of Admissions and Records.

Weekend Seminars Until the Day Prior to the First Day of the Seminar

The student or instructor may initiate a withdrawal. No notation shall be made on the student’s academic record.

After the Seminar Begins

The instructor may drop, with a “W,” those students who do not attend the seminar. Those who do attend must receive a symbol or grade other than a “W.” Under extenuating circumstances, a “W” may be granted after the withdrawal date if the student files a Petition for Exception that is approved by the Office of Admissions and Records.

SUMMER INTERSESSION COURSES

First Week

Students are to check with the Admissions and Records Office for appropriate withdrawal dates or see the deadlines printed under the CRN in the class schedule.

Open-Entry Courses

As often as possible, open-entry courses shall be treated according to the regulations for semester courses. Contact the Admissions and Records Office for further information.

Distance Education Program

Distance education is college instruction in which the instructor and student are separated by distance and communicate with the assistance of technology. These courses provide the same quality of Cypress College instruction, teach the same material, are transferable to most four-year baccalaureate institutions, and require the same fees as our traditional in-person classes.

To take a distance education course, students need access to a computer with an Internet connection and have a functioning email address. Distance education students must, at a minimum, be able to:

- Send and receive email with attachments
- Receive private email with attachments (no shared email accounts)
- Use a word processing program
- Save documents
- Navigate and search the Internet
- Install new software applications

Absences in a Distance Education course are accounted for by monitoring academic attendance or attendance at an academically-related activity. A student will be considered to be “present” in a course if there is evidence of weekly participation in an academically-related activity including, but not limited to, physically attending in-person sessions of a hybrid course, submitting an academic assignment, taking an exam, substantively participating in a course online discussion, study group, or other synchronous or asynchronous activity, or by initiating contact with the instructor in matters related to the course.

A student will be considered “absent” when there is no evidence of participation in an academically-related activity for the course for more than one week or if the student accumulates a consecutive or non-consecutive lack of academically-related activities of more than a week that is more than the number of times the class meets per week. For example, in a three-unit online class that would typically meet on campus three hours a week, one week’s worth of missed academically-related assignment(s) or activity(ies) could be grounds for dismissal. A student who has not submitted assignments or participated in an academically-related activity for one week may be dropped from the course. It is the responsibility of the instructor to define grounds for dismissal in the Distance Education course syllabus.

Online Courses

Online courses allow students to attend class and complete the majority of course requirements using a computer connected to the Internet. Some online courses are taught entirely online while others have required in-person meetings for orientations and/or exams. Online students interact with instructors and other students in person or by using a variety of technologies suited for distance education.

Hybrid Courses

Hybrid courses combine online and in-person instruction. Hybrid students meet regularly in-person and online. Meeting dates and times can be found in the current Schedule of Classes.

Course Offerings

The Cypress College Class Schedule includes detailed information regarding the distance education courses being offered each academic term, including prerequisites, fees, or other program requirements.

To enroll in a distance education course, students must follow the standard campus registration procedures for any Cypress College course.

Visit the Distance Education Program website for answers to Frequently Asked Questions (FAQ), specific hardware and software requirements, tips for student's success and more: <http://www.CypressCollege.edu/academics/DistanceEducation>.

Instructional Support Services

Please refer to the Computing Resources Acceptable Use Policy regarding computer centers.

Business and Computer Information Systems Lab

The Business and Computer Information Systems Lab is equipped with computers with a wide range of business application software. The Business and Computer Information Systems Lab (B-202) is available for business students who are concurrently enrolled in courses that require the use of the lab for enhancing and developing business skills. Please refer to the *Class Schedule* for hours of operation.

NORMAL HOURS OF OPERATION:

MON–THU 9:00 am– 9:00 pm

English as a Second Language Program

Cypress College offers special classes in English for students who are non-native speakers of English. The classes are designed to improve reading, writing, listening and speaking skills. Students will have an opportunity to better understand the U.S. culture. They will also learn how to take exams, write essays and do transfer-level college reading and writing assignments. Individualized lab assignments will further build language skills.

Library and Learning Resource Center

Visit our website at www.CypressCollege.edu/lrc

First Floor Instructional Support: Learning Resource Center (LRC)

The **Learning Resource Center Open Lab** offers students computer lab where they may access the Internet, software applications (such as word processing, spreadsheet, and presentation) and course-specific software assigned by their instructors (CD-ROM and online). Also available are flatbed scanners with accompanying photo-editing software. *Students may also use a broad variety of academic support media placed in the LRC by instructors. Some assistance using computers and applications is provided. Electrical power, data and wireless connectivity is also available for students with personal laptop computers.

*Pay for print service for all printing and copies.

NORMAL HOURS OF OPERATION:

MON–THU	8:00 am– 9:00 pm
FRI	8:00 am– 5:00 pm
SAT, SUN AND HOLIDAYS	CLOSED

Individual Tutoring is available in the LRC at no cost to CC students. To schedule an appointment with a tutor, call (714) 484-7183. Normal hours of operation vary depending on tutor availability.

TUTORS ARE AVAILABLE:

MON–THU	9:00 am– 7:00 pm
FRI	10:00 am– 3:00 pm
SAT, SUN AND HOLIDAYS	CLOSED

The English Success Center (ESC) LRC-126

The English Success Center (ESC) provides students with supplemental learning opportunities designed to improve academic reading and writing skills. Staffed by trained tutors as well as Cypress College English, reading, ESL faculty, the ESC offers directed learning activities (DLAs), faculty-led workshops, and informal learning groups. Additionally, students may use ESC computers to write papers for their coursework.

NORMAL HOURS OF OPERATION:

MON–THU	9:00 am– 5:00 pm
FRI	9:00 am– 1:00 pm
SAT, SUN AND HOLIDAYS	CLOSED

Math Learning Center (MLC) Room 127

The MLC provides students assistance in solving problems and in understanding concepts in mathematics, chemistry and physics. Resources include an array of math solutions manuals and computer applications. Students receive assistance from math faculty or peer tutors on a first-come, first-served basis. For more information call (714) 484-7193.

NORMAL HOURS OF OPERATION:

MON–THU	8:00 am– 8:00 pm
FRI	10:00 am– 3:00 pm
SAT, SUN AND HOLIDAYS	CLOSED

Second Floor Instructional Support: Library

Library Website: www.CypressCollege.edu/library

Note: Remote access to the library catalog is available through the website. Remote access to the databases is available to currently enrolled Cypress College students.

The Library maintains a collection of approximately 68,000 books, periodical subscriptions as well as videos, CDs, DVDs, cassette tapes, maps, pamphlets, and several databases with selected full-text newspaper, magazine, and journal articles. Students may access the Internet, the library catalog, databases, the TILT academic research tutorial program, and the extensive full-text EBSCO Host periodical database.

Library Cards: A current student picture ID card is your library card. You must have your student ID card with you in order to check out materials or look at reserve/textbook materials. The textbook collection must be used in the library, but there are books, videos, DVDs, CDs, audio-cassettes, pamphlets and paperback books available for check-out.

Group Study Rooms: Eight group study rooms are available. See staff at the reference desk to make a reservation no more than 7 days and no less than 24 hours in advance. Reservations are made on a first-come, first-serve basis. Dry-erase markers to use in the study rooms are also available.

NORMAL HOURS OF OPERATION:

MON–THU	8:00 am– 9:00 pm
FRI	8:00 am– 1:00 pm
SAT, SUN AND HOLIDAYS	CLOSED

Supplemental Instruction

The Supplemental Instruction (**SI**) Program provides opportunities for students to voluntarily participate in study group sessions for difficult classes. Typically, these sessions are held immediately after the class and therefore, students wishing to utilize this program should keep their schedules free at those times. These study groups are organized and facilitated by **SI** Leaders who are students who have successfully completed the classes in which **SI** is being offered.

Students who participate in **SI** study sessions report increased understanding of concepts and improved study and test-taking skills. Data shows that those students who participate will earn a half to a full grade higher than those who do not participate.

For more information about **SI**, call (714) 484-7323.

Special Programs



Alpha Gamma Sigma Honor Society

Alpha Gamma Sigma (AGS) is the California state wide community college Honor Society which, according to our constitution, has the purpose of fostering, promoting, maintaining, and recognizing scholarship. While being of service to AGS, the college and the community, members will be able to develop civil mindedness and leadership characteristics which will be useful throughout their lives. Students will also be able to attend chapter events, on-campus activities, and regional and state conferences with students from other colleges.

The Greek Letters in our name were selected because they are the initials from Greek words that mean Excellence, Knowledge, and Wisdom. Sigma Psi is the Cypress College chapter. We not only acknowledge our members as outstanding scholars, but also as humanitarians who devote their time to help our campus and our community.

For more details visit www.CypressCollege.edu and click on Clubs/Programs for more information.

Eligibility requirements

To be eligible for membership in AGS you must meet either one of the following requirements:

1. Temporary Membership: You are a first semester college student and you are a life member of the California Scholarship Federation (CSF), or you graduated from high school with a cumulative GPA of 3.5 or higher.
2. Initial/Continuing Membership: You are a continuing college student who has completed at least 12 semester units with a cumulative GPA of 3.0 or higher.

Honors Program



The Cypress College Honors Program is designed to encourage talent and ability in highly motivated students as they begin their academic studies and prepare to transfer to a four-year college or university. Students who complete the Honors Program and meet all major transfer requirements will have priority consideration for admission to specific four-year institutions.

Classes are taught by faculty interested in enriching the students' academic experience with special projects, readings and class activities. The Program provides a unique, seminar environment with close academic and social interaction with outstanding faculty and other highly motivated honors students. Guest speakers, cultural events and field trips enhance the challenging and creative learning experience.

The Transfer Alliances

Cypress College is a member of the Honors Transfer Council of California. This group has established transfer alliance agreements with four-year colleges and universities.

Honors Courses

ART 112HC	Honors Survey of Art History II	3
ANTH 101HC	Honors Biological Anthropology	3
ANTH 102HC	Honors Cultural Anthropology	3
ASTR 116HC	Honors Intro to Astronomy	3
ASTR 117HC	Honors Astronomy Laboratory	1
BIOL 101HC	Honors General Biology	5
CHEM 103HC	Honors Chem in a Changing World	3
COUN 135HC	Honors Leadership	3
COUN 160HC	Honors University Transition	1
ECON 100HC	Honors Principles of Economics	3
ECON 105HC	Honors Principles of Economics	3
ENGL 100HC	Honors College Writing	3
ENGL 102HC	Honors Introduction to Literature	3
ENGL 104HC	Honors Critical Analysis and Lit	4
ENGL 125HC	Honors Film	3
ENGL 230HC	Honors Thematic Topics	3
ENGL 231HC	Honors Fiction Topics	3
ENGL 234HC	Honors Shakespeare	3
ETHS 100HC	Honors American Ethnic Studies	3
GEOG 100HC	Honors World Geography	3
GEOL 100HC	Honors Physical Geology	3
HIST 110HC	Honors West. Civilizations I	3
HIST 111HC	Honors West. Civilizations II	3
HIST 112HC	Honors World Civilizations I	3
HIST 113HC	Honors World Civilizations II	3
HIST 170HC	Honors History of the U.S.	3
HIST 171HC	Honors History of the U.S.	3
INDS 120HC	Honors Theme Seminar	1
MUS 118HC	Honors Introduction to Opera	3
NURS 105HC	Honors Cardiopulmonary Nursing	1/2
PHIL 100HC	Honors Introduction to Philosophy	3
POSC 100HC	Honors U.S. Government	3
PSY 101HC	Honors General Psychology	3
SOC 101HC	Honors Intro to Sociology	3
SPAN 101HC	Honors Elementary Spanish I	5
SPAN 102HC	Honors Elementary Spanish II	5
SPCH 100HC	Honors Human Communication	3
SPCH 220HC	Honors Rhetoric of the City	3
THEA 102HC	Honors World Theater History	3
THEA 107HC	Honors Diversity in American Theater	3

Requirements for Entrance

- Minimum 3.25 GPA in high school course work or a minimum of 3.0 GPA in 6 units of college course work, verified by transcripts.
- Eligibility for ENGL 100 C.
- Completion of the Honors Transfer Program application.

To Continue in the Program

- Achieve grades of “C” or higher in all Honors classes.
- Maintain a minimum 3.0 GPA in all Cypress College course work.
- Complete a minimum of one Honors Course each semester.

To Complete the Program

- Complete six (6) Honors designated classes for a minimum eighteen (18) units.
- Complete COUN 160HC Honors College/University Transition and INDS 120HC Honors Theme Seminar.
- Complete the requirements necessary to be accepted by the transfer school in your major.
- Complete two extracurricular activities and a Service Learning component each semester.

Benefits for Students while Enrolled

- Increased Scholarship opportunities.
- Small classes with a seminar environment.
- Special counseling and advisement with the Honors Program Director and Honors Counselor.
- Library privileges at transfer colleges and universities.
- Invitation to special Honors Forums, seminars and social events.
- Honors Club Membership.
- Membership opportunities with Alpha Gamma Sigma Honors Society.

Benefits of Completion of the Program

- Priority consideration for admission at the junior level to selected four-year colleges and universities.
- Special recognition at Commencement.
- Honors notation on transcripts.

Applying to the Program

- Submit an application to the Honors Program Office. Applications are available in the Transfer Center or online at www.CypressCollege.edu/academics/specialprograms/honors.
- Submit a current transcript and proof of eligibility for English 100 C.

For more information please contact:

Penny Gabourie, Honors Program Counselor
 pgabourie@CypressCollege.edu

Kathryn Sonne, Honors Program Director
 ksonne@CypressCollege.edu

Honors Program Office is located in the Transfer Center

Located in the Student Center

(714) 484-7452 www.CypressCollege.edu

International Students

Cypress College welcomes applications for its International Student Program. Our college is authorized under Federal law to enroll non-immigrant alien students. One of the goals of the program is to provide positive educational opportunities for students in an effort to improve the global community. The staff offers assistance with academic advisement, registration into classes and orienting students to living in Southern California.

- F-1 students are required to pay a non-resident tuition and enrollment fee. This fee is determined by the Board of Trustees each year and is due at the time of registration.

- Only persons who qualify for F-1 student visas are eligible for admission.
- Deadlines for the acceptance of applications from international students are July 1 for the Fall semester and December 1 for the Spring semester.
- The fee for the necessary special handling and processing of the application package of non-resident F-1 students is \$40.00.
- The F-1 visa student is required to complete a full-time program (12 units or more) each semester of attendance and maintain a 2.0 GPA.
- Enrollment of F-1 students is limited to a maximum of six semesters.
- **Criteria for acceptance of International Students:**
 1. The applicant must possess knowledge of the English language sufficient to result in a Test of English as a Foreign Language (TOEFL) score of 500 (written), 173 (computerized), or 61 (IBT, Internet-Based Test). Students already in the United States may take the Cypress College assessment test.
 2. The applicant must offer evidence of a degree of academic achievement the equivalent of an American high school education, twelve years of elementary and secondary school, or be at least 18 years of age. The student must submit a transcript of an official school record accompanied by a notarized English translation.
 3. The applicant must offer evidence of financial responsibility.
 4. The applicant has attended other American schools or colleges may be considered for admission provided the applicant meets Cypress College admission requirements and can show proof of a valid immigration status with the U.S. Citizenship and Immigration Services (USCIS).
 5. After the completion of the above requirements, the applicant will be considered for admission and will be notified of his/her acceptance or non-acceptance. If accepted, the applicant will also be sent a SEVIS I-20 form and registration information.
- F-1 visa students are held to the same scholastic requirements and to the same college rules and regulations as other students.
- F-1 visa students are required to purchase health insurance in the United States. Such insurance should include major medical coverage to protect the student against financial catastrophe. Students are required to provide proof of health insurance covering the full semester of current enrollment. Monthly or quarterly premiums are not acceptable.
- F-1 visa students will be recommended for employment only in accordance with the rules and regulations established by the U.S. Citizenship and Immigration Services (USCIS).
- F-1 visa students will not be accepted for admission into any program when applications by qualified U.S. citizens exceed space available.

F-2 Dependents

In accordance with U.S. Federal Code, the spouse and minor children accompanying an F-1 student are eligible for admission in F-2 visa status. The F-2 spouse or F-2 child may not engage in full-time study and may only engage in study that is avocational or recreational in nature.

Legacy Program: Celebrating the Black Experience

Established in 2000, the Cypress College Legacy Program is the first community college program in Orange County to concentrate on Black Studies. Set in a positive academic environment, students create a close bond with both peers and their professors as they participate in a variety of events both on and off campus. By offering interesting and rewarding curriculum that focuses on the Black experience, students that complete the program are prepared to transfer and excel in university level work. The program consists of three academic components and sponsors a number of extra-curricular activities designed to enhance the college experience for its members.

ENGLISH — Legacy members take English 060 C, English 100 C and English 104 C. These classes work to improve students' basic written language skills, enhance their research methods, and develop critical thinking. Legacy Program members will become more confident writers as they explore African American culture and literature.

COUNSELING — Counseling is a vital component of the program and to the success of its members. A counselor is available to students each semester. Students are required to work closely with their counselor to explore career options, develop an academic education plan, identify lifetime goals, and discuss personal concerns. Counseling 150 C is linked with English 060 C during the first semester of the program.

ETHNIC STUDIES — While taking English 100 C and English 104 C, students will be concurrently enrolled in Ethnic Studies 129 C: Introduction to African-American Studies and Ethnic Studies 130 C: African-American History I. These classes “share” curriculum so that students will be able to take material they learn from both classes to improve their knowledge, appreciation and understanding of African American culture.

EVENTS AND EXCURSIONS — The Legacy Program sponsors a number of events and trips throughout the year that provide cultural enrichment for all students. Members visit museums, see plays and films, and attend cultural events that relate to the Black experience. Students also visit UC and CSU campuses and are exposed to the opportunities that await them as they prepare to transfer.

The Legacy Program is an excellent opportunity for students to learn about African American culture while at the same time developing the skills necessary to be a successful college student. Students completing the program earn 13 transferable general education units to the UC system and 16 to the Cal State system. Contact Joseph Melodia at jmelodia@CypressCollege.edu or Renee Ssensalo at rssensalo@CypressCollege.edu for information on how to become a member of this special program.

Puente Program

Puente (Spanish for “bridge”) is a national award-winning program that helps students reach their dreams of college success. For more than 25 years, the Puente Program has improved the college-going rate of tens of thousands of California’s educationally underrepresented students. Established in 1996 at Cypress College, the mission of the Puente Program is to increase the number of educationally underserved students who enroll in four-year colleges and universities, earn college degrees, and return to the community as mentors and leaders to future generations. Co-sponsored by the University of California and the California Community Colleges, Puente is open to all students eligible for English 060 C and COUN 150 C.

Puente's interdisciplinary approach combines writing, counseling, and mentoring in a two-semester program.

ENGLISH — Puente students take two consecutive writing classes, **English 060 C and English 100 C**, to improve their written language skills, enhance their research methods, and develop critical thinking while exploring Latino issues in a supportive and stimulating environment.

COUNSELING — Puente students take two consecutive counseling classes, **Counseling 150 C and Counseling 160 C**, to improve their study skills, explore career options, develop an academic educational plan, and identify lifetime goals.

MENTORING — Puente students are matched with a Mentor from the business or professional community who shares her/his personal, academic, and career experiences to provide a window into “real life” work environments. Puente students also work with Peer Mentors, Puente Program graduates, who offer tutoring, guidance, support, and encouragement.

SPECIAL ACTIVITIES — Puente students participate in a number of events on and off-campus, including dinners, a graduation banquet, and guest speakers; field trips to the theater, museums, and bookstores; tours of universities and botanical gardens, and student-organized beach bonfires. These special activities are designed to enrich students' educational, cultural, and social opportunities.

For more information on joining this award-winning program, please contact Mr. Obed Silva, Puente English Instructor at osilva@CypressCollege.edu or Dr. Therese Mosqueda-Ponce, Puente Counselor at (714) 484-7180.

Service Learning

Service Learning is a teaching method that promotes student learning through active participation in meaningful and planned service experience in the community that is directly related to the course content. Through reflective activities, students enhance their understanding of course content, general knowledge, sense of civic responsibility, self-awareness and commitment to the community.

- Incorporate community service into your general education courses
- Apply course skills in a realistic environment
- Explore career options in a course setting
- Increase civic awareness of the community
- Experience a hands-on teaching method
- Strengthen the ethic of service
- Transfer service learning hours to a four year institution

For more information please contact:

Kathryn Sonne, Service Learning Director
ksonne@CypressCollege.edu

Service Learning Office is located in the Transfer Center
 Located in the Student Center
 (714) 484-7452 www.CypressCollege.edu

Special Admit Program

The Special Admit Program is intended for K–12 students who wish to enroll part time in **advanced scholastic or vocational** classes while concurrently enrolled at another school.

To be eligible for the Special Admit Program during the Summer, Fall or Spring semesters, students must complete the Special Admit Form obtaining required recommendations and signature from the principal with parental or guardian permission and approval from a Cypress College counselor. In certain circumstances the signature of a division dean and the college president is required.

Special Admit Students are required to meet all college admission requirements, attend assessment/orientation and meet course prerequisites. Special approval is required for full-time enrollment, persons under age 18 who are/are not enrolled in school, and home school students. Enrollment into specific courses where content is deemed not appropriate for minors by the department may also require special approval. Students on F-1 or F-2 visas are not eligible to enroll as Special Admit Students.

Enrollment fees are waived for California resident Special Admit Students in grades 9–12 who are enrolled in .5–11 units. Per Education Code 76300 Special Admit Students registered in more than 11 units per semester are required to pay enrollment fees for all enrolled units. Special Admit Students who are in grades K–8 are required to pay the enrollment fees for all enrolled units. Students who do not pay the required fees may be dropped from courses for non-payment. All Special Admit Students are responsible for all other college fees including lab, health, parking, books, materials and other required fees.

To change enrollment status at the college, Special Admit students graduating from high school prior to the next college semester must bring to the Admissions and Records Office their diploma or high school transcript indicating their graduation date.

Courses taken by a Special Admit Student are recorded on the student's permanent record as college credit in the same manner as regularly enrolled college students. Credit may be given at the high school and may meet a graduation requirement; however, students should first consult with the high school counselor. Special Admit Students must adhere to all college policies on admission, registration, course requirements, attendance, Student Code of Conduct, and all other applicable policies and procedures.

Students wishing to enroll under the Special Admit Program can download the Special Admit Recommendation Form from the college website or obtain them from the Admissions and Records Office. The Special Admit Recommendation Form is valid for the current semester only. A new Special Admit Form must be submitted for enrollment in subsequent semesters. Students must also file the online College Application for Admission by accessing the college website and applying on CCCApply.

All student records are protected under the Family Educational Rights and Privacy Act (FERPA) of 1974. **No one (including parents and high school officials) can access confidential information without the student's written consent.**

Study Abroad Program

The Study Abroad Program provides students the opportunity to enrich their educational experience by studying abroad for one semester or for a shorter period of time, depending on course offerings, while earning Cypress College units. The program is designed not only to enrich course content by their location in the country where they are offered, but also to provide students with a multi-cultural experience by living in a society and environment different from that of the United States.

Classes offered will be taught by Cypress or Fullerton College instructors, ensuring complete transferability to other United States colleges. There is an application process for interested students, with prerequisites, interviews, and the final selection. Interested students may contact the Fine Arts Division. For further information, call (714) 484-7139.

Teacher Preparation Program

Program Code: 1T07860

The Teacher Preparation Program at Cypress College is a comprehensive student services program that provides academic support, specialized counseling, and outreach to students who are interested in pursuing a career in teaching. The primary purpose of the program is to provide Cypress College students with a clearinghouse of information and resources to help them become teachers. The program also provides early fieldwork experience in an educational setting, as well as opportunities to serve in the “Educational Ambassadors” program. The program offers special classes called Teacher Preparation Classes. These classes are designated with an apple in the Class Schedule. These classes are designed to enhance the future teachers’ understanding by providing a variety of different experiences in the classroom related to the field of Education.



TEACHING CREDENTIAL PREPARATION

There are several types of credentials offered by the state of California that students can receive. Students interested in teaching at the elementary school level will be obtaining a Multiple Subject Teaching Credential. The students interested in teaching at the middle school or high school level will earn a Single Subject Teaching Credential. Most California Teaching Credentials take five years to complete on a full-time basis. The required lower division courses may be completed at Cypress College. For more information, log on to the California Commission on Teaching Credentialing website at: www.ctc.ca.gov.

CALIFORNIA BASIC EDUCATIONAL SKILLS TEST (CBEST)

The CBEST verifies proficiency in reading, mathematics, and writing. Passing the CBEST is a requirement for obtaining a teaching credential issued by the California Commission of Teacher Credentialing and is required prior to student teaching. It is strongly recommended that students seeking a teaching credential take the CBEST after completing category A and B4 in the CSU/GE Requirement or Area 1 and Area 2 in the IGETC/GE Requirements. CBEST review classes are offered periodically throughout the year. Check the Class Schedule for specific dates. Students should pass the CBEST before leaving Cypress College. For more information about the CBEST exam, log on to www.cbest.nesinc.com.

CALIFORNIA SUBJECT EXAMINATIONS FOR TEACHERS (CSET)

All applicants for an elementary teaching credential must prove they are knowledgeable and competent in the subject area(s) they will be licensed to teach. For the middle or high school teacher, subject matter competence focuses on a particular subject such as English or Math. The secondary teaching credential does not require the CSET as long as the student is in an “approved program” and majors in the same subject of their credential. For the elementary teacher, subject matter competence must be demonstrated for all subjects relevant to the elementary classroom through the CSET exam. The exam is divided into subtests (most exams have three subtests) and the examinee has five hours to complete it. Passing the CSET is required for those students who pursue the multiple subject credential. For further information, visit the CSET website at: www.cset.nesinc.com.

CSULB (ITEP) ELEMENTARY PROGRAM AND CSUF (STEP) ELEMENTARY PROGRAM

The Teacher Preparation Program curriculum fulfills all the lower division requirements for the CSULB (ITEP) and CSUF (STEP) Integrated Teacher Education Programs. Upon completion of the integrated program, a student will meet requirements for both a B.A. in Liberal Studies and preliminary multiple subject teaching credential for teaching grades K through 8th, without having to enroll in a year-long credential program. Applications and further information are available in the Teacher Preparation Program Office in the Division of Social Sciences, Humanities, Room 238.

MULTIPLE SUBJECT TEACHING CREDENTIAL

A Multiple Subject Teaching Credential authorizes the holder to teach in a “self-contained” classroom, meaning that one teacher teaches all subjects to the same students. A student will earn a Bachelor’s degree, preferably in Liberal Studies or Child Development (but not exclusively), pass the California Basic Education Skills Test (CBEST), complete a multiple subject teacher credential program, pass a U.S. Constitution class, pass the California Subject Examination (CSET), pass the Reading Instruction Competency Assessment (RICA), and clear a Character and Identification Clearance. All of the California State Universities now have a statewide agreement that they will all use the same 45 units of common core for all Integrated Teacher Preparation Programs in the State of California.

SINGLE SUBJECT TEACHING CREDENTIAL

A Single Subject Teaching Credential authorizes the holder to teach a particular subject at the middle school or high school level. Specific Single Subjects are: Art, Business, English, Health Science, Home Economics, Industrial and Technology Education, Language (other than English), Math, Music, Physical Education, Biological Sciences, Chemistry, Geosciences, Physics, and Social Science. A student will need to earn a Bachelor’s degree (preferably in the subject taught), pass the California Basic Education Skills Test (CBEST), complete a teaching credential program, pass a U.S. Constitution class, pass the Reading Instruction Competency Assessment (RICA), and obtain a Character and Identification Clearance.

EDUCATION SPECIALIST CREDENTIAL (Special Education)

The person holding this credential may work with elementary, middle school, or high school students. An Education Specialist Credential offers the following specializations: Mild to Moderate Disabilities, Moderate to Severe Disabilities, Visual Impairments, Deaf and Hard-of-Hearing, Physical and Health Impairments, and Early Childhood Special Education. A student will need to earn a Bachelor's degree, pass the California Basic Education Skills Test (CBEST), complete a teaching credentialing program, pass a U.S. Constitution class, pass the California Subject Examination (CSET), pass the Reading Instruction Competency Assessment (RICA), and obtain a Character and Identification Clearance.

INFORMATION

For specific academic advisement at Cypress College, contact the Teacher Preparation Counselor, Velia Lawson (714) 484-7015, Student Center, 2nd floor, Counseling or for all other inquiries, contact Nina DeMarkey, Dean Social Sciences Division, Humanities Room 238, (714) 484-7185. The Teacher Preparation Office has a list of all the Cypress classes you will need to take for transfer to a CSU or other University. The Cypress Teacher Preparation website is: <http://CypressCollege.edu/academics/specialprograms/TeacherPrep/TeachPrepprogram>.

** Students with a criminal record are strongly recommended to see the Teacher Preparation Coordinator to find out their eligibility in the program.

NOTE: Students interested in Teaching should use the program code to indicate their area of interest for the Liberal Arts degree.

Student Support Services

The hours listed here are the normal hours of operation for the various offices for the Fall and Spring semesters. The Summer hours may be different (consult the Summer Class Schedule) and all hours are subject to change.

ADMISSIONS AND RECORDS

Admissions and Records is the first contact students will generally have with Cypress College. The Office provides clear and concise information to all members of the community, and admits and registers students in a timely and proficient manner. The Office provides supportive contacts with students, faculty and the administration by maintaining and retrieving student records. The Admissions and Records Office serves as the final evaluator of all certificate and graduation applications, distributes student records (including grades and transcripts) and certifies and reports attendance data to appropriate agencies.

The Admissions and Records Office is located on the first floor of the Student Center. For information, call (714) 484-7346.

NORMAL HOURS OF OPERATION:

MON–THU	8:00 am– 6:00 pm
FRI	8:00 am–12:00 pm

ADULT RE-ENTRY PROGRAM

The Adult Re-entry Program recognizes that learning is a lifelong process and is dedicated to meeting the needs of “non-traditional” students. Our Program provides a combination of services to explore career, academic and success issues as you progress on your educational path. Let us help you discover the many opportunities, services and options available. The Program offers counseling, classes, workshops, resources and referrals. The Adult Re-entry Program is located in the Career Planning Center on the second floor of the Student Center. For information call (714) 484-7120 or visit our website at:

CypressCollege.edu/services/counseling/adultreentryprogram.aspx

NORMAL HOURS OF OPERATION:

MON–THU	8:00 am– 6:00 pm
FRI	8:00 am–12:00 pm

ARTICULATION STATEMENT

Articulation agreements define how courses will transfer from one institution to another. Cypress College maintains major and/or course-to-course articulation agreements with most public universities and many independent colleges and universities in the state of California. The agreements with the public institutions are listed on **www.assist.org** which is the official repository for articulation in the state. Many independent institutions have articulation information available on their websites. In addition, agreements with public and independent institutions are located in the Transfer Center. For more information call (714) 484-7129.

ASSESSMENT CENTER

The Assessment Center provides a variety of services to determine skill levels in grammar, reading, and mathematics. The Center is one of the main components of matriculation services offered to each student. The purpose is to place students in courses which match the students' skills, needs, and goals with college courses, programs and services.

Testing available on a walk-in basis. The Assessment Center is located on the second floor of the Student Center. For information call (714) 484-7223.

NORMAL HOURS OF OPERATION:

MON–THU	8:30 am– 5:00 pm
FRI	8:30 am–12:00 pm

BOOKSTORE

All textbooks and supplies will be available for purchase in the bookstore at least two weeks before each semester or mid-semester class begins. The bookstore also offers special orders for those books that students cannot find in area stores.

The bookstore also offers supplementary educational books and supplies. The supply section offers imprinted Cypress College logo clothing, gifts, greeting cards, snacks, candy, beverages and general merchandise.

You may also rent or purchase textbooks and e-books online at: www.CypressCollegebookstore.com.

NORMAL HOURS OF OPERATION:

MON–THU	7:45 am– 6:00 pm
FRI	7:45 am–12:00 pm

For your convenience the bookstore is open the first Saturday at the start of the Fall and Spring Semesters. Hours for the Summer session and holidays will be posted outside the bookstore as necessary. For additional information call (714) 484-7336.

BOOK BUYBACK

Students may sell their textbooks and certain workbooks back to the bookstore, or wholesale buyer, during the first three days of classes and during Fall/Spring Final Exams, and the first two days of mid-semester classes.

NORMAL BUYBACK HOURS:

MON–THU	8:30 am– 5:00 pm
FRI	8:30 am–12:00 pm

BURSAR

The Bursar's Office processes registration payments and registration refunds, accepts deposits and processes requests for expenditures for a variety of areas on campus including Associated Students and all campus clubs, and monitors campus fundraising activities. This office is also responsible for paycheck disbursement and disbursement of scholarship funds. The Bursar's Office is located on the first floor of the Student Center. For information, call (714) 484-7317.

NORMAL HOURS OF OPERATION:

MON–THU	8:00 am– 5:00 pm
FRI	8:00 am–12:00 pm

CAMPUS SAFETY

The Cypress College Department of Campus Safety is committed to providing a safe campus environment for its students, faculty, and visitors. Campus Safety provides security and safety services to the campus. The department is responsible for crime prevention and personal safety. While this is our primary responsibility, personal safety and crime prevention does rest with each individual. Therefore, each of us must take personal responsibility for our own safety, as well as for the safety of those around us.

Cypress College is among the safest colleges in the country. We strive towards this goal by providing proactive patrol procedures, interaction with the community, and high visibility. We have also established a partnership with the Cypress Police Department. This combination has been successful in solving many of the problems and issues that have been presented to Cypress College members.

Campus Safety provides coverage to the campus 24 hours a day. Campus Safety is located on the Business Building, first floor adjacent to parking lot 1. The Business Office is open 8 am–5 pm; an outside box is available for deposit of citation appeals. Any criminal action or emergency must be reported to Campus Safety at (714) 484-7387.

Cypress College complies with the Standardized Emergency Management System (SEMS) and the National Incident Management System (NIMS) by conducting emergency exercises each semester.

Campus Safety provides escort service upon request at (714) 484-7387. Lost and found items are housed in the Campus Safety Office. Contact Campus Safety to receive information regarding items.

PARKING

Anyone who chooses to use the campus parking lots are required to pay a parking fee. A parking permit for the semester may be purchased through WebStar when students register, or in the Bursar's Office or Admissions and Records Office after the semester begins. A one-day permit may be purchased at the seven permit machines located throughout the campus. The parking permit or one-day permit authorizes students to use any of the six lots open to student parking, as well as designated spots on Circle Drive, Fullerton College and the Anaheim Campus. The parking permit does not guarantee a parking space, but will permit parking in designated spaces. Students or visitors are not eligible to park in staff spaces.

A valid permit should be displayed in or on all vehicles at all times while in the designated parking spaces. Only persons with a valid state placard may park in disabled parking, student parking and limited parking zones. A valid student permit or day permit must be displayed along with the state placard when parking on campus.

PARKING ENFORCEMENT AND APPEALS

All campus parking regulations are enforced by the Cypress College Campus Safety Department. All traffic regulations are enforced by the Cypress Police Department.

Parking is strictly enforced and there is a two-week grace period at the beginning of the Fall and Spring semesters in order for students to obtain permits. Failure to display a parking permit will result in a parking citation issued by Campus Safety. Please contact Campus Safety regarding the appeal process by calling or visiting the Campus Safety website.

CAREER PLANNING CENTER

The Career Planning Center offers services designed to assist students and the general public to move forward with confidence, new skills and strategies for success. Visit the Career Planning Center to discover your career/major options, target your ideal career, clarify your preferred values, interests and activities, and perfect your job search. The Center offers one-on-one counseling to help with selecting a college major, occupational possibilities, career goal alternatives and all aspects of the career search process. Also available are career classes, career assessments, workshops, a research library, career-related software programs and much more. The Career Planning Center is located on the second floor of the Student Center. For information call (714) 484-7120 or visit our website at: www.CypressCollege.edu/services/cpc.

NORMAL HOURS OF OPERATION:

MON–THU	8:00 am– 6:00 pm
FRI	8:00 am–12:00 pm

CENTER FOR INTERCULTURAL UNDERSTANDING

The Mission of the Center for Intercultural Understanding (CIU) is to enrich our learning community through intercultural understanding. The goals of the CIU are to 1) celebrate diversity, 2) promote human relations, 3) disseminate information, 4) provide a forum for dialogue, 5) build community relations, and 6) support globalization/internationalization of curriculum. The Diversity Committee, which oversees the CIU, meets monthly during the academic year. For information, call (714) 484-7049 or 7050.

COUNSELING AND STUDENT DEVELOPMENT

The College maintains a complete guidance service, including the orientation of new students to a successful college experience, counseling to meet the educational requirements for various careers, assistance in selection of courses of study, and individual guidance in matters of aptitude and personal adjustment as they are related to the student's vocational and educational objectives.

Each student is assigned a counselor based on a major or area of interest. The counselor assists the student in planning a program of courses and is available to help in other matters affecting the student's progress in college. Regular conferences may be scheduled during each semester to ensure that the student may gain the greatest possible benefit from the counseling service. Counselors can also be reached by email during the semester at onlinecounselor@CypressCollege.edu or through their individual email address listed in the Programs and Course Descriptions section of this catalog under Counseling and Student Development.

Special courses are offered to assist students in gaining the maximum benefit from their college experience. For example, all students enrolled in more than two classes must enroll in *COUN 140 C* or *COUN 140HC* during their first semester of attendance. This course is designed to further help orient students to college life and assist students in their educational and vocational planning. In addition, there are opportunities for students to take mini-guidance courses in *Career and Life Planning*, *Academic and Life Success*, *Career Exploration*, *College/University Transition*, and *Academic Success and College Survival*.

COUNSELING 140 C

First-time students who are taking more than two classes or who plan to earn the Associate Degree, obtain a certificate, or transfer to a four-year college must include *Educational Planning COUN 140 C* in their schedule. This nine-hour course is taught by a counselor and the class is usually comprised of students with similar majors and/or interests. It is designed to assist the first-time college student with adjustments to college and meeting the educational demands of the college. A large component of the curriculum deals with planning the student's program for the following semesters, depending upon whether the ultimate goal is to complete an Associate degree, a vocational certificate, or whether it is to transfer to a four-year college.

DISABLED STUDENTS PROGRAM AND SERVICES (DSPS)

Services are offered to students with verified disabilities who are enrolled in the college. Disabilities may include: mobility impairments, visual impairments, hearing impairments, learning disabilities, head injuries and psychological impairments. Accommodations are tailored to the student's individual needs with the goal of integrating the student into all facets of college life. DSPS is located in the Cypress College Complex on the first level, Room 100.

Typical services include:

- Complete assessment/evaluation for learning disabilities
- Academic, vocational and personal counseling
- Information and referral
- Registration assistance
- Test taking assistance
- Sign Language Interpreters
- Alternate media

Special classes:

- Adapted Physical Education
- Wheelchair Basketball

Special equipment: (located in our High Tech Center)

- JAWS
- Braille printer
- CCTV
- Large screen computers

Please call for appointments.

Phone (714) 484-7104

TDD (714) 761-0961

FAX (714) 826-4042

NORMAL HOURS OF OPERATION:

MON, TUE, THU	8:00 am– 5:00 pm
WED	8:00 am– 6:00 pm
FRI	8:00 am–12:00 pm

EXTENDED OPPORTUNITY PROGRAMS AND SERVICES (EOPS)

The Extended Opportunity Programs and Services (EOPS) is a state and college funded program designed to assist students with economic, linguistic, and educational challenges (as defined by Title V) enroll and succeed in higher education. Comprehensive support services are provided to promote access to colleges, increase retention, and/or transfer to four-year universities and colleges.

These services include:

- Outreach, Recruitment and Specialized Orientation
- Enhanced Tutoring
- Computer Lab with Internet Access
- Specialized Counseling and Advisement
- Priority Registration
- Textbook Service
- Educational Supplies and Materials
- University Application Fee Waivers

COOPERATIVE AGENCIES RESOURCES FOR EDUCATION (CARE) PROGRAMS AND SERVICES

The CARE (Cooperative Agencies Resources for Education) program provides additional services and grants to eligible EOPS single parents who are on public assistance.

Through CARE, eligible EOPS students receive supplemental educational support services, such as counseling and advisement; group support; peer networking; help from peer advisors; information and referrals to campus and community-based services or agencies; networking activities specifically designed for low-income single parents; and workshops, including self-esteem, parenting, study skills, and time management. Grants and allowances for child care, bus passes, textbooks and school supplies; transportation costs and other educational support; personal computer access; on-campus meal tickets are provided to enhance the retention, persistence, graduation and transfer rates of these highly motivated students.

If you are a single parent and interested in receiving benefits available to you, contact Kelly Grimes, CARE Coordinator at (714) 484-7237. The office is located in the Cypress College Complex on the second floor in Room 201.

The EOPS and CARE staff are composed of dedicated professionals and student workers who are committed to seeing you succeed in college. Services are free of charge to all EOPS eligible Cypress College students.

To find out more about us visit our website at: <http://CypressCollege.edu/services/eops/> or come to our office located in the Cypress College Complex, 2nd floor or contact us at (714) 484-7368.

NORMAL HOURS OF OPERATION:

MON–THU	8:00 am– 6:00 pm
FRI	8:00 am–12:00 pm

CalWORKS

The CalWORKS (California Work Opportunity and Responsibility to Kids) program provides services to Cypress College students who are receiving Temporary Aid to Needy Families (TANF).

Through the CalWORKS program, students may be eligible for paid work study opportunities; child care; academic guidance and counseling; ancillary funds for books and supplies; work activity progress report form completion; communication assistance with the Department of Social Services; workshops to enhance living skills; and networking activities.

Staff is not employed by the Social Services Agency (SSA). They are employed by the North Orange County Community College District as advocates of self-sufficiency through education for our students. If you are attending Cypress College and receiving TANF, please contact the CalWORKS office at (714) 484-7237. The office is located in the Cypress College Complex on the second floor in Room 201.

FINANCIAL AID

The Financial Aid Office provides a number of important student services, which include:

- Providing information regarding the types of financial aid available;
- Helping collect and complete all necessary financial aid forms and documents; and providing guidance on student loans.

The Financial Aid Office currently administers state and federal grants, loans, and work-study. The most common types of financial aid that Cypress College students are eligible to receive include:

Pell Grants — Federally funded grants for eligible undergraduate students (www.fafsa.ed.gov);

Federal Supplemental Educational Opportunity Grants (FSEOG) — Federally funded grants for eligible undergraduate students;

Cal Grants — State-funded award for eligible students from disadvantaged backgrounds or low-income families who have exceptionally high financial need, to provide them assistance with enrollment fees, living expenses, books, supplies, and transportation (www.csac.ca.gov);

Board of Governors (BOGW) Enrollment Fee Waivers — State-funded waivers of enrollment fees for eligible students;

Federal Work-Study (FWS) funds — Federally funded program that provides wages to eligible students for on-campus employment;

Loans (subsidized and unsubsidized) — Federally administered, low-interest loans to eligible students.

WHO QUALIFIES FOR FINANCIAL AID?

To be eligible to receive most forms of financial aid, a student must show documented “financial need” as determined by the federal government. However, there are a number of other specific federal requirements that must also be met. To be eligible for federal financial aid, you must:

- Be a US citizen, a permanent resident, or an eligible non-citizen;
- Have a valid Social Security Number;
- Have a high school diploma or GED;
- Be enrolled in an eligible program at Cypress College;
- Make satisfactory academic progress in your course work;
- Have complied with US Selective Service requirements (www.sss.gov);
- Have not been convicted of the possession and/or sale of illegal drugs; and
- Not be in default on a student loan or owe a refund on any state or federal grant you may have received in the past.

Students who have been ineligible or disqualified to receive financial aid, should re-apply each year and are encouraged to come in and ask about other resources that may be available to them including filing an appeal for financial aid.

For Information:

Financial Aid Office
Cypress College Complex, 1st floor
9200 Valley View Street
Cypress, CA 90630
(714) 484-7114
www.CypressCollege.edu

NORMAL HOURS OF OPERATION:

MON–THU	8:00 am– 6:00 pm
FRI	8:00 am–12:00 pm

FOOD SERVICES — CAMPUS DINING

There are two areas of food services available on campus during day and/or evening hours. At the Student Center location a variety of foods will be available such as pizza, grilled foods, Asian food and daily specials. Seating is both indoor and outdoor. At the “Bookstore Express” location a variety of sandwiches, salads, snack foods, and cold/hot drinks is available for grab ‘n’ go.

STUDENT CENTER CAMPUS DINING**NORMAL HOURS OF OPERATION:**

MON–THU	7:45 am– 8:00 pm
FRI	CLOSED

BOOKSTORE EXPRESS**NORMAL HOURS OF OPERATION:**

MON–THU	7:45 am– 6:00 pm
FRI	7:45 am– 2:00 pm

FOUNDATION

The Cypress College Foundation supports the work of Cypress College by raising funds and distributing them through scholarships, loans, grants, and the funding of select college programs and projects. A non-profit, tax-exempt organization, the Cypress College Foundation raises its funds through the *Americana Awards Banquet*, one of the premiere events in North Orange County; the *President’s Circle*, composed of some of the very best friends and supporters of Cypress College; the *Cypress College Foundation Golf Classic*; and various other programs and activities, including planned giving. For more information contact the Foundation Office at (714) 484-7126.

NORMAL HOURS OF OPERATION:

MON–FRI	8:00 am– 5:00 pm
---------	------------------

GUARDIAN SCHOLARS

Guardian Scholars is a program committed to supporting ambitious college-bound students exiting the Orange County foster care system. Program benefits include assistance in completing college entrance forms; Financial Aid application assistance, mentoring opportunities, friendship and support. Our program collaborates with Orangewood Children’s Foundation to serve former Orange County foster youth. Additional funding may be available to support transfer costs.

If you are an emancipated or former foster youth and interested in receiving benefits available to you, contact Kelly Grimes at (714) 484-7240. Her office is located in the Cypress College Complex on the second floor in the EOPS Office. The Guardian Scholar application period is between January and May 31st each year.

HEALTH SERVICES

As a registered student at Cypress College you are eligible for basic health services at your center. The Student Health Services Center is an office responsible for the health and wellness of students on campus. Our goal is to promote physical and emotional wellness, prevent illness and injury, provide basic outpatient health services, and to educate students toward taking responsibility for their own health.

There is no charge to see the Physician, Nurse Practitioner, Psychologist, Counselor and/or Nurse. Nominal fees will be assessed for lab tests, immunizations, medications, and special exam procedures. A registered nurse and/or a family nurse practitioner are available at all times. Appointments are recommended to see the doctor, nurse practitioner and psychologist/counselor. Emergencies are seen immediately.

All students are covered by an insurance policy which provides coverage for accidents while on campus during required attendance and while using college-sponsored transportation to and from college activities (private insurance is primary).

To make use of any of these health services or to get further information, contact the Health Center located on the first floor of Gymnasium II building by calling (714) 484-7361, or stop by the Center.

NORMAL HOURS OF OPERATION:

MON–THU	8:00 am– 6:00 pm
FRI	8:00 am–12:00 pm

LOST AND FOUND

Lost items that have been turned in may be claimed at the Security and Information Office, located on the Business Building, first floor adjacent to parking lot 1.

NORMAL HOURS OF OPERATION:

MON–FRI	7:30 am– 5:00 pm
---------	------------------

MATRICULATION

Matriculation is a set of services provided to all students as a means of ensuring their academic success. It is legally defined as an agreement between the college and its students. This legislation ensures that every community college student will be afforded the same opportunity for services and to achieve academic success. The college goal is to make the institution a place of easy access and success for students to achieve their educational goals and economic gain. The five components or services which create an easy step-by-step process to introduce Cypress College students to higher education are:

Admissions: The information contained in the college application becomes part of the student’s official record. This office registers students and records grades, program changes, graduation, and transfer requirements.

Assessment: The purpose is to gather as much information as needed on new students. Counselors review assessment scores, transcripts, current study skills, language skills, goals, majors, career aspirations, and the need for special services. Testing is necessary for a first time student if there are no previous records. Assessing student skills aids in making the best educational choices.

Orientation: Students new to Cypress College prior to registration are required to attend a one and one-half hour group orientation/counseling session. During this session the counselor will review the *College Catalog*, *Class Schedule*, services, programs, certificates, degrees, majors, general college procedures, and college

regulations. The counselor will review with the students their test scores, previous transcripts, course prerequisites, and course selection. Online orientation is available at <http://www.CypressCollege.edu/services/counseling>. After registration, Educational Planning COUN 140 C or 140HC is offered to assist the student in completing their individualized Student Education Plan.

Counseling/Advising: All students are encouraged to visit their counselor and confer with instructors periodically throughout the year. Counselors are also available through their email address, located in the Programs and Course Descriptions section of this catalog under Counseling and Student Development. A Student Educational Plan should be on file in each student's academic record after completion of 15 units. Faculty advising is available through instructors' posted office hours.

Student Progress/Follow Up: Students who excel in their course work are placed on either the Dean's Honor Roll or the President's Honor Roll. Information regarding scholarship and Honors is available within this catalog. Students encountering difficulty in courses are referred to appropriate college services by counselors and instructors. Additional referrals are made to assist students with special needs.

Students may be exempt from the Matriculation services if they are a graduate from an accredited U.S. college or university with an Associate of Arts degree or higher; or matriculated at another college.

Student Rights

All matriculated students have the right to challenge or appeal any step in the matriculation process and may:

1. Enroll in any class where prerequisites are met.
2. Challenge course placement decision.
3. Request a waiver of prerequisites for a course, if it is offered, not validated, or if able to demonstrate previous knowledge.
4. File a complaint of discrimination if prerequisites are being applied in a prejudicial manner.

If you have questions regarding any aspect of these services, please contact the Matriculation Manager at (714) 484-7230.

PATRONS OF THE ARTS

The Cypress College Patrons of the Arts is a non-profit, tax-exempt organization that functions under the auspices of the Cypress College Foundation. It was founded in 1975 to encourage community participation in the college's fine arts programs and exhibits, foster cultural, visual, and performing arts activities at the college, and to raise funds to provide scholarships to talented students in the fields of Art (including MAD — Media Arts Design), Dance, Journalism, Music, Photography, and Theater. Please contact the Cypress College Patrons of the Arts at patrons@CypressCollege.edu or (714) 484-7000 ext. 48203 for further information.

STUDENT HOUSING

Housing is not available on the college campus. Students interested in off-campus housing should contact the Student Activities Office for suggested quarters. A listing of available housing is located on a bulletin board in the Student Activities Center. For questions, call (714) 484-7198.

TRANSFER CENTER

The Transfer Center assists students interested in continuing their education at four-year institutions with an emphasis on reaching the historically underrepresented transfer students. The Transfer Center offers students opportunities to meet with representatives from four-year schools for advisement and to attend workshops and transfer fairs. The Transfer Center houses an extensive transfer resource library including college catalogs, articulation agreements, reference books, college videos, and computer programs for student use.

For more information, visit the Transfer Center on the second floor of the Student Center, or call (714) 484-7129.

NORMAL HOURS OF OPERATION:

MON–THU	8:00 am– 6:00 pm
FRI	8:00 am–12:00 pm

Veterans and Service Members

VETERANS MILITARY SERVICE CONNECTED BENEFIT PROGRAMS

Cypress College is approved as a degree-granting institution for the attendance of veterans under Title 38, United States Code. This includes the programs covered in Chapters 30, 31, 32, 33, 35, 1606, 1607, and VRAP. The College is also approved for the attendance of California veterans' dependents under the State Fee Waiver program.

Veterans who plan to enroll in the College and need assistance with their education benefits are urged to contact the Certifying Official of Veterans Affairs, Christy Davis. The Veterans Resource Center is located on the second floor of the Cypress College Complex.

Student veterans and dependents that plan on using their benefits, or need information regarding priority registration must have all required documents in to the Certifying Official of Veterans Affairs by the following dates so the necessary arrangements may be made with the Veterans Administration or the California Department of Veterans Affairs.

SUMMER	April 15
FALL	June 10
SPRING	October 21

The Veterans Resource Center works closely with Admissions and Records, Academic Counseling, the Student Employment/Financial Aid Office, the Student Educational Development Center, and various veterans agencies to provide the veteran with services contributing to a successful educational experience.

For information:

Phone: (714) 484-7150
 Email: cadavis@CypressCollege.edu

HOURS OF OPERATION FOR FALL/SPRING

MON–THU	11:00 am– 5:30 pm
FRI	8:00 am–12:00 pm

HOURS OF OPERATION FOR SUMMER:

MON–THU	11:00 am– 5:30 pm
---------	-------------------

DISABLED VETERANS

Veterans who qualify for educational benefits as disabled veterans may be entitled to special educational benefits. Veterans should contact:

VA Regional Office
Federal Building
11000 Wilshire Blvd.
Los Angeles, CA 90024-3602
(800) 827-1000
FAX (310) 235-6640

Veterans with disabilities are encouraged to pursue services offered through Disabled Students Programs and Services (DSPS), located on the 1st floor of the Cypress College Complex. Call (714) 484-7104 for assistance.

VETERAN DEPENDENT EXEMPTION

Children and spouses of U.S. Veterans with service connected disabilities may be eligible for waiver of college fees and/or Survivors' and Dependents' Educational Assistance (CH 35). For more information visit the Veterans Resource Center located on the second floor of the Cypress College Complex. Call (714) 484-7150 for assistance.

LIABILITY

The veteran assumes full liability for any overpayment of veteran's benefits.

All persons receiving educational benefits must see the veteran's academic counselor and complete a veteran enrollment form (VEF) every **semester** to continue their benefits. In addition, a Student Education Plan (SEP) must be on file by the end of the first semester; otherwise, certification of VA benefits will be delayed for the second semester. This plan must be developed and reviewed by an academic counselor.

NUMBER OF UNITS REQUIRED

The following number of units is required each semester to qualify for educational benefits for educational and training allowance:

12 units or more	full allowance
9 – 11.5 units	$\frac{3}{4}$ allowance
6 – 8.5 units	$\frac{1}{2}$ allowance
2 – 5.5 units	$\frac{1}{4}$ allowance**

**Chapters 32 and 1606 only

Short-term and summer session courses are computed proportionately for payment purposes.

WITHDRAWAL/CHANGE OF CLASSES

Veterans are required to notify the Veterans Resource Center when they stop attending class, withdraw from the college, or add or drop a class. Such changes should be reported immediately after completing the add/drop procedure through myGateway. Failure to comply with this regulation may result in an overpayment of benefits.

VETERANS ACADEMIC PROGRESS

A veteran student whose GPA falls below a 2.0 for one semester will be placed on academic probation and must submit a progress report to the Veterans Resource Center. Veterans who are on academic probation may have to enroll in an academic/life success class. If the veteran student continues to have a GPA below a 2.0 for two consecutive semesters they will no longer be able to receive educational benefits until a marked improvement has occurred. Please contact the Veterans Resource Center for more information.

REPEATED CLASSES

Veterans may not receive benefits for a repeat of a course in which a grade of "A," "B," "C," "D," or "P" has already been earned. Although District policy allows a student to repeat a course in which a "D" grade has been received, the course may be certified for benefits only if this catalog states that a grade of "C" or better in that course is required to earn a degree or meet a prerequisite.

TRANSCRIPTS

All official transcripts of prior college work and military schools, including copies of form DD214 or DD295 covering all periods of military service, must be on file in the Admissions and Records Office by the end of the first semester of attendance at this college. Certification for benefits for the second semester may be withheld if transcripts are not received. For necessary forms, visit the Veterans Resource Center, located on the second floor of the Cypress College Complex. Call (714) 484-7150 for additional information.

Campus Life

Campus Clubs

Students are encouraged to broaden their horizons by participating in club activities at Cypress College. Clubs are organized to involve the student in specialized fields of interest or service to the college and community. The clubs and organizations at the college can be listed in four categories: academic achievement, cultural, special interest, and religious.

MEETING TIMES

The meeting times for all clubs can be obtained from the Office of Student Activities in the Student Center. The following is a complete list of Cypress' campus clubs and organizations:

- Alpha Gamma Sigma (Honor Society)
- Anime Club
- Anthropology Club
- Aquarium Club
- Biology Club
- Black Student Union
- Campus Christians
- Charger Chronicle
- Court Reporting Club
- C.C. Flying Team (Alpha Eta Rho)
- C.C. Veteran's Organization
- Chemistry Club
- Creative Arts Guild
- Cypress Nursing Student Association (CNSA)
- Dental Assisting Club
- Engineering and Physics Club
- Explorer's Club
- Film Club
- Flight Attendants
- Forensics
- Friends of Diversity
- Future Business and Economics Club
- G.A.L.A.
- L.E.A.D.
- Global Association of Culture and Peace

Honors Club
 Hospitality and Travel Club
 House on Campus
 Human Services
 Invisible Student Union
 Korean Christian Fellowship
 Korean Student Association
 Latter-Day Saints Student Association
 Math Club
 M.E.Ch.A.
 Mortuary Science Club
 Muslim Student Association
 Native American Club
 Outreach Ministries
 Pharmacy Club
 Philosophy Club
 Political Science Club
 Pre-Med Club
 Progressive Students for Change
 Psychiatric Technology
 Psychology Circle
 Radiologic Technology
 Recording and Entertainment Club
 S.A.D.H.A. (Dental Hygiene)
 Society of Future Engineers
 Society of Physics Club
 Sociology on Demand
 Spanish Club
 Spirit Club (Pep)
 S.T.A.N.D.
 Travel Club
 UTAP Club
 Veteran's Club
 Vietnamese Club
 Women's Study Club

ACADEMIC ACHIEVEMENT CLUBS

Alpha Gamma Sigma and the Honors Club are the college's academic clubs. Their main goal is to increase and promote academic excellence among students. The clubs provide service to the school and hold fund-raising activities to earn money for scholarships. Sigma Psi is the campus chapter of Alpha Gamma Sigma and the Honors Club is the support club for the Honors Program.

CULTURAL CLUBS

Cultural clubs provide students with an opportunity to experience other cultures as well as to meet students with similar backgrounds. In addition, they provide a link to the political and social events shaping the world of today.

INTEREST CLUBS

Interest clubs provide a place or event for students to share a common interest or a chance to experience something new.

RELIGIOUS CLUBS

Religious clubs promote a particular religion as well as provide a place for students to come together in their faith.

Dress Code

Students are expected to dress in good taste. Attending class or entering any campus building while barefooted or bare-chested is specifically prohibited.

Intercollegiate Athletic Program

The Cypress College Chargers are members of the Orange Empire Conference composed of Cypress, Fullerton, Golden West, Irvine Valley, Orange Coast, Riverside, Saddleback, Santa Ana, and Santiago Canyon Community Colleges. The Chargers compete in conference competition in the following men's sports: baseball, basketball, golf, soccer, swimming and tennis. Women's intercollegiate sports include: basketball, soccer, softball, swimming, tennis, volleyball and water polo. The Chargers also compete in wheelchair basketball. Cypress students may participate in football, cross-country, track and men's water polo at Fullerton College.

Athletic eligibility rules and regulations adopted by the conference and the California Community College Athletic Association are rigidly enforced at Cypress College. In general, eligibility rules require an athlete be enrolled in 12 units or more at the time of competition. To compete a second season in a sport, an athlete must complete and pass 24 units with a 2.0 GPA between seasons of competition. These must be completed prior to the beginning of the second season of the sport. Transfers who have participated in athletics at another California community college must complete 12 units at Cypress College before becoming eligible. Since this is only a general guideline and athletic eligibility rules are rather complex, questions regarding eligibility should be referred to the athletic director for clarification.

Inter-Club Council (ICC)

The Inter-Club Council (ICC) is financed by the Associated Students of Cypress College and its chair is an elected, voting member of the Associated Student Council. The Inter-Club Council is composed of a representative from each of the recognized clubs on campus. Its function is to coordinate the activities of the various clubs and to provide an organized channel for club support of, or participation in, major campus events. For information regarding current clubs on campus, and/or the forming of new clubs, please stop by the Student Activities Center.

Publications

OFFICIAL STUDENT PUBLICATIONS

Student publications are approved by the college through authorization of the President of the college and the assignment of a faculty advisor. Such publications are eligible for distribution on campus. All student publications are expected to reflect good taste, be written and edited by students of the college, and conform to editorial policies established by the college. These editorial policies shall include authority of the faculty advisor to exercise the right to disapprove materials with provision for the right of the student appeal to persons designated by the college President. Students who violate this policy shall be subject to suspension and/or expulsion.

UNOFFICIAL PUBLICATIONS

Commercial publications may not be distributed or sold on the college campus without specific permission from the President. Non-commercial publications, student or non-student, not sponsored or approved by the college may be distributed on campus under regulations as established by the college. Such regulations may pertain to hours and places of distribution, littering, the orderly operation of the college, the outrage of public decency, and an identification of the persons and/or organizations sponsoring the material. Unofficial publications which do not meet the criteria listed are considered unauthorized and may not be distributed on campus.

Student Activities

The Student Activities Program at Cypress College is intended to achieve the following objectives:

- to provide opportunities for students in shared governance activities;
- to provide students with the opportunity to create and administer their own organizations;
- to provide a leadership development program for credit that will help students learn the practical application of leadership and organizational theory.

Student Activities is an integral part of college life, and all students are encouraged to take an active role in some phase of the student activities program.

Activities include campus clubs, concerts, special interest programming, community awareness and involvement, club rush, Senior Day, World Fest, and Welcome Back Week. The Associated Students Council participates on Campus and District Shared Governance committees to represent student interests.

NORMAL HOURS OF OPERATION:

MON–THU	8:00 am– 5:00 pm
FRI	8:00 am– 5:00 pm

Student Government

Cypress College is committed to student government with the following objectives:

- promoting cultural, educational and social events
- enhancing and supporting class instruction
- recognizing student government as an integral part in the shared governance structure of the college
- facilitating participation in the college community

The governing body of the Associated Students of Cypress College is the A.S. Council, which consists of the Executive Board, the Student Senate, and the Programming Board. Elections for officers on these boards are held during the Spring and Fall semesters. The Student Activities Center houses the A.S. Council. Meetings of the Council are held on Mondays at 11:30 a.m. and are open to anyone who would like to attend.

The A.S. Council plans, organizes, promotes and finances many activities for the campus. A.S. Council officers serve on campus committees and participate in the California State Student Senate to represent student interests concerning campus, district, and statewide decisions affecting community college students. Campus clubs are part of Inter-Club Council (ICC) which is administered by the A.S. Council. For further information, contact the Associated Students at (714) 484-7198.

Administrative Procedures

The most current Administrative Procedures and Board Policies for the North Orange County Community College District can be found at <http://www.nocccd.edu/Policies/PoliciesAndProcedures.htm#BoardPolicies>.

Administrative Procedures 5500 — Standards of Student Conduct and Discipline

Reference: *Education Code Section 66300, 76030, 76033, 76034, 76036*

Cypress College students are expected to maintain satisfactory standards of citizenship at all times on the campus and in the community. The following are guidelines for minimum student conduct. Students enrolling in the college assume an obligation to conduct themselves in a manner compatible with the College's function as an educational institution.

A student who violates the standards of student conduct shall be subject to disciplinary action including, but not limited to, the removal, suspension or expulsion of the student. Misconduct which constitutes "good cause" for disciplinary action includes, but is not limited to, the following:

- 1.1 Disruptive behavior, willful disobedience, habitual profanity or vulgarity; the open and persistent defiance of the authority of, or persistent abuse of, District personnel, or violating the rights of other students.
- 1.2 Failure to identify oneself when requested to do so by District officials acting in the performance of their duties.
- 1.3 Cheating, plagiarism in connection with an academic program (including plagiarism in a student publication), or engaging in other academic dishonesty.
- 1.4 Dishonesty, forgery, alteration, or misuse of District documents, records, or identification, or knowingly furnishing false information to the District.
- 1.5 Misrepresentation of oneself or of an organization to be an agent of the District.
- 1.6 Causing, attempting to cause, or threatening to cause physical injury or physical or verbal abuse or any threat of force or violence, to the person, property, or family of any member of the college community, whether on or off District property as defined above.
- 1.7 Willful misconduct which results in injury or death to a student or to District personnel, or which results in the cutting, defacing, or other damage to any real or personal property of the District.
- 1.8 Unauthorized entry into, unauthorized use of, or misuse of property of the District.

1.9 Stealing or attempting to steal District property or private property on District premises, or knowingly receiving stolen District property or stolen private property on District premises.

1.10 Causing or attempting to cause damage to District property, or to private property on District premises.

1.11 Unlawful use, sale, possession, offer to sell, furnishing, or being under the influence of any controlled substance listed in the California Health and Safety Code, section 11053 et seq., an alcoholic beverage, or an intoxicant of any kind, or any poison classified as such by Schedule D in Section 4160 of the Business and Professions Code or other State law defining controlled substance while on District property, or at a District function; or unlawful possession of, or offering, arranging or negotiating the sale of any drug paraphernalia, as defined in the California Health and Safety Code, section 11014.5.

1.12 Willful or persistent smoking in any area where smoking has been prohibited by law or by regulation of the District.

1.13 Possession, sale, use, or otherwise furnishing of explosives, dangerous chemicals, deadly weapons or other dangerous object including, but not limited to, any facsimile firearm, knife or explosive on District property, or at a District function, without prior written authorization of the Chancellor, college president, School of Continuing Education Provost, or authorized designee.

1.14 Engaging in lewd, indecent, or obscene behavior on District property, or at a District function.

1.15 Violation of municipal, state, or federal laws in connection with attendance in programs or services offered by the District, or while on District property or at District-sponsored activities.

1.16 Soliciting or assisting another to do any act (including the purchasing, transporting or consumption of any controlled substance), while under the supervision of a District official, which would subject a student to expulsion, suspension, probation, or other discipline pursuant to this policy.

1.17 Attempting any act constituting cause for disciplinary action as identified in the above sections of this policy.

1.18 Committing sexual harassment as defined by law or by District policies and procedures.

1.19 Engaging in harassing or discriminatory behavior based on race, sex (i.e., gender) religion, age, national origin, disability, sexual orientation, or any other status protected by law.

1.20 Engaging in physical or verbal intimidation or harassment of such severity or pervasiveness as to have the purpose or effect of unreasonably interfering with a student's academic performance, or District employee's work performance, or of creating an intimidating, hostile or offensive educational or work environment.

1.21 Engaging in physical or verbal disruption of instructional or student services activities, administrative procedures, public service functions, authorized curricular or co-curricular activities or prevention of authorized guests from carrying out the purpose for which they are on District property.

1.22 Stalking, defined as a pattern of conduct by a student with intent to follow, alarm, or harass another person, and which causes that person to reasonably fear for his or her safety, and where the student has persisted in the pattern of conduct after the person has demanded that

the student cease the pattern of conduct. Violation of a restraining order shall, without more, constitute stalking under this policy.

1.23 Persistent, serious misconduct where other means of correction have failed to bring about proper conduct or where the presence of the student causes a continuing danger to the physical safety of students or others.

1.24 Engaging in expression which is obscene, libelous, or slanderous according to current legal standards, or which so incites students as to create a clear and present danger of the commission of unlawful acts on District property, or the violation of the lawful administrative procedures of the District, or the substantial disruption of the orderly operation of the District.

2.0 No student shall be suspended from a college or School of Continuing Education program or expelled unless the conduct for which the student is disciplined is related to college, School of Continuing Education or District activity or attendance.

3.0 Any violation of law, ordinance, regulation or rule regulating, or pertaining to, the parking of vehicles, shall not be cause for removal, suspension, or expulsion of a student.

4.0 The Chancellor shall establish procedures for the imposition of discipline on students in accordance with the requirements for due process of law. The procedures shall identify potential disciplinary actions including, but not limited to, the removal, suspension or expulsion of a student.

5.0 The Chancellor shall establish procedures by which all students are informed of the rules and regulations governing student behavior.

Administrative Procedures 5500 — Student Discipline Procedures

Reference: *Education Code Section 66017; 76030 et seq. Penal Code Section 626.4*

1.0 The purpose of these administrative procedures is to provide a prompt and equitable means to address violations of the standards of student conduct in a manner consistent with requirements of due process of law. Nothing in these procedures is intended to infringe upon the rights of students to engage in the lawful exercise of free expression as protected by the state and federal constitutions and by the provisions of Education Code section 76120.

2.0 Definitions

2.1 **Administrator:** A management employee of the District having significant responsibilities for formulating District policies or administering District programs.

2.2 **District:** The North Orange County Community College District.

2.3 **College:** Cypress College, Fullerton College, and the School of Continuing Education and their respective programs.

2.4 **Student:** Any person currently enrolled as a student at a College or in any program offered by the District.

2.5 **Instructor:** Any instructional employee of the District in whose class a Student subject to discipline is enrolled.

2.6 **Student Discipline Officer:** The official at a College who is responsible for reviewing and processing student discipline matters.

2.7 President: The President of Cypress College, the President of Fullerton College, and the Provost of the School of Continuing Education.

2.8 Day: A day during which the District administrative offices are open for business. The time limits set forth in these procedures for action by the Student Discipline Officer, President, hearing officer or panel, and Board of Trustees are guidelines; failure to strictly adhere to these time limits shall not invalidate any action otherwise appropriately taken hereunder.

2.9 Expulsion: The involuntary removal of a student from the District and all District programs for one or more terms, or permanently, by action of the Board of Trustees.

2.10 Formal Hearing: A hearing conducted before a hearing officer or hearing panel in accordance with section 4.0 of these procedures during which the student and the District may call and examine witnesses and present documentary evidence.

2.11 Informal Hearing: A meeting between the student and the Student Discipline Officer or designee in accordance with section 3.2.3 of these procedures to discuss the charges and provide the student with the opportunity to respond to the charges orally, or in writing.

2.12 Suspension: The involuntary removal of a student for good cause from one or more classes or from the college by the President or designee for a limited period of time, as follows:

2.12.1 Short-Term Suspension: Removal from one or more classes for a period of up to 10 consecutive days of instruction;

2.12.2 Long-Term Suspension: Long-term suspension may consist of:

2.12.2.1 Removal from one or more classes for the remainder of the academic term;

2.12.2.2 Removal from one or more classes for one or more academic terms; or

2.12.2.3 Removal from all classes and activities of the College for one or more academic terms.

A student placed on suspension from one or more classes may not, for the period of the suspension, be enrolled in any class or program at any College in the District that is substantially similar to the class(es) or program(s) from which the student is suspended.

A student placed on suspension from all classes and activities of a College may not be enrolled in any College or program in the District for the period of suspension.

2.13 Removal from Class: The involuntary removal of a student from class by an Instructor for a maximum period of two consecutive class sessions.

2.14 Removal from Facility: The involuntary removal of a student by an administrator from a District or College facility, or facility under the control of the District or College for a maximum period of two consecutive days.

2.15 Disciplinary Probation: A status between good standing and suspension or expulsion. It covers a stated trial period and disciplinary conditions required of the student. At the end of the trial period, it shall be determined, based on whether the probationary conditions have been met, whether the student is to be returned to good standing, suspended, recommended for expulsion, or subject to other disciplinary action.

2.16 Loss of Privileges: Disciplinary action involving the loss of certain student privileges, such as eligibility to participate in extracurricular activities, for a stated period of time.

2.17 Formal Reprimand: Written admonition or warning to cease and desist from conduct that has been determined to violate the standards of student conduct. A formal reprimand becomes part of a student's permanent record and is considered in the event of future violations of the standards of student conduct.

2.18 Informal Reprimand: An oral admonition or warning to cease and desist from conduct that has been determined to violate the standards of student conduct. A record of the fact that an informal reprimand has been given may be retained as part of a student's record for a period of up to one year and is considered in the event of future violations of the standards of student conduct during the period of retention. It is the student's responsibility to request that the record be removed upon expiration of the period of retention.

2.19 Withdrawal of Consent to Remain on Campus: Withdrawal of consent by the President or the President's designee for a student or other person to remain on a College campus in accordance with California Penal Code section 626.4 where the College President has reasonable cause to believe that the student has willfully disrupted the orderly operation of the campus.

3.0 Procedures for Implementing Disciplinary Action

3.1 Removal of Student From Class or From a Facility

3.1.1 Removal From Class by an Instructor: An Instructor may order a student removed from class for good cause. Removal shall be for a maximum period of two class sessions, which shall be the day of the removal and the next class meeting.

Removal From a Facility by an Administrator: For good cause, an administrator may order a student removed from a facility for the day of the offense and the next day.

3.1.2 The student shall be advised of the removal and the reasons therefore. The Instructor or Administrator shall immediately report the removal, through established College administrative channels, to the Office of the President and to the Student Discipline Officer for appropriate action and shall submit, through those channels, a written report describing the conduct warranting the removal to the Student Discipline Officer within ten (10) days of the removal.

3.1.3 The appropriate program administrator or the Student Discipline Officer shall conduct a meeting with the student. If the student is a minor, the Student Discipline Officer shall ask the parent or guardian of the student to attend a parent conference with the Instructor, if the removal was from class, or if the removal was from a facility, with the administrator who ordered the removal, as soon as possible. If the Instructor, administrator, or the parent or guardian so requests, the Student Discipline Officer shall attend the conference.

3.1.4 During the period of removal, the student shall not be returned to the class without the concurrence of the Instructor or, if the removal is from a facility, without the concurrence of the administrator who ordered the removal.

3.1.5 Nothing herein shall prevent the President or Student Discipline Officer from recommending further disciplinary action in accordance with these administrative procedures based on the conduct which prompted the removal.

3.2 Suspension or Expulsion

3.2.1 Except in the case of immediate interim suspension as provided in section 3.3 of these procedures, before implementing disciplinary action to suspend or expel a student, the student shall be provided with a written notice of the conduct warranting the discipline, which shall include:

3.2.1.1 The section(s) of the Standards of Student Conduct the student is charged with violating;

3.2.1.2 A brief statement of the facts supporting the charges;

3.2.1.3 The right of the student to an informal hearing with the Student Discipline Officer or designee to discuss the charges, or to respond in writing; and

3.2.1.4 The nature of the proposed disciplinary action.

3.2.2 The notice shall be provided to the student within thirty (30) days of the date on which the conduct occurred or the date on which an instructor or other official of the District learned of the conduct; or, in the case of continuous, repeated, or ongoing conduct, the notice shall be provided within thirty (30) days of the date of the most recent occurrence. Within five (5) days of receiving the notice, the student may submit to the Student Discipline Officer a written request for an informal hearing, as provided in section 3.2.1.3. In addition to, or in lieu of requesting an informal hearing with the Student Discipline Officer, the student may submit a written response to the charges. Notice is deemed received as of the date it was personally delivered or three (3) days after it was placed in the United States mail.

3.2.3 If the student requests an informal hearing as provided in section 3.2.1.3, the Student Discipline Officer shall hold an informal hearing during which the student shall be given an opportunity to respond orally or in writing to the charges.

3.2.4 Within five (5) days after the informal hearing, or within ten (10) days after the student has received the written notice pursuant to section 3.2.1 and has declined or failed to request a meeting, the Student Discipline Officer shall provide the President with a written recommendation regarding the specific disciplinary action to be imposed, if any, which shall include the factual findings regarding the charges and conclusions as to the standards of student conduct that were violated, if those findings and conclusions differ in any material respect from the initial notice.

3.2.5 Within five (5) days after receipt of the recommendation of the Student Discipline Officer, the President shall render a decision regarding the disciplinary action to be implemented, if any, and shall provide written notice of the decision to the student. The President may accept, modify or reject the recommendation of the Student Discipline Officer.

3.2.5.1 Short-Term Suspension or Lesser Disciplinary Action

Where the decision of the President is to impose short-term suspension or some lesser disciplinary action, the decision of the President shall be final. The written notice to the student of the President's decision shall specify the length of time of the suspension or the nature and duration of the lesser disciplinary action.

3.2.5.2 Long-Term Suspension

3.2.5.2.1 Where the decision of the President is to impose long-term suspension, the student shall have the right to request a formal hearing before the suspension is imposed.

3.2.5.2.2 The written notice to the student of the President's decision shall specify the right of the student to request a formal hearing and shall include a copy of the formal hearing procedures.

3.2.5.2.3 Within five (5) days of receiving the written notice of the President's decision, the student may submit to the President a written request for a formal hearing. Notice is deemed received as of the day it was personally delivered or three (3) days after it was placed in the United States mail. The hearing, if requested, shall be conducted in accordance with the provisions of section 4.0 of these procedures. If the student does not request a hearing within five (5) days of receiving notice, the President's decision shall become final.

3.2.5.2.4 Within five (5) days after receipt of the recommended decision of the hearing officer or panel, the President shall render a final decision regarding the disciplinary action to be implemented, if any, and shall provide written notice of the decision to the student. The President may accept, modify or reject the findings, conclusions and recommendations of the hearing officer or panel. If the President modifies or rejects the decision of the hearing officer or panel, the President shall review the record of the hearing and shall prepare a new written decision which contains specific factual findings and conclusions. The decision of the President shall be final.

3.2.5.3 Expulsion

3.2.5.3.1 A student may be expelled for good cause where other means of correction have failed to bring about proper conduct or when the presence of the student causes a continuing danger to the physical safety of students or others. Only the Board of Trustees may expel a student.

3.2.5.3.2 Where the decision of the President is to recommend expulsion to the Board of Trustees, the student shall have the right to request a formal hearing before expulsion is imposed.

3.2.5.3.3 The written notice to the student of the President's decision shall specify the right of the student to request a formal hearing and shall include a copy of the formal hearing procedures.

3.2.5.3.4 Within five (5) days of receiving the written notice of the President's decision, the student may submit to the President a written request for a formal hearing. Notice is deemed received as of the date it was personally delivered or three (3) days after it was placed in the United States mail. The hearing, if requested, shall be conducted in accordance with the provisions of section 4.0 of these procedures. If the student does not request a hearing within five (5) days of receiving the notice, the President's decision shall become final.

3.2.5.3.5 Within five (5) days after receipt of the recommended decision of the hearing officer or panel, the President shall render a decision regarding the disciplinary action to be implemented, if any. The President may accept, modify or reject the findings, conclusions and recommendations of the hearing officer or panel. If the President modifies or rejects the decision of the hearing officer or panel, the President shall review the record of the hearing and shall prepare a new written decision which contains specific factual findings and conclusions.

3.2.5.3.5.1 Where the decision of the President is to impose suspension or some lesser disciplinary action, the decision of the President shall be final. The student shall be provided with a written notice of the President's decision which shall specify the length of time of the suspension or the nature of the lesser disciplinary action.

3.2.5.3.5.2 Where the decision of the President is to recommend expulsion, the written recommendation of the President shall be submitted to the Board of Trustees for consideration in accordance with section 5.0 of these procedures. The Board of Trustees shall consider the recommendation for expulsion at the next regularly scheduled meeting of the Board following the meeting at which the recommendation was received.

3.2.6 The College President shall report all suspensions of students to the Chancellor.

3.2.7 Whenever a minor student is suspended, the parent or guardian shall be notified in writing by the President or designee.

3.2.8 In cases of assault, the Chancellor or President shall, upon the expulsion or suspension of any student, notify the appropriate law enforcement authorities of any acts of the student which may be in violation of section 245 of the Penal Code.

3.3 Immediate Interim Suspension

The President or designee may order the immediate suspension of a student where there is reasonable cause to believe that immediate suspension is required to protect lives or property and to ensure the maintenance of order. Where a student is placed on interim suspension, the procedural time limits specified in these procedures shall not apply. The student shall be given prompt notice of the charges and all hearing rights, including the right to a formal hearing where a long-term suspension or expulsion is recommended, shall be afforded the student within ten (10) days of the imposition of interim suspension. The student shall not, without prior written permission from the President or designee, enter the campus of any College other than to attend the hearing. Violation of the interim suspension conditions shall be grounds for expulsion.

3.4 Withdrawal of Consent to Remain on Campus

3.4.1 The President or designee may withdraw consent for a student to remain on the College campus, in accordance with California Penal Code section 626.4, where there is reasonable cause to believe that the student has willfully disrupted the orderly operation of the campus. A student who is on campus at the time consent is withdrawn shall promptly leave or be escorted off campus. Whenever consent is withdrawn by an authorized designee of the President, a written report shall be promptly submitted to the President.

3.4.2 Consent shall not be withdrawn for longer than fourteen (14) days from the date upon which consent was initially withdrawn. The student from whom consent has been withdrawn may submit a written request for a hearing to the Student Discipline Officer. The request must be submitted within the period of the withdrawal. A hearing, if requested, shall be held within seven (7) days of the date of receipt of the request. The hearing shall be conducted in accordance with the provisions of this procedure relating to interim suspensions.

3.4.3 A student from whom consent to remain on campus has been withdrawn and who willfully and knowingly enters or remains upon the campus or facility during the period for which consent has been withdrawn, except for the purpose of attending a meeting or hearing on the withdrawal, is subject to arrest.

4.0 Formal Hearing Procedures

4.1 Hearing Officer or Panel

4.1.1 At the discretion of the President, a formal disciplinary hearing may be conducted using the services of a hearing officer, or the President may select an impartial hearing panel comprised of two educational administrators at the level of dean or vice president, one of whom shall be selected from another college within the District.

4.1.2 The President shall appoint one member of the panel to serve as the chair of the hearing panel. The decision of the chair shall be final on all matters relating to the conduct of the hearing.

4.1.3 No administrator who has any direct involvement in the matter to be decided, who is a necessary witness, or who could not otherwise act in a neutral manner shall serve on a hearing panel.

4.2 Notification of Hearing

The student, and the student's parent or guardian, if the student is a minor, shall be notified by registered or certified mail or by personal service of the date, time, and location of the hearing.

4.3 Conduct of Hearing

4.3.1 Prior to the hearing, the members of the hearing panel shall be provided with a copy of the charges against the student and any written response provided by the student.

4.3.2 The hearing shall be closed and confidential.

4.3.3 The student shall have the right to represent himself/herself at the hearing or to be represented by a person of the student's choice, except that neither the student nor the District shall be represented by legal counsel unless authorized by the hearing officer or panel, in which case both parties shall be entitled to be represented by legal counsel.

4.3.4 A record of the hearing shall be made by the District, either by means of tape recording or stenographic recording, and shall be the only recording made. In the event the record is by means of tape recording, the hearing panel chair shall, at the beginning of the hearing, ask each person present to identify himself/herself by name, and thereafter shall ask each witness to identify himself/herself by name. Tape recordings shall remain in the custody of the District at all times, unless released to a professional transcribing service. The student may receive a copy of the tape recording upon request.

4.3.5 Formal rules of evidence shall not apply. Any relevant evidence shall be admitted.

4.3.6 The hearing officer or panel shall not have the authority to issue subpoenas on behalf of either the District or the student.

4.3.7 Charges against the student, along with supporting evidence from witnesses or other sources, will be presented by the District.

4.3.8 The student shall be given the opportunity to confront and cross-examine witnesses.

4.3.9 The student shall be given an opportunity to present a defense, including witnesses and documentary evidence.

4.3.10 The District shall have the opportunity to cross-examine the student and witnesses called by the student.

4.3.11 Unless the hearing officer or panel determines to proceed otherwise, the District and the student shall each be permitted to make an opening statement. Thereafter, the District representative shall make the first presentation, followed by the student. The District representative may present rebuttal evidence after completion of the student's presentation.

4.3.12 All testimony shall be taken under oath; the oath shall be administered by the hearing officer or hearing panel chair. Witnesses shall not be present at the hearing when not testifying. No witness who refuses to be recorded may be permitted to give testimony. Written statements of witnesses under penalty of perjury shall not be admissible unless the witness is unavailable to testify. A witness who refuses to be tape recorded is not unavailable.

4.3.13 The hearing officer or hearing panel chair may determine that requiring live testimony of a proposed witness would subject the witness to an unreasonable risk of psychological or physical harm. After such a determination, the witness may be permitted to provide a written statement under penalty of perjury in lieu of testifying at the hearing.

4.3.14 The burden shall be on the District to introduce substantial evidence to support the charges against the student.

4.3.15 Within fifteen (15) days following the close of the hearing, the hearing officer or panel shall prepare and submit a written decision to the President. The decision shall include specific factual findings regarding the charges, conclusions as to the standards of student conduct that were violated, and a recommendation regarding the specific disciplinary action to be imposed, if any. Failure of the hearing officer or panel to submit its written decision within fifteen (15) days shall not invalidate the decision.

5.0 Procedures for Consideration of Expulsion by Board of Trustees

5.1 The Board shall hold closed sessions when it considers disciplinary action regarding expulsion of a student. The Board shall notify the student, and the parent if the student is a minor, by registered or certified mail or by personal service of the intent of the Board to call a closed session to consider the expulsion. The notification shall specify the date, time and place of the meeting at which the Board will consider the disciplinary action and shall be provided at least three (3) days prior to the meeting. Final action by the Governing Board may be taken in closed session, provided that the action of the Board shall be reported in public session. The student shall not be identified by name or other designation that would disclose the identity of the student.

5.2 In considering a recommendation for expulsion, the Board may accept, modify or reject the findings, decisions and recommendations of the President and/or the hearing officer or panel. If the Board modifies or rejects the decision of the President and/or the hearing officer or panel, the Board shall review the record of the formal hearing, and shall prepare a new written decision which contains specific factual findings and conclusions. The decision of the Board shall be final. The student, and the student's parent or guardian, if the student is a minor, shall be notified in writing of the Board's decision.

STUDENT RIGHTS AND RESPONSIBILITIES

The California Education Code provides that, "The board shall have the power to adopt such rules and regulations, not inconsistent with law, as are necessary for its own government and to enable the board to carry out all powers and responsibilities vested in it by law" (Section 71020). The Board of Trustees has prescribed the following rules relating to students. These rules shall apply to each of the colleges of the District. Each College President shall be responsible for the development of procedures required on that campus to assure that these rules are in effect on that campus.

1. ACADEMIC FREEDOM POLICY:

A college community, consisting of faculty, students, and administrators, under authority of the Board of Trustees, has as its primary purpose the realization of the students' growth and development through the dissemination and application of knowledge. Because it is only in the open exchange of ideas that this purpose can be achieved, students are encouraged to study any and all issues and problems. Freedom to think, read, question, and speak are necessary to the college community, but such freedoms must be exercised within the rules established under the general policies of the Board of Trustees.

2. STUDENT CLASSROOM RIGHTS AND RESPONSIBILITIES:

- a. Students enrolled in a course accept the instructor's authority in all matters pertaining to the classroom instruction and individual academic performance. Students have the right to:
 - (1) Know the instructor's standards for academic evaluation and classroom conduct.
 - (2) Challenge, with normal courtesy, faculty statements of opinion.
 - (3) Receive professional evaluation of their academic performance.
 - (4) Expect professional treatment of their views, beliefs, or political associations.
 - (5) Have reasonable access to members of the faculty on campus.
- b. Students enrolled in a course accept the responsibility to:
 - (1) Seek diligently to achieve the instructional objectives of the course.
 - (2) Practice honesty and respect the rights of others.
 - (3) Meet instructional and conduct standards as specified in 2.a.
- c. Students who violate the rights of other members of any class shall be subject to removal or suspension from that class.

3. CAMPUS RIGHTS AND RESPONSIBILITIES:

- a. Students have the right to:
 - (1) Participate in the formulation and application of college policy which affects them in accordance with procedures established on each campus under the general policies of the Board.
 - (2) Petition to organize interest groups pursuant to college and Board policies.
 - (3) Join student associations approved pursuant to college and Board policies.
 - (4) Invite and hear speakers as defined in the campus speakers policy.
- b. Students who violate the rights of chartered organizations shall be subject to the rules and regulations as published and distributed on each campus.
- c. Campus publications boards, or their equivalent, shall have the authority and responsibility for all college publications. Their authority and responsibility shall include, but not be limited to, providing written clarification of the role of student publications and the standards to be used in their evaluation. These standards shall be within the canons of responsible journalism and the limitations on control of their operations as established by the faculty advisor.

Title IX and Civil Rights Grievances

NORTH ORANGE COUNTY COMMUNITY COLLEGE DISTRICT NON-DISCRIMINATION STATEMENT

It is the policy of the North Orange County Community College District to provide an educational, employment, and business environment in which no person shall be unlawfully subjected to discrimination or sexual harassment, nor unlawfully denied full and equal access to the benefits of District programs or activities on the basis of ethnic group identification, national origin, religion, age, gender, race, color, ancestry, sexual orientation, marital status, or physical or mental disability as defined and prohibited by state and federal statutes. Any student who engages in unlawful discrimination or sexual harassment in violation of this policy will be subject to disciplinary action, which may include suspension or expulsion.

Students who believe they have been subjected to unlawful discrimination, including sexual harassment, or who seek information regarding the District's Unlawful Discrimination Policy, should contact the Office of the District Director of Human Resources at (714) 808-4818.

The following person is designated by the North Orange County Community College District as the Responsible Officer/Section 504 and Title IX Coordinator for receiving and coordinating the investigation of all unlawful discrimination complaints filed pursuant to section 59328 of Title 5 of the California Code of Regulations, and for coordinating compliance with section 504 of the Rehabilitation Act of 1973 and Title II of the Americans with Disabilities Act of 1990, Title IX of the Education Amendments of 1992, and response to discrimination complaints related thereto:

Name: Jeffrey O. Horsley
Position: Vice Chancellor, Human Resources
Address: 1830 W. Romneya Drive
Anaheim, CA 92801-1819
Telephone: (714) 808-4822

VICTIMS OF SEXUAL ASSAULT

Students who are victims of sexual assault occurring on District property or on an off-campus site or facility maintained by the District, or who seek information or assistance regarding a sexual assault, should contact the campus Director of Health Services at (714) 484-7045 or the Director of Campus Public Safety at (714) 484-7455. Except as may otherwise be required by law, all inquiries will be maintained in confidence.

AFIRMACIÓN SOBRE NO DISCRIMINACION

Las normas generales del North Orange County Community College District proveen un entorno educacional, laboral y comercial en el que ninguna persona es expuesta a la discriminación ni al acoso u hostigamiento sexual, como tampoco a ninguna vejación castigada por la ley, ni a negarle, contrario a la ley, acceso total y equitativo a los beneficios y actividades de los programas del Distrito, debido al grupo étnico al cual pertenece, nacionalidad de origen, religión, edad, género, raza, color, ancestros, inclinaciones sexuales, estado civil, o discapacidad física o mental, tal como lo definen y prohíben los estatutos estatales y federales. Todo estudiante que discrimine, acose u hostigue ilegalmente a otra persona, en contravención de las normas generales, quedará sujeto a que se tomen medidas disciplinarias contra esa persona, lo cual puede incluir suspensión o expulsión de este centro educacional.

Todo estudiante que crea ha sido objeto de discriminación ilícita, incluyendo acoso u hostigamiento, o que desee obtener información con respecto a las Normas Generales del Distrito sobre Discriminación Ilícita (District's Unlawful Discrimination Policy), debe comunicarse con la oficina del Director Distrital de Recursos Humanos (714) 808-4818.

La persona que mencionamos más adelante, ha sido designada por el North Orange County Community College District, como el Funcionario Responsable/Coordinador de la Sección 504/Derecho IX, ante quien se debe presentar la información para coordinar la investigación de todas las quejas de discriminación ilegal interpuestas, conforme a lo estipulado en la sección 59328 del Derecho 5 de las Reglamentaciones del Código de California, y para coordinar el acatamiento de la Sección 504 del Decreto de Rehabilitación de 1973 y del Derecho II del Decretote 1990 que ampara a los Americanos con Discapacidades, Derecho IX de las enmiendas de la educación de 1992, y responder a las quejas por discriminación relacionada:

Nombre: Jeffrey O. Horsley
Posición: Vice Chancellor, Human Resources
Dirección: 1830 W. Romneya Drive
Anaheim, CA 92801-1819
Teléfono: (714) 808-4822

VICTIMAS DEL ACOSO U HOSTIGAMIENTO SEXUAL

Aquellos estudiantes que sean víctimas de asalto sexual dentro del predio del Distrito o en algún sitio fuera del terreno o establecimiento universitario, bajo la responsabilidad del Distrito, o que busque información o ayuda con respecto a un asalto sexual, debe comunicarse con el Director de Servicios de Salubridad, llamando al teléfono: (714) 484-7045, o con el Director de la Seguridad Pública del Terreno Universitario, llamando al (714) 484-7455. Excepto como de alguna otra manera lo exija la ley, toda pregunta e información se mantendrá en la más estricta confidencialidad.

STUDENT RIGHT TO KNOW CAMPUS SECURITY ACT

In compliance with the Student Right-to-Know and Campus Security Act of 1990, it is the policy of the North Orange County Community College District and Cypress College to make available its completion and transfer rates to all current and prospective students. Beginning in Fall, 2004, all certificate-, degree-, and transfer-seeking first-time, full-time students were tracked over a three-year period; their completion and transfer rates are listed below. These rates do not represent the success rates of the entire student population at Cypress College, nor do they account for student outcomes occurring after this three-year tracking period.

Based upon the cohort defined above, 24% attained a certificate, degree or became "transfer prepared" during a three-year period (Fall, 2004, to Spring, 2007). Students who are "transfer-prepared" have completed 56 transferable units with a GPA of 2.0 or better.

Based upon the cohort defined above, 50% transferred to another post-secondary institution (CSU, UC, or another California Community College) prior to attaining a degree, certificate or becoming "transfer prepared" during a five-semester period (Spring, 2005 to Spring, 2007).

More detailed information related to the reporting of criminal actions which have occurred on campus may be obtained from the President's Office, Public Safety, Admissions and Records, Financial Aid, Bursar's Office, Student Activities, Library and the website.

Student Rights under FERPA for Postsecondary Institutions

FERPA at a Glance

THE FAMILY EDUCATIONAL RIGHTS AND PRIVACY ACT

What is FERPA?

The Family Educational Rights and Privacy Act of 1974, as amended, sets forth requirements regarding the privacy of student records. FERPA governs: (1) release of these records (known as education records) maintained by an educational institution and (2) access to these records. This law applies to K–12 as well as postsecondary education.

Who must comply with FERPA?

Any educational institution (school or other entity that provides educational services and is attended by students) and educational agency (entity that administers schools directly linked to it) that receives funds under any program administered by the U.S. Secretary of Education.

What does FERPA require for educational institutions to be in compliance?

- Notify students annually. Schools must notify students of their rights on an annual basis. There is no specific method that schools must use to notify students; it is up to the institution. Notice must take a form that is “reasonably likely” to notify students. Recommended and most frequently used ways include:
 - Student bulletin, handbook, or catalog
 - School or local newspaper
 - Student registration packet
- Protect students’ rights to inspect and review their education records.
- Protect students’ rights to request to amend their education records.
- Protect students’ rights to limit disclosure of personally identifiable information contained in education records.
- Ensure that third parties do not redisclose personally identifiable information (except under a few circumstances).
- Keep records of requests for and disclosures of student education records in limited situations.

Who has FERPA rights at the postsecondary level?

A student “in attendance” (regardless of age) and former students.

- *Student* applies to all students attending — including continuing education students, students auditing a class, distance education students, and high school students enrolled in college.
- In *attendance* applies to and is determined by the institution. If the institution has not defined when a student is “in attendance” that date becomes the day the student first attends a class at the institution.

What rights does FERPA provide for students?

- Right to inspect and review their education records.
- Right to request to amend their education records.
- Right to limit disclosure of some “personally identifiable information” (information that would directly identify the student or make the student’s identity easily traceable) known as *directory information*.

What is considered Directory Information?

Student’s name, major field of study, participation in officially recognized activities and sports, weight and height of members of athletic teams, dates of attendance, degrees and awards received, the most recent previous public or private school attended by the student, and any other information authorized in writing by the student. (NOCCCD BP 5040 effective April 2009).

The Family Educational Rights and Privacy Act (FERPA) affords students certain rights with respect to their education records. These rights include:

- (1) The right to inspect and review the student’s education records within 45 days of the day the College receives a request for access.

Students should submit to the registrar, dean, head of the academic department, or other appropriate official, written requests that identify the record(s) they wish to inspect. The College official will make arrangements for access and notify the student of the time and place where the records may be inspected. If the records are not maintained by the College official to whom the request was submitted, that official shall advise the student of the correct official to whom the request should be addressed.

- (2) The right to request the amendment of the student’s education record that the student believes is inaccurate.

Students may ask the College to amend a record that they believe is inaccurate. They should write the College official responsible for the record, clearly identify the part of the record they want changed, and specify why it is inaccurate.

If the College decides not to amend the record as requested by the student, the College will notify the student of the decision and advise the student of his or her right to a hearing regarding the request for amendment. Additional information regarding the hearing procedures will be provided to the student when notified of the right to a hearing.

- (3) The right to consent to disclosures of personally identifiable information contained in the student’s education records, except to the extent that FERPA authorizes disclosure without consent.

One exception, which permits disclosure without consent, is disclosure to school officials with legitimate educational interests. A school official is a person employed by the College in an administrative, supervisory, academic, research, or support staff position (including law enforcement unit personnel and health staff); a person or company with whom the College has contracted (such as an attorney, auditor, or collection agent); a person serving on the Board of Trustees; or a student serving on an official committee, such as a disciplinary or grievance committee, or assisting another school official in performing his or her tasks.

A school official has a legitimate educational interest if the official needs to review an education record in order to fulfill his or her professional responsibility.

Upon request, the College discloses education records without consent to officials of another school in which a student seeks or intends to enroll.

- (4) The right to file a complaint with the U.S. Department of Education concerning alleged failures by *the College* to comply with the requirements of FERPA. The name and address of the Office that administers FERPA is:

Family Policy Compliance Office
U.S. Department of Education
400 Maryland Avenue, SW
Washington, DC 20202-4605

Programs of Study

CERTIFICATE PROGRAMS

A program certificate is a verification of competency designed to make the student proficient and employable in a specific occupational skill. The certificate is awarded independently of the Associate Degree. Students who have maintained continuous enrollment have the option of completing the certificate requirements in effect at the time they initially enrolled or any subsequent catalog up to and including the last semester of attendance. At least 50% of all course work required for a Cypress College Certificate must be completed at Cypress College. All required courses must be completed with a minimum grade of "C." Students wishing to use courses from another institution to meet Cypress' requirements should meet with a counselor to review the necessary petitioning procedure. Program certificates will be noted on student transcripts.

HOW TO EARN A CERTIFICATE

Certificates do not require general education course work. Requirements for Certificate Programs for the 2012–2013 Catalog Year include:

- Submission of an Application for Certificate in the Admissions and Records Office.
- Completion of specific program courses listed in the catalog with a minimum grade of "C."
- Completion of at least 50% of the required courses at Cypress College.

Students may submit an application for multiple certificates per term providing requirements are met. A catalog academic year must be specified on the application. The catalog year will be used to determine if all certificate requirements have been met. **NOTE:** Specific course requirements for Certificates are listed in applicable sections of the catalog.

AIR CONDITIONING AND REFRIGERATION

Air Conditioning and Refrigeration
Air Conditioning Building Commissioning
Air Conditioning Codes and Estimating
Air Conditioning Commercial Air Conditioning
Air Conditioning Customer Service
Air Conditioning Environmental Controls
Air Conditioning Green Air Conditioning
Air Conditioning Heat Pumps
Commercial Refrigeration
Green Refrigeration

AIRLINE AND TRAVEL CAREERS

Advanced Airline Customer Services
Advanced Flight Attendant
Advanced Travel/Tourism
Basic Airline Customer Services
Basic Cruise Line Sales & Operations
Basic Flight Attendant
Basic Tourism & Conference Management
Basic Travel/Tourism
Homeland Transportation Security

ART

Animation 2D Computer Graphics
Animation 3D Computer Graphics
Computer Graphics
Electronic Publishing Design
Multimedia Art
Multimedia Advertising
Vector Illustration

AUTOMOTIVE

Auto Sales and Service
Automotive Collision Repair
Automotive Damage Appraisal
Automotive Paint and Refinishing
Automotive Sales and Service
Automotive Technology
Brake and Alignment Specialist
Electrical Diagnostic Specialist
Emission Control Specialist
Engine Specialist
Insurance Co/Auto Collision Repair Industry Management Skills
Maintenance Technician
Motorcycle Performance Technician
Performance and Driveability Specialist
Service Advisor
Toyota Specialist
Toyota Technician
Transmission Specialist

AVIATION

Aviation I — Private Pilot
Aviation II — Instrument Pilot
Aviation III — Commercial Pilot
Aviation IV — Advanced Pilot
Management

BUSINESS

Accounting
Management
Marketing
Merchandising
Professional Marketing
Retail Management

COMPUTER INFORMATION SYSTEMS

Advanced Networking
 Advanced Web Page Design
 Cisco Networking
 Computer and Office Applications
 Computer Applications
 Computer Forensics
 Computer Information Systems
 Computer Programming
 Computer Software and Application
 Game Programming
 Internet and Data Communications
 Microsoft Networking
 PC/Network Hardware Support
 Web Networking Technology
 Web Page Design

COURT REPORTING

CART* (Communication Access Realtime Translation)
 Computer Editor (Scopist)
 Court and Agency Services
 Court Reporting
 Legal Administrative Assistant

DANCE

Dance Teaching

DENTAL

Dental Assisting
 *Dental Hygiene

DIAGNOSTIC MEDICAL SONOGRAPHY

Diagnostic Medical Sonography

GEOGRAPHIC INFORMATION SYSTEMS

Geographic Information Systems
 Geographic Information Systems/Marketing

HEALTH INFORMATION

Health Information Coding
 *Health Information Technology
 *Medical Staff Services Management

HOTEL, RESTAURANT, CULINARY ARTS

Baking Fundamentals
 Baking and Pastry Arts
 Culinary Arts
 Culinary Fundamentals
 Dining Room Operations
 Food Service Management
 Hotel Operations
 Restaurant/Lodging Entrepreneur
 Rooms Operations
 Special Event Management

HUMAN SERVICES

Alcohol and Drug Studies
 Criminal Justice
 Conflict Resolution
 Family Studies Basic/Advanced
 Gerontology
 Human Services Generalist
 Victimology

MANAGEMENT

Business Economics
 Commercial Music — Management
 Management
 Retail Management
 Small Business Management

MARKETING

Automotive Sales and Service
 Geographic Information Systems/Marketing
 Marketing

MEDIA ARTS DESIGN

Animation 2D Computer Graphics
 Animation 3D Computer Graphics
 Computer Graphics
 Digital Cinema Arts & Industry
 Digital Cinema Production
 Digital Cinema Techniques & Technologies
 Electronic Publishing Design
 Multimedia Production Basics
 Post Production Basics for Cinema & Video
 Vector Illustration

MUSIC

Commercial Music Management
 Recording Arts

PHOTOGRAPHY

Advertising and Illustrative Photography
 Color Photography
 Creative Photo Arts
 Digital Photography
 Multimedia Photography
 Photography
 Portrait and Wedding Photography

PHYSICAL EDUCATION

Aerobic Instructor
 Aquatic Specialist
 Athletic Coach

PSYCHIATRIC TECHNOLOGY

Psychiatric Technology

RADIOLOGY

Darkroom Technician/Assistant
 *Radiology Technology

THEATER

Costume/Makeup Design
 Lighting/Audio Design
 Technical Theater

*Students must have previously earned an Associate Degree to be eligible for these certificates.

Students with disabilities requiring accommodations on state or national examinations should contact the department coordinator for further information. Requests for accommodations should be made prior to applying for any licensing or certification examination.

DEPARTMENT CERTIFICATES

Some departments offer certificates of accomplishment in specialty areas. Students should see a counselor for specific information about department certificate requirements.

APPLICATION FOR CERTIFICATES

Students may apply for a certificate during the semester they are completing the certificate requirements or thereafter. They do not have to be currently enrolled in Cypress College to apply for a certificate. Those students who have maintained continuous enrollment have the option of completing the certificate requirements in effect at the time they initially enrolled or any subsequent catalog up to and including the last semester of attendance. Students wishing to use courses from another institution to meet Cypress' requirements should meet with a counselor to determine course equivalency. Applications for certificates are available in the Admissions and Records Office and will be accepted until the deadline. If the application is not filed by the deadline, the student must submit another application and will receive the certificate at a later date. There is no fee for the certificate application. It is the student's responsibility to provide the Cypress College Records Office with official copies of all transcripts from other colleges that will be used to meet requirements for certificates. The transcripts become the property of the Admissions and Records Office and will not be released. Certificates will be mailed approximately two to three months after the end of the semester in which the student applied and completed the requirements. State approved Program Certificates will be noted on student transcripts.

Applications for a Certificate are available in the Admissions and Records office and online at www.CypressCollege.edu. Applications are due:

Semester	Date
Fall	Last day to add full term classes
Spring	Last day to add full term classes
Summer	Last day to add full term classes

ASSOCIATE DEGREES

Associate degrees are commonly conferred by community colleges. This degree is awarded upon a student's satisfactory completion of a program of study. Students who have maintained continuous enrollment have the option of completing the Associate Degree requirement in effect at the time they initially enrolled or any subsequent catalog up to and including the last semester of attendance. The Associate Degree is one of two types, the Associate in Arts or Associate in Science. The distinction between the degrees lies in the majors. An Associate in Arts Degree includes at least 18 units in Social Science, Humanities and Arts courses. An Associate in Science degree includes at least 18 units in Science, Math and Technical courses.

HOW TO EARN AN ASSOCIATE DEGREE

Graduation Requirements

For this catalog year

Graduation requirements for the Associate Degree are prescribed by the California Community Colleges Board of Governors, Title 5 and the North Orange County Community College District Board of Trustees. An Associate Degree may be earned upon satisfactory completion of all of the following:

1. General Education Requirements

All students are required to complete general education. Cypress College has three general education patterns:

- Cypress College general education pattern of 25 units.
- CSU General Education Breadth pattern of 39 units; or
- IGETC (Intersegmental General Education Transfer Curriculum) pattern of 37-39 units.

The appropriate pattern of general education for a specific degree is listed with the major requirements.

NOTE: A passing score on an Advanced Placement (AP) exam, College Level Exam Program (CLEP) exam, or International Baccalaureate (IB) exam may allow a student to receive subject credit for various general education requirements. Please reference the *External Exam Credit* policy section of the catalog for more specifics and see your counselor for questions regarding these policies.

2. Major/Area of Emphasis Requirement

A student must achieve a grade of "C" or better in each course attempted that is counted for the major or area of emphasis. Effective Fall 2008, C- (minus) grades do not satisfy these requirements. At least 50% of the major course work must be completed at Cypress College. (The Liberal Arts Areas of Emphasis in Arts and Humanities, Human Communication, Social and Behavioral Sciences, and Math and Science and the AA-T and AS-T are excluded from the 50% policy.) Each area of emphasis requires a minimum of 18 units. Liberal Arts Area of Emphasis: California community college courses taken to fulfill CSU GE/IGETC requirements may be used to satisfy a Cypress College Area of Emphasis Courses taken at other regionally accredited colleges and universities may also be considered to meet Liberal Arts Area of Emphasis requirements if they are deemed comparable to CSU GE/IGETC-approved courses.

3. Residence Requirement

Complete the last 12 units, or a total of at least 24 units, at Cypress College.

4. Scholarship Requirement

A cumulative grade-point average of 2.00 ("C") in all coursework attempted.

5. Elective courses

A student may complete additional degree-applicable classes for a total of 60 units (see Non-Degree Credit Courses for description of classes that are non-degree applicable).

Application for an Associate Degree

Although a student may have completed all requirements, an Associate Degree is not automatic. Students who intend to graduate must file an application with the Admissions and Records Office. Courses taken at other regionally accredited colleges and universities to fulfill General Education requirements may be used to satisfy Cypress College General Education requirements if they are comparable to Cypress College General Education courses or are used in the same category at the sending institution, and are degree applicable at Cypress College. (This policy supersedes all previous catalogs.) All official transcripts from other colleges are required at the time of application and become the property of the Admissions and Records Office and will not be released. Diplomas will be mailed approximately two to three months after the last day of the semester to the most recent address on file in the Admissions and Records Office at Cypress College. Applications for an Associate Degree are available in the Admissions and Records office and online at www.CypressCollege.edu. Applications are due:

Semester	Date
Fall	Last day to add full term classes
Spring	Last day to add full term classes
Summer	Last day to add full term classes

HONORS AT GRADUATION

In recognition of academic excellence for completion of the associate degree, students are awarded graduation honors as follows:

Honors	3.30–3.74
High Honors	3.75–4.00

Graduation honors are calculated using all degree applicable work completed. This includes coursework completed at Fullerton College and all other accredited institutions for which an official transcript has been received.

Graduation honors will be indicated in the commencement program and on the student's diploma and transcript. However, for candidates (those students with final grades pending), the commencement program will note "candidate" as their degrees and honors have not yet been confirmed. When final grades are posted, a recalculation of grades will be completed and, if the student qualifies, the graduation honor will be noted on the diploma and transcript.

Occupational Degree

The Occupational Degree is designed for individuals who desire an Associate in Arts or Associate in Science Degree with an occupational major. This degree may include transfer and/or non-transfer coursework (see Course Numbering section for description of transfer and non-transfer coursework) and includes completion of major requirements.

Requirements for the Occupational Degree include:

- Completion of 25 units of general education;
- Three (3) units of Cultural Diversity. These units must be chosen from the Cultural Diversity list;
- Completion of Reading Proficiency requirement;
- Completion of Major emphasis courses listed in the catalog with a minimum grade of "C." A minimum of 50% of these courses must be completed at Cypress College.

- Completion of additional degree-applicable classes for a total of 60 units (see Non-Degree Credit Courses for description of classes that are non-degree applicable).
- A 2.0 (C) overall GPA.

Occupational Degrees Offered by Cypress College are:

Accounting
 Administrative Assistant
 Administrative Support
 Air Conditioning and Refrigeration
 Airline Customer Services
 Art — General
 Art — Advertising Design
 Automotive Collision Repair
 Automotive Technology
 Aviation Management
 Commercial Pilot
 Computer Applications
 Computer and Office Applications
 Computer Information Systems
 Computer Programming
 Court Reporting
 Culinary Arts
 Dance
 Dental Hygiene
 Diagnostic Medical Sonography
 Drafting Engineering Technology
 Flight Attendant
 Food Service Management
 General Studies (Fine Arts emphasis)
 Health Information Technology
 Hotel Management
 Human Services
 Liberal Arts
 LVN to RN
 Management
 Marketing
 Medical Staff Services Science
 Merchandising
 Mortuary Science
 Music
 Photography
 Physical Education
 Pre-Engineering
 Psychiatric Technology
 PT to RN
 Radiologic Technology
 Registered Dental Assisting
 Registered Nursing
 Retail Management
 Small Business Management
 Theater Arts
 Travel/Tourism

General Studies Fine Arts

A.A. Degree

Program Code: 1A18452

The Associate of Art Degree in Fine Arts provides students with a scope of knowledge and broad overview for attaining the communication skills, practical knowledge, and training necessary for a variety of careers in the Fine Arts area. Students completing this degree will develop a basic understanding of the arts and how they interrelate. The Associate of Arts Degree in Fine Arts empowers the student to see Humanities, Math, Science, Engineering, Business and Career Technology through the prism of the arts. Key concepts in general education are reinforced by their connection to the arts. Bridging the wisdom of the ages with contemporary innovations, this program offers a well rounded education with insight to opportunities in our modern world.

Requirements for the General Studies Degree in Fine Arts include:

- Completion of 25 units of general education;
- Three (3) units of Cultural Diversity. These units must be chosen from the Cultural Diversity list;
- Completion of Reading Proficiency requirement;
- Completion of at least 18 units. (Note: Where appropriate, courses may also be counted for a GE area). At least 50% of all course work must be completed at Cypress College;
- Completion of additional degree-applicable classes for a total of 60 units (see Non-Degree Credit Courses for description of classes that are non-degree applicable);
- A 2.0 (C) overall GPA and a 2.0 (C) in all courses taken in the Area of Emphasis.

General Education Requirements for the Associate Degree

General Education requirements at Cypress College are designed to introduce students to the many ways people comprehend the modern world. The subject matter presented in general education courses is designed to be broad, and frequently introductory, rather than specialized, narrow, or advanced. These courses form a pattern of learning experiences designed to develop the following insights and capacities in all students, regardless of their ultimate educational goals:

- Knowledge of the common principles, concepts, and modes of inquiry in the major disciplines;
- Appreciation and understanding of the environment, culture, society, and self;
- Ability to think and communicate clearly and effectively, critically and ethically both orally and in writing;
- Proficiency in mathematics, natural science, and analytical thinking;
- Understanding of the political and economic environment in order to be better informed and more responsible citizens;
- Desire to continue education throughout their lives.

Courses taken for general education must be on the Associate Degree General Education list at the time they are taken. Continuing students should check with a counselor in planning completion of General Education requirements. Students entering Cypress College in Fall 1995, or later, must complete 25 units of General Education (of the total 60 degree applicable units required for the Associate Degree) taken from the following areas listed on the next page.

Note: A satisfactory score on the Cypress College reading proficiency test will determine placement into college-level English (**Area A1 below**) or pre-college level coursework. Refer to the Class Schedule listed under STEP TWO, ENGLISH ASSESSMENT. A student may attempt to pass the proficiency exam only one time after completion of English 100 C or equivalent.

The mathematics requirement may be met by passing a Mathematics Proficiency Examination (**Area B2 below**). Refer to the Class Schedule for time and date of administration of the Mathematics Proficiency Examination. See Math Proficiency Examination explanation, location can be found in the MATHEMATICS portion of the Class Schedule or the catalog.

CYPRESS COLLEGE

CYPRESS COLLEGE GENERAL EDUCATION REQUIREMENTS FOR THE AA/AS DEGREE

Associate Degree Requirements: Includes fulfillment of both the cultural diversity and reading requirements, major course-work toward an occupational degree (AA or AS), completion of 60 degree eligible units with a minimum grade point average of 2.0 and satisfaction of the 25-unit general education requirement as described in the following list. Courses taken for general education must be on the AA degree General Education list at the time they are taken. Students should check with their counselor in planning completion of General Education requirements.

CATEGORY A. LANGUAGE AND RATIONALITY 6-UNIT MINIMUM

A1. WRITTEN COMMUNICATION: 3 Unit Minimum

ENGL 100C[□] (100HC[□])

A2. ANALYTICAL THINKING: 3 Unit Minimum

COMM 050C, 100C[□] (100HC[□]), 135C; CIS 111C; CSCI 185C; ENGL 075C, 103C, 104C[□] (104HC[□]) 106C*, 135C, 201C; PHIL 170C, 172C

CATEGORY B. NATURAL SCIENCES AND MATHEMATICS

6-UNIT MINIMUM

B1. LIFE SCIENCES AND PHYSICAL SCIENCES: 3 Unit Minimum

ANTH 101C[□] (101HC[□]), 101LC, 201C; ASTR 116C[□]/117C[□] (116HC[□]/117HC[□]); BIOL 101C[□] (101HC[□]), 102C, 103C, 107C, 111C/112C, 113C/114C, 122C, 127C, 128C, 160C, 210C, 230C, 231C(begin F06), 241C(begin F06); CHEM 100C, 101C, 103C[□] (103HC[□]), 104C[□], 107C, 111AC, 111BC; GEOG 102C/102LC; GEOL 100C[□]/101C (100HC[□])/101C, 100C[□]/115C (100HC[□])/115C, 102C, 103C, 105C, 120C, 125C, 130C/131C, 190C; PHSC 104C[□]; PHYS 130C, 201C, 210C, 211C, 221C

B2. MATHEMATICS: 3 Unit Minimum***

MATH 030C(begin F09), 038C, 040C, 100C, 105C, 110C, 115C, 120C[□] (120HC[□]), 130C, 141C, 142C, 150AC, 150BC, 250AC, 250BC; MGT 151C; PSY 161C[□]; SOC 161C[□]

CATEGORY C. ARTS AND HUMANITIES

6-UNIT MINIMUM

C1. ARTS: 3 Unit Minimum

ART 100C, 110C, 111C, 112C[□] (112HC[□]), 114C, 115C[°], 120C, 150C, 151C, 182C[°], 185C[°], 188C[°], 189C[°], 216C; DANC 100C, 101C**, 105C[°], 106C[°], 107C[°], 108C[°], 111C[°], 112C[°], 120C, 134C; ENGL 125C[□] (125HC[□]); MMPH 101C[□]; MUS 101C, 103AC, 113C**, 115C, 116C, 117C, 118C[°] (118HC[□]), 119C, 120C, 122C^{°°}, 127C, 135C, 171C, 274C^{°°°}, 280C^{°°°}, 282C^{°°°}, 291C^{°°}; PHOT 101C[□]; SPCH 115C; THEA 100C, 102C[□] (102HC[□]), 104C[°], 107C^{**□} (107HC^{**□}), 108C^{°°}, 120C[°], 126C[°], 129C[°], 132C^{°°}, 133C^{°°}, 149C^{°°}

C2. HUMANITIES: 3 Unit Minimum

CHIN 100C, 101C, 102C; COMM 220C^{□◇} (220HC^{□◇}); ENGL 097C**, 102C^{*□} (102HC^{*□}), 110C[□], 111C[□], 115C, 126C, 207C, 208C, 211C, 212C, 221C, 222C, 234C[□] (234HC[□]), 239C**, 247C**, 254C, 255C**, 256C**; FREN 101C, 102C, 203C, 204C; GERM 101C, 102C; INDS 100C[□], 101C[□]; JAPN 100C[°], 101C, 102C, 125C, 203C, 204C; JOUR 110C; PHIL 100C[□] (100HC[□]), 101C, 110C, 120C, 160C, 201C, 202C, 230C; PORT 101C, 102C; SPAN 101C[□] (101HC[□]), 102C[□] (102HC[□]), 201C, 202C, 203C, 204C

(Continues on next page)

CATEGORY D. SOCIAL SCIENCES	6-UNIT MINIMUM
<p>ANTH 102C[□] (102HC[□]), 106C, 103C (formerly 203C); COMM 220C[◇] (220HC[◇]); ECON 100C[□] (100HC[□]), 105C[□] (105HC[□]), 110C; ETHS 101C[□] (formerly 100C)(101HC[□])(formerly 100HC), 129C^{**}, 130C^{**}, 131C^{**}, <u>140C^{**}</u>, <u>141C^{**}</u>, 150C^{**}, 151C^{**}, 152C^{**}, 160C^{**}, 170C^{**}, 171C^{**}; GEOG 100C[□] (100HC[□]), 160C; HIST 110C[□] (110HC[□]), 111C[□] (111HC[□]), 112C[□] (112HC[□]), 113C[□] (113HC[□]), 135C, 142C(<u>begin F05</u>), 143C, 160C, 161C, 162AC, 162BC, 163C(<u>begin F05</u>), 165C, 170C[□] (170HC[□]), 171C[□] (171HC[□]), 270C(<u>begin F05</u>); HS 277C^{**}; HUSR 250C[□] (<u>begin F06</u>), 255C[□] (<u>begin F06</u>); MGT 161C, 266C; POSC 100C[□] (100HC[□]), 101C, 120C, 200C, 210C, 215C, 230C; PSY 101C[□] (101HC[□]), 120C(<u>begin F08</u>), 145C, 240C(<u>begin F05</u>), 251C, 255C[□] (<u>begin F06</u>); SOC 101C[□] (101HC[□]), 102C, 120C(<u>begin F08</u>), 250C[□] (<u>begin F06</u>), <u>271C</u>, 275C</p>	
CATEGORY E. PHYSICAL ACTIVITY AND HEALTH	1-UNIT MINIMUM
<p>HRC 100C; PE 83C thru 222C^{°°}, 234C, 244C</p>	
CULTURAL DIVERSITY	3-UNIT MINIMUM
<p>ATC 182 C; ANTH 121C; COMM 120C; COUN <u>152C</u>; DANC 101C; ENGL 097C, 208C, 239C, 247C, 255C, 256C ETHS 101C[□] (formerly 100C)(101HC[□])(formerly 100HC), 129C, 130C, 131C, <u>140C</u>, <u>141C</u>, <u>142C</u>, 150C, 151C, <u>152C</u>, 153C, 160C, 170C, 171C, 235C; HIST 275C; HS 277C; HUSR 295C; MKT 205C; MUS 113C(<u>begin F05</u>); PE 250C; POSC 209C; PSY 237C; SOC <u>235C</u>, 237C; THEA 107C[□] (107HC[□])</p> <p>Completion of the Nursing Program also meets the Cultural Diversity graduation requirement.</p>	
READING PROFICIENCY REQUIREMENT	
<p>One of the following:</p> <p>ENGL 96C, 102C, 106C; A satisfactory score on the Cypress College Reading Proficiency Test; Completion of CSU GE Certification, IGETC Certification, or a Bachelor Degree from a U.S. regionally accredited institution. Specific External Exam Credit may satisfy the requirement (see a counselor for details).</p>	
LEGEND	
<p>* Also meets Reading Proficiency requirement for graduation.</p> <p>** Also meets Cultural Diversity requirement for graduation.</p> <p>*** The Mathematics requirement can also be met by passing a Mathematics Proficiency Examination. Refer to the Schedule of Classes for time and date of administration of the examination.</p> <p>◇ Course may be used to satisfy requirements for one area only.</p> <p>□ Duplicate credit not granted for the same honors and non-honors classes or for the same course listed in two different disciplines.</p> <p>° May be taken one (1) time for GE credit.</p> <p>°° May be taken two (2) times for GE credit.</p> <p>°°° May be taken three (3) times for GE credit.</p>	
<p>NOTE: Underlining indicates a course is no longer offered at Cypress College. Students may still receive credit as long as a course was on the official approved list in that category at the time it was taken.</p>	

REMINDER: In order to receive General Education credit, the course must be on the official approved list at the time the course is taken.

Please confer with a counselor for more information.

Associate Degree Graduation Requirements for Cypress College

NOTE: The following graduation requirements apply to all degrees with the exception of the Associate Degrees for Transfer (AD-T) for priority admission to CSU. The list of available AD-T degrees also known as Associate in Art (AA-T) degrees or Associate in Science (AS-T) degrees are listed both in the catalog and on the Transfer Center website: <http://www.CypressCollege.edu/services/transfer>.

Cultural Diversity

As an educational community, Cypress College embraces the shared characteristics as well as the diverse intellectual viewpoints and ideas of its culturally rich population. To prepare students for effective participation in our society, selected academic courses are designed to: 1) foster respect for diverse populations; 2) assist students in understanding and critically evaluating personal biases; and 3) encourage students to apply the knowledge gained in these courses in their daily lives. To achieve this educational goal, Cypress College will require all students to take at least one course whose emphasis is on the United States and focuses specifically on issues such as race, gender, religion, national origin, sexual orientation, socio-economic background, physical and/or mental ability, and how they impact the struggles of people to achieve civil and human rights.

Please reference the list of approved Cultural Diversity courses for the college on the general education list for the Associate Degree.

Reading Proficiency

Proficiency in reading may be satisfied by completing one of the following:

- ENGL 096 C College Reading Strategies
- ENGL 102 C Introduction to Literature
- ENGL 102HC Honors Introduction to Literature
- ENGL 106 C Critical Thinking
- A satisfactory score on the Cypress College reading proficiency test. (Contact the Language Arts division office at (714) 484-7000 ext. 48571 for information regarding the Reading Proficiency Exam.)
A student may attempt to pass the proficiency exam only one time after completion of English 100 C or equivalent.
- California State University (CSU) general education certification.
- IGETC certification.
- Bachelor's degree from a regionally accredited institution.
 - Passing score of 3 or higher on the Advanced Placement (AP) English Literature exam
 - Nursing program

TRANSFER PROGRAMS

Transfer programs include course work in an academic area, general education requirements, and elective work for transfer to a four year baccalaureate institution. Transfer programs are designed to parallel the courses offered for freshmen and sophomores at other colleges and universities. In most cases, baccalaureate institutions prefer community college students to complete the lower division general education requirements and at least 60 or more transferable semester units. Generally, no more than 70 semester units earned at California community colleges will be applied toward a baccalaureate degree.

HOW TO TRANSFER TO A FOUR-YEAR COLLEGE

Each college or university has its own admission standards and curriculum requirements. Students should decide as soon as possible on the transfer school in order to identify the courses that must be completed and the grades that must be achieved prior to transfer. In general, students who attend Cypress College may transfer to a four-year college or university without loss of time or credits if, while in attendance, they accomplish the following:

- Satisfy the lower-division general education requirements prescribed by the transfer institution.
- Fulfill the lower-division major requirements prescribed by the transfer institution.
- Remove any subject or grade deficiencies incurred in high school, if required by the transfer institution for admission.
- Complete a minimum of 60 and a maximum of 70 transferable units.
- Maintain the appropriate GPA required by the transfer institution.

Grades are the best indicator of success in academic work. A minimum grade of "C" average in all transfer courses is a requirement for transfer to most four-year colleges. Grades in the major should be significantly higher. Students should confer with a counselor for the specific requirements of the school of their choice. The following charts indicate the general education transfer requirements for those colleges and universities most frequently utilized by Cypress College students. These transfer agreements are subject to an ongoing review and revision by the transfer institutions. The transfer agreements listed on the following charts represent agreements at the time of publication. Students should contact a counselor or the transfer institution of their choice for current information.

Liberal Arts Degree with Area of Emphasis

The Liberal Arts degree with Area of Emphasis provides students with the opportunity to earn a degree within a broad liberal arts education, allowing them to understand the intellectual relationships between various disciplines in a broader Area of Emphasis. Earning an Associate Degree may or may not be the most effective path to fulfilling transfer requirements. The courses listed for each Area of Emphasis in the Cypress College catalog do not reflect major preparation requirements at any specific university, but some may be used to fulfill local university requirements. **Please consult with a counselor and the Transfer Center for information regarding selection of an appropriate general education pattern and pertinent classes, as well as your intended major at the specific colleges/universities of choice.**

NOTE: This degree is an Associate Degree designed for transfer students; however, it does not qualify as an Associate Degree for Transfer (AD-T) for CSU priority admission consideration. Please see a counselor for more information on differences in degree options offered at Cypress College for transfer students.

Requirements for the Liberal Arts Degree with Area of Emphasis include:

- Completion of California State University General Education Breadth requirements (CSU GE Breadth) or the Intersegmental General Education Transfer Curriculum (IGETC).
- Completion of at least 18 units in an Area of Emphasis from those outlined below. (Note: Where appropriate, courses in the Area of Emphasis may also be counted for a GE area.)
- A 2.0 (C) overall GPA and a 2.0 (C) in all courses taken in the Area of Emphasis.
- **Fulfillment of all graduation requirements, to include one (1) unit of physical education and three (3) units of Cultural Diversity for a total of 60 transferable units.**

Note: Completion of this Area of Emphasis degree option automatically meets the Reading Proficiency requirement.

Liberal Arts AA Degree with Area of Emphasis ARTS & HUMANITIES emphasis

Liberal Arts AA Degree: ARTS & HUMANITIES emphasis

The Arts & Humanities option under Liberal Arts is an ideal choice for students planning on transferring to the California State University (CSU) or University of California (UC). Students are able to satisfy both their transfer institution's general education requirements, plus focus on transfer major preparation course work required by the four-year university. The Area of Emphasis listed below includes courses that transfer to CSU and/or UC. Courses in BOLD are transferable to UC. Refer to www.ASSIST.org for further details.

This degree emphasizes the study of cultural, literary, humanistic activities and artistic expression of human beings. Students will evaluate and interpret the ways in which people through the ages in different cultures have responded to themselves and the world around them in artistic and cultural creation. Students will also learn to value aesthetic understanding and incorporate these concepts when constructing value judgments.

Select 18 or more units from at least 2 discipline areas:

ART 100 C, 110 C, 111 C, 112 C, (112 HC), 114 C, 120 C, 150 C, 151 C, 182 C, 189 C, 216 C(begin F11)

CHIN 101 C, 102 C

COMM 220 C, (220HC)

DANC 101 C, 120 C

ENGL 102 C, (102HC), 110 C, 111 C, 125 C, (125HC), 208 C, 211 C, 212 C, 221 C, 222 C, 234 C, (234HC), 239 C, 247 C, 255 C, 256 C

ETHS 130 C, 131 C, 151 C (Formerly 141 C), 152 C, 160 C, 171 C

FREN 101 C, 102 C, 200 C, 203 C, 204 C

HIST 110 C, (110 HC), 111 C, (111HC), 112 C, (112 HC), 113 C,(113HC), 160 C (Formerly 160AC), 161 C (Formerly 160BC), 163 C, 165 C, 275 C

INDS 100 C, 101 C

JAPN 101 C, 102 C, 125 C, 200 C, 203 C, 204 C

MUS 101 C, 103AC, 113 C, 116 C, 117 C, 118 C, (118HC), 119 C, 120 C, 122 C, 126 C, 127 C, 130 C, 135 C, 143 C, 146 C, 282 C

PHOT 101 C

PHIL 100 C, (100HC), 101 C, 110 C, 120 C, 135 C, 160 C, 201 C, 202 C, 240 C (Formerly 225 C), 230C

PORT 101 C, 102 C

SPAN 101 C, (101HC), 102 C,(102 HC), 200 C, 201 C, 202 C, 203 C, 204 C

THEA 100 C, 107 C, (107HC), 120 C, 121 C, 126 C, 129 C, 132 C, 133 C, 145 C, 149 C

Special note: This degree is an Associate Degree designed for transfer students; however, it does not qualify as an Associate Degree for Transfer (ADT) for CSU priority admission consideration. Please see a counselor for more information on differences in degree options offered at Cypress College for transfer students.

**Liberal Arts AA Degree with Area of Emphasis
HUMAN COMMUNICATION emphasis**

<u>Liberal Arts AA Degree: HUMAN COMMUNICATION emphasis</u>
<p>The Human Communication option under Liberal Arts is an ideal choice for students planning on transferring to the California State University (CSU) or University of California (UC). Students are able to satisfy both their transfer institution's general education requirements, plus focus on the transfer major preparation course work required by the four-year university. The Area of Emphasis listed below includes courses that transfer to CSU and/or UC. Courses in BOLD are transferable to UC. Refer to www.ASSIST.org for further details.</p> <p>This degree emphasizes the content of communication as well as the form and should provide an understanding of the psychological basis and social significance of communication. Students will be able to assess communication as the process of human symbolic interaction. Students will also develop skills in the areas of reasoning and advocacy, organization, accuracy, reading and listening effectively. Students will be able to integrate important concepts of critical thinking as related to the development of analysis, critical evaluation, to reason inductively and deductively that will enable them to make important decisions regarding their own lives and society at large.</p>
Select 18 or more units from at least 2 discipline areas:
COMM 100 C, (100HC), 135 C, 138 C, 238 C
ENGL 100 C, (100HC), 103 C, 104 C, (104HC), 106 C
PHIL 170 C, 172 C, 175 C

Special note: This degree is an Associate Degree designed for transfer students; however, it does not qualify as an Associate Degree for Transfer (AD-T) for CSU priority admission consideration. Please see a counselor for more information on differences in degree options offered at Cypress College for transfer students.

**Liberal Arts AA Degree with Area of Emphasis
SOCIAL & BEHAVIORAL SCIENCES emphasis**

<u>Liberal Arts AA Degree: SOCIAL & BEHAVIORAL SCIENCES emphasis</u>
<p>The Social & Behavioral Sciences option under Liberal Arts is an ideal choice for students planning on transferring to the California State University (CSU) or University of California (UC). Students are able to satisfy both their transfer major preparation course work. The Area of Emphasis listed below includes courses that transfer to CSU and/or UC. Courses in BOLD are transferable to UC. Refer to www.ASSIST.org for further details.</p> <p>This degree emphasizes the perspective, concepts, theories and methodologies of the disciplines typically found in the vast variety of disciplines that comprise study in the Social and Behavioral Sciences. Students will study about themselves and others as members of a larger society. Topics and discussion to stimulate critical thinking about ways people have acted in response to their societies will allow students to evaluate how societies and social subgroups operate.</p>
SELECT 18 OR MORE UNITS FROM AT LEAST 2 DISCIPLINE AREAS:
ANTH 102 C, (102HC), 104 C, 105 C, 106 C, 107 C, 121 C, 103 C (Formerly 203 C), 225 C
COMM 120 C
ECON 100 C, (100HC), 105 C, (105HC), 110 C, 260 C
ETHS 101 C (Formerly 100 C), (101HC) (Formerly 100HC), 129 C, 130 C, 131 C, 150C (Formerly 140 C), 151 C (Formerly 141 C), 152 C, 153 C, 160 C, 170 C, 171 C, 235 C
GEOG 100 C, (100HC), 130 C, 140 C, 160 C, 260 C
HS 277 C
HIST 110 C, (110HC), 111 C, (111HC), 112 C, (112HC), 113 C, (113HC), 135 C, 142 C, 143 C, 151 C, 152 C, 160 C, 161 C, 162AC, 162BC, 163 C, 165 C, 170 C, (170HC), 171 C, (171HC), 270 C, 275 C
HUSR 200 C, 250 C, 255 C, 292 C
JOUR 110 C, 118 C
MGT 161 C
POSC 100 C, (100HC), 101 C, 120 C, 130 C, 200 C, 209 C, 210 C, 215 C, 216 C, 230 C
PSY 101 C, (101HC), 110 C, 120 C, 139 C, 145 C, 202 C, 221 C, 222 C, 237 C, 240 C, 251 C, 255 C
SOC 101 C, (101HC), 102 C, 120 C, 225 C, 237 C, 250 C, 271 C, 275 C, 277 C, 292 C

Special note: This degree is an Associate Degree designed for transfer students; however, it does not qualify as an Associate Degree for Transfer (AD-T) for CSU priority admission consideration. Please see a counselor for more information on differences in degree options offered at Cypress College for transfer students.

**Liberal Arts AA Degree with Area of Emphasis
MATH & SCIENCE emphasis**

Liberal Arts AA Degree: MATH & SCIENCE emphasis

The Math & Science option under Liberal Arts is an ideal choice for students planning on transferring to the California State University (CSU) or University of California (UC). Students are able to satisfy both their transfer institution's general education requirements, plus focus on transfer major preparation course work required by the four-year university. The Area of Emphasis listed below includes courses that transfer to CSU and/or UC. Courses in BOLD are transferable to UC. Refer to www.ASSIST.org for further details.

This degree emphasizes the natural sciences which examine the physical universe, its life forms, and its natural phenomena. Courses in Math emphasize the development of mathematical and quantitative reasoning skills beyond the level of intermediate algebra. Students will be able to demonstrate an understanding of the methodologies of science as investigative tools. Students will also examine the influence that the acquisition of scientific knowledge has on the development of the world's civilization. Students will also examine the influence that the acquisition of scientific knowledge has on the developmental of the world's civilizations.

SELECT 18 OR MORE UNITS FROM AT LEAST 2 DISCIPLINE AREAS:

ANTH 101 C, (101HC), 101LC

ASTR 116 C, (116HC), 117 C, (117HC)

BIOL 101 C, (101HC), 102 C, 103 C, 111 C, 112 C, 113 C, 114 C, 122 C, 210 C, 231 C, 241 C

CHEM 100 C, 101 C, 103 C, 104 C, 107 C, 111AC, 111BC

CSCI 205 C

GEOG 102 C, 102LC

GEOL 100 C, (100HC), 101 C, 103 C, 105 C, 115 C, 120 C, 125 C, 130 C, 131 C, 190 C

MATH 100 C, 115 C, 120 C, 130 C, 141 C, 142 C, 150AC, 150BC, 250AC, 250BC

PHSC 104 C

PHYS 130 C, 201 C, 202 C, 210 C, 211 C, 221 C, 222C, 223 C

PSY 161 C

SOC 161 C

Special note: This degree is an Associate Degree designed for transfer students; however, it does not qualify as an Associate Degree for Transfer (AD-T) for CSU priority admission consideration. Please see a counselor for more information on differences in degree options offered at Cypress College for transfer students.

Liberal Arts Degree with a Specified Department/Area Major

The Liberal Arts degree with Departmental/Area Major provides students with the opportunity to earn a degree within a broad liberal arts education, allowing them to understand the intellectual relationships between various disciplines with a more specific focus in a Departmental/Area Major. Earning an Associate Degree may or may not be the most effective path to fulfilling transfer requirements. The courses listed for each Departmental/Area Major in the Cypress College catalog do not reflect major preparation requirements at any specific university, but some may be used to fulfill local university requirements. Students pursuing more than one specified departmental major may double count a maximum of 7 units to fulfill major requirements. **Please consult with a counselor and the Transfer Center for information regarding selection of an appropriate general education pattern and pertinent classes, as well as your intended major at the specific colleges/universities of choice.**

NOTE: This degree is an Associate Degree designed for transfer students; however, it does not qualify as an Associate Degree for Transfer (AD-T) for CSU priority admission consideration. Please see a counselor for more information on differences in degree options offered at Cypress College for transfer students.

Requirements for the Liberal Arts Degree with a Specified Departmental/Area Major include:

- Completion of the California State University General Education Breadth requirements (CSU GE Breadth) or the Intersegmental General Education Transfer Curriculum (IGETC).
- Completion of at least 18 units in one Departmental/Area Major from those outlined below. (Note: Where appropriate, courses in the Departmental/Area Major may also be counted for a GE area.) At least 50% of all major course work must be completed at Cypress College;
- A 2.0 (C) overall GPA and a 2.0 (C) in all courses taken in the Departmental/Area Major;
- Fulfillment of all graduation requirements, to include one (1) unit of physical education and three (3) units of Cultural Diversity for a total of 60 transferable units.

Note: Completion of this option automatically meets the Reading Proficiency requirement.

This degree includes only transfer-level coursework; however, students who select a Departmental/Area Major, and intend to earn a Bachelor's Degree should consult with a counselor to ensure optimal application of credit toward the Bachelor's Degree requirements. Completion of major preparation requirements as determined by the receiving UC or

CSU campus are officially listed on the Assist website at www.assist.org.

NOTE: Specific course requirements for Departmental/Area Majors are listed in applicable sections of the catalog.

Departmental/Area Majors Offered by Cypress College are:

African American Studies (see Ethnic Studies)
 Anthropology
 Business
 Chicana/o Studies (see Ethnic Studies)
 Geography
 Ethnic Studies
 Philosophy

Associate Degrees for Transfer (Associate in Arts/Associate in Science Degree for Transfer) (AD-T)

California Community Colleges are now offering associate degrees for transfer (AD-T) to the CSU. These may include Associate in Arts (AA-T) or Associate in Science (AS-T) degrees. These degrees are designed to provide a clear pathway to a CSU major and baccalaureate degree. California Community College students who are awarded an AD-T degree are guaranteed admission with junior standing somewhere in the CSU system and given priority admission consideration to their local CSU campus or to a program that is deemed similar to their community college major. This priority does not guarantee admission to specific majors or campuses.

The AD-T degree is intended for students who plan to complete a bachelor's degree in a similar major at a CSU campus. Students who have been awarded an AD-T are able to complete their remaining requirements for the 120-unit baccalaureate degree within 60 semester or 90 quarter units (unless the major is designated "high-unit" major). To view the most current list of Cypress College Associate Degrees for Transfer and to find out which CSU campuses accept each degree, please go to www.CypressCollege.edu/services/transfer. This degree may not be the best option for students intending to transfer to a particular CSU campus or to a university or college that is not part of the CSU system.

Current and prospective community college students are encouraged to meet with a counselor to review their options and learn how to develop an educational plan that best meets their goals and needs as it relates to university admission and transfer requirements.

Requirements for the Associate Degree for Transfer (AD-T) include:

- Completion of the California State University General Education Breadth requirements (CSU GE Breadth) or the Intersegmental General Education Transfer Curriculum (IGETC).
- Completion of at least 18 units in one AA-T or AS-T Major from those outlined below. (Note: Where appropriate, courses in the AA-T or AS-T Major may also be counted for a GE area).
- A 2.0 (C) overall GPA and a 2.0 (C) in all courses taken in the AA-T or AS-T Major.
- Completion of a minimum of 60 units of CSU transferable coursework.

This degree includes only transfer-level coursework; however, students who select an AA-T or AS-T and intend to earn a Bachelor's Degree should consult with a counselor to ensure optimal application of credit toward the Bachelor's Degree requirements. Completion of major

preparation requirements as determined by the receiving UC or CSU campus are officially listed on the Assist website at www.assist.org.

NOTE: Specific course requirements for the AA-T and AS-T Majors are listed in applicable sections of the catalog.

AA-T or AS-T Majors Offered by Cypress College are:

Business Administration
 Communication Studies
 History
 Psychology
 Sociology

CSU GENERAL EDUCATION BREADTH REQUIREMENTS

Students wishing to transfer to California State Universities should follow this plan.

Requirements for graduation from the California State University System include completion of specific courses in general education. Cypress College is permitted to certify that a student has satisfied the lower division 39-unit general education requirements established by the California State University System.

Under the provisions of Title 5 and Executive Order 595, regionally accredited colleges and universities may certify one or more subject areas for students being admitted to the CSU system, a.k.a. partial certification. Students admitted to a CSU campus with subject area or partial certification should not be held to completing additional courses for the areas already certified.

In order to be partially certified, Cypress College students must complete all the CSU lower-division General Education Breadth Requirements in a specific area. Students who have completed courses at other regionally-accredited colleges and universities may "pass along" those courses for either partial or full certification at Cypress College. To meet general education requirements and obtain full certification, students must complete the pattern of courses in the five categories listed.

Students should apply for certification during or after the semester in which they are completing General Education Breadth Requirements. Students are advised to request certification prior to enrolling at the university due to varying CSU campus partial certification policies that may prohibit the certification from being granted.

CSU Certification policy specifies that a course or sequence of courses used to satisfy a requirement in one area, may not be used to satisfy a requirement in another area. Students should talk to a counselor for more information. Some state universities will also not allow students to count courses in their major field as part of general education requirements.

Courses on this list are approved by the CSU Chancellor's Office for a specific academic year; that is, a course must be on the list when the course is taken in order to be certified. Check with a counselor and review the catalog of the individual state university for further clarification.

A pass along form must be completed by a Cypress College counselor when courses are being used from other non-certifying colleges and universities and submitted with the application for CSU General Education Certification. No deadlines apply for the CSU GE Breadth pattern.

CALIFORNIA STATE UNIVERSITY LOWER DIVISION GENERAL EDUCATION REQUIREMENTS

39 Units Required

Certification of General Education Requirements for CSU: Students planning to graduate from one of the campuses of the California State University must complete a minimum of 48 semester units in General Education breadth courses. Cypress College is permitted to certify completion of the lower division 39-unit general education requirement. (A minimum of 9 units of General Education coursework must be completed at the upper division level after transfer. To meet general education requirements and obtain certification, students must complete the pattern of courses in the categories listed. Please see the current catalog for additional information on CSU-GE Partial Certification.) Certification is not automatic. Students must apply for GE certification through the Admissions and Records Office by the published deadline during the semester in which requirements will be completed or thereafter. The course must be on the list when it is taken in order to be certified. This list has some courses that are valid only for certain years, students should refer to the legend below or the Cypress College CSU GE-Breadth Certification List on www.assist.org to verify that a course was valid when it was taken. A course or sequence of courses used to satisfy a requirement in one area may not be used to satisfy a requirement in another area. Some universities will not allow students to count courses in their major field as part of general education. Check with a counselor and review the university catalog for further clarification.

A. ENGLISH LANGUAGE COMMUNICATION AND CRITICAL THINKING	9 Unit Minimum
<i>Requirement: Must include a minimum of 3-units from each area. All courses in this category must be completed with a grade of "C" or better.</i>	
A1.Oral Communication: COMM 100C[□] (100HC[□]) A2.Written Communication: ENGL 100C[□] (100HC[□]) A3.Critical Thinking: COMM 135C, 138C[∞], 238C[∞]; ENGL 103C, 104C[□] (104HC[□]), 106C, <u>201C</u>; PHIL 170C, 172C, 175C	
B. SCIENTIFIC INQUIRY AND QUANTITATIVE REASONING	9 Unit Minimum
<i>Requirement: Must include one course from Physical Science AND one course from Life Science AND one course from Mathematics. One of the Science courses must include a laboratory experience.</i>	
B1/B3. Physical Science w/Lab: ASTR 116C[□]/117C[□] (116HC[□]/117HC[□]); CHEM 100C, 101C, 104C[□], 107C, 111AC, 111BC, <u>200C/200LC</u>; GEOG 102C/102LC; GEOL 100C[□]/101C (100HC[□])/101C, 100C[□]/115C (100HC[□])/115C, <u>102C</u>, 103C, 105 C, 130C/131C; PHSC 104C[□]; PHYS 130C, 201C, 202C, 210C, 211C, 221C, 222C, 223C B2/B3. Life Sciences w/ Lab: ANTH 101C[□] (101HC[□]), 101LC, <u>201C</u>; BIOL 101C[□] (101HC[□]), 111C/112C, 113C/114C, 122C, <u>127C, 128C, 210C, 230C, 231C(begin S06), 240C, 241C(begin S06), 262C</u> B1. Physical Sciences w/o Lab: ASTR 116C[□] (116HC[□]); CHEM 103C[□] (<u>103HC[□]</u>); GEOG 102C; GEOL 100C[□] (100HC[□]), 120C, 125C, 130C, <u>180C[∞], 190C</u> B2. Life Science w/o Lab: ANTH 101C[□] (101HC[□]), <u>201C</u>; BIOL 102C, 103C, 111C, 113C B4. Mathematics and Quantative Reasoning (grade of "C" or better required): CSCI <u>185AC, 185C, 186C, 205C</u>; MATH 100C, 115C, 120C[□] (<u>120HC[□]</u>), 130C, 141C, 142C, 150AC; PSY 161C[□]; SOC 161C[□] 	
C. ARTS AND HUMANITIES	9 Unit Minimum
<i>Requirement: Must include at least one course in the Arts AND one course in the Humanities.</i>	
C1. Arts (Art, Dance, Music and Theater): ART 100C, 110C, 111C, 112C[□] (112HC[□]), 114C, 120C, 150C, 151C, 182C[∞], 189C[∞], <u>212C, 213C, 216C(begin F11)</u>; DANC 101C[∞], 105C[∞](end SU12), 106C[∞](end SU12), 107C[∞](end SU12), 108C[∞](end SU12), 109C[∞](end SU12), 111C[∞](end SU12), 112C[∞](end SU12), 120C; ENGL 125C[□](begin F99); 125HC; INDS 110C[∞]; MUS 101C, 103AC, 113C, <u>115C, 116C, 117C, 118C[∞] (118HC[□]), 119C(begin F01), 120C, 122C^{∞∞∞}, 126C[∞], 127 C, 130C[∞], 135C[∞], 143C[∞], 146C[∞], <u>150C[∞], 282C^{∞∞∞}, 291C[∞]</u>; MMPH 101C[□]; PHOT 101C[□]; THEA 100C, <u>102C[□] (102HC[□]), 104C[∞], 106C[∞], 107C[∞] (107HC[∞]), 120C[∞], 121C[∞], 126C[∞], 129C[∞], 132C[∞], 133C[∞], 145C[∞], 149C[∞]</u> C2. Humanities (Literature, Philosophy, Foreign Languages): CHIN 101C, 102C; COMM 220C[□] (220HC[□]); ENGL 102C[□] (102HC[□]), 110C[□], 111C, 125C[□](F99 - F00 only), 125HC (F99 - F00 only), <u>207C, 208C[∞], 211C, 212C, 221C, 222C, 234C[□] (234HC[□]), 239C[∞], 247C[∞], 255C[∞], 256C[∞]; ETHS 130C[∞](begin F03), 131C[∞], <u>141C[∞], 151C[∞], 152 C, 160C[∞], 171C[∞], <u>176C(begin F03-F04)</u>; FREN 101C, 102C, 200C[∞], 203C, 204C; GERM 101C, 102C; HIST 110AC, <u>110BC, 110C[∞] (110HC[∞]), 111C[∞] (111HC[∞]), 112C[∞] (112HC[∞])(begin F04), 113C[∞] (113HC[∞]), 160C, 161C, <u>160AC[∞], 160BC[∞], 163C[∞], 165C[∞], <u>180C[∞], 275C[∞](begin S05)</u>; INDS 100C[□], 101C[□]; JAPN 101C, 102C, 125C, 200C[∞], 203C, 204C; PHIL 100C[□] (100HC[□]), 101C, 110C, 120C, 135C, 160C, <u>165C, 201C(begin S05), 202C, 240C(begin S06)</u>(formerly 225C), 230C; PORT 101C, 102C(begin S06); SPAN 101C[□] (101HC[□]), 102C[□] (102HC[□]), 200C[∞], 201C, 202C, 203C, 204C </u></u></u></u></u>	

(Continues on next page)

D. SOCIAL SCIENCES	9 Unit Minimum
<i>Requirement: Must take courses in at least two different disciplines</i>	
Note: Students may fulfill Area D by choosing one course from D1-D10, one course from Group A and one course from Group B.	
D1. Anthropology and Archaeology: ANTH 102C [□] (102HC [□]), 104C, 105C, 106 C, 107C, 121C [∞] , 103 C (formerly 203C), 225C	
D2. Economics: ECON 100C, (100HC [□]), 105C [□] (105HC [□]), 110C, 260C [◇] ; GEOG 260 [◇] C [□]	
D3. Ethnic Studies: ETHS 101C ^{◇∞□} (formerly 100 C)(101HC ^{◇∞□})(formerly 100HC), 129C [∞] , 130C ^{◇∞□} , 131C ^{◇∞□} , <u>140C[∞]</u> , <u>141C^{◇∞□}</u> , <u>142C[∞]</u> , 150C [∞] , 151C ^{◇∞□} , 152 C ^{◇∞} , 153 [∞] , 160C ^{◇∞□} , 170C [∞] , 171C ^{◇∞□} , <u>176C</u> ; HS 277C [∞] ; PSY 237C ^{∞□} ; SOC 237C ^{∞□}	
D4. Gender Studies: HIST 270C [◇] ; POSC 101C; SOC 225C [◇]	
D5. Geography: ECON 260C ^{◇□} ; GEOG 100C [□] (100HC ^{∞□}), 130C, 140C, 160C, 260C ^{◇□}	
D6. History: ETHS 101C ^{◇∞□} (formerly 100C)(101HC ^{◇∞□})(formerly 100HC) 130C ^{◇∞□} (begin F03), 131C ^{◇∞□} , <u>141C^{◇∞□}</u> , 151C ^{◇∞} , 152C ^{◇∞} , 160C ^{◇∞□} , 171C ^{◇∞□} , <u>176C</u> ; HIST <u>110AC</u> , <u>110BC</u> , 110C ^{◇□} (110HC ^{◇□}), 111C ^{◇□} (111HC ^{◇□}), 112C ^{◇□} (112HC ^{◇□}), 113C ^{◇□} (113HC ^{◇□}), 135C, 142C, 143C, 151C, 152C, 160C, 161C, <u>160AC[◇]</u> , <u>160BC[◇]</u> , 162AC, 162BC, 163C [◇] , 165C [◇] , 170C [□] (170HC [□]), 171C [□] (171HC [□]), <u>180C[◇]</u> , 270C [◇] (begin F04), 275C ^{◇∞}	
D7. Interdisciplinary, Social or Behavioral Science: COMM <u>118C[□]</u> , 120C [∞] ; ETHS 235C [∞] ; HUSR 200C; JOUR 110C, 118C [□] ; MGT 161C; SOC <u>235C</u>	
D8. Political Science, Government and Legal Institutions: POSC 100C [□] (100HC [□]), 101C, 120C, 130C, 200C, 209C [∞] , 210C, 215C, 216 C, 230C	
D9. Psychology: HUSR 255C ^{◇□} (begin S06); PSY 101C [□] (101HC [□]), 110C, 139C, 145C [◇] (begin S06), 202C (begin F02), 221C (begin F02), 222C, 240C [◇] , 251C, 255C [◇] (begin S06)	
D10. Sociology and Criminology: HUSR 250C ^{◇□} (begin S06), 292C [□] (begin S06); SOC 101C [□] (101HC [□]), 102C (begin F02), 225C [◇] , 250C ^{◇□} (begin S06), <u>271C</u> (begin S06), 275C, 277C, 292C [□] (begin S06)	
CSU Graduation Requirement in U.S History, Constitution, & American Ideals: Note: One course from Group A and one course from Group B may be counted toward the nine-unit minimum in Area D. Group A: POSC 100C [□] (100HC [□]); POSC 101C Group B: ETHS 101C [□] (begin F04)(formerly 100C)(101HC [□])(formerly 100HC), 130C, 131C, 160 C ^{◇∞□} (begin S07); HIST 162AC, 162BC, 170C [□] (170HC [□]), 171C [□] (171HC [□])	
E. LIFELONG UNDERSTANDING AND SELF-DEVELOPMENT	3 Unit Minimum
Integrated Organism: CIS 111C; COMM 105C; COUN 105 C, 141C, 144C, 145C, 146C, 150C, 151C; DANC 100 C, 105 (begin F11), 106C (begin F11), 107C (begin F11), 108 (begin F11), 109C (begin F11), 111C (begin F11), 112C (begin F11), 139C; HRC 100C (begin F04); HUSR 250C ^{◇□} (begin S06), 255C ^{◇□} (begin S06); PE 128C, <u>173C</u> , <u>230C</u> , 231C, 234C, 235C, 237C, 242C [□] , 244C; PSY 120C [□] , 145C [◇] (begin S06), <u>233C</u> , 240C [◇] , 255C ^{◇□} (begin S06); SOC 120C [□] , 250C ^{◇□} (begin S06)	
Activity: ALL PHYSICAL EDUCATION AND DANCE ACTIVITY CLASSES (PE 100C-222C AND DANC 100 C, 105 C - 112 C and 139 C); only one (1) unit of physical activity may count toward fulfillment of this requirement.	
LEGEND	
<ul style="list-style-type: none"> ◦ May be taken (one) 1 time for GE credit ∞ May be taken (two) 2 times for GE credit ∞∞ May be taken three (3) times for GE credit ∞∞∞ Maximum credit four (4) units. ◇ Course may be used to satisfy requirements for one area only. ∞ This class also may be used to satisfy the Cypress College Associate Degree Cultural Diversity requirement. □ Duplicate credit not granted for the same non-honors and honors classes or for the same course listed in two different disciplines. <p>NOTE: Underlining indicates a course is no longer offered at Cypress College. Students may still receive credit, as long as a course was on the official approved list in that category at the time it was taken. The notations reflected after classes represent either the time a class was approved or ended, or that the class is pending approval.</p>	

Please check the **CSU-GE Breadth Certification list** on www.assist.org and confer with a counselor for more information.

INTERSEGMENTAL GENERAL EDUCATION TRANSFER CURRICULUM (IGETC)

The Intersegmental General Education Transfer Curriculum (IGETC) is a general education program which community college transfer students may use to fulfill lower division general education requirements for the California State University (CSU) or University of California (UC) system. Completion of IGETC eliminates the need to take additional lower division general education courses after transfer. Students approaching readiness for transfer who are unable to complete one or two IGETC courses that are not required for admission to the university may request to complete IGETC after transferring. See a counselor for more information.

IGETC is accepted by the University of California, California State University, and by many private institutions. Students wishing to transfer to the University of California or who are undecided about their transfer institution should consult a counselor before choosing this plan.

Students must apply for IGETC certification (full or partial) in the Admissions and Records Office. **Courses will be certified ONLY if they are on the official IGETC list during the catalog year they are taken.**

In addition to the course requirements for each subject area, full certification for the CSU must include completion of the Oral Communications requirement. With the UC, Oral Communications is NOT required, but the certification must include satisfactory completion of the Language Other Than English proficiency requirements. A course or sequence used to satisfy a requirement in one area may not be used to satisfy a requirement in another area. All courses must be completed with a “C” or better. Students must apply for IGETC Certification through the Admissions and Records Office during the semester in which requirements will be completed.

While IGETC is popular with transfer students, it may not be the best choice for you. Depending on your major, it may best to follow the UC campus GE pattern. The UC Transfer Preparation Paths at UCTransfer.org and ASSIST Exploring Majors feature at www.assist.org include information about the specific UC majors that do not recommend IGETC. Students should see a counselor for advice and more complete information on the IGETC program.

****The courses on this list are approved at the time of printing. Check with a counselor or www.assist.org for the most recent list of approved courses.***

INTERSEGMENTAL GENERAL EDUCATION TRANSFER CURRICULUM (IGETC) UNIVERSITY OF CALIFORNIA & CALIFORNIA STATE UNIVERSITY

37 Units Required

Completion of all the requirements in the Intersegmental General Education Transfer Curriculum (IGETC) will permit a student to transfer from Cypress College to a campus in either the California State University or the University of California system without the need, after transfer, to take additional lower division general education courses to satisfy campus general education requirements. However, students approaching readiness for transfer who are unable to complete one or two IGETC courses that are not required for admission to the university may request to complete IGETC after transferring. See a counselor for more information. Transfer students may also fulfill general education requirements that are specific to the school or campus to which they intend to transfer. Completion of **IGETC is NOT an admission requirement to CSU or UC**. It is **NOT** advisable for students who are pursuing majors that require extensive lower division preparation, such as engineering, to follow IGETC. Confer with your counselor regarding these requirements. Students must apply for IGETC certification in Admissions and Records. All courses must be completed with grades of "C" or better. Courses must be at least 3 semester or 4 quarter units in order to meet IGETC requirements. Courses must be on the college's approved IGETC list at the time the course was completed.

AREA 1 – ENGLISH COMMUNICATION REQUIREMENT: CSU: 3 courses required, one from each group below; UC: 2 courses required, one each from Group A and B.
GROUP A: English Composition , 1 course (3 semester units/4-5 quarter units) ENGL 100C [□] (100HC [□])
GROUP B: Critical Thinking / English Composition , 1 course (3 semester/4-5 quarter units) ENGL 103C, 104C [□] (104HC [□]), 106 C (begin F11), 201C; PHIL 172C (Note: Confer with a counselor if ENGL 102, PHIL 170, or SPCH 135 were completed prior to F93).
GROUP C: Oral Communication (CSU requirement only) , 1 course (3 semester/4-5 quarter units) COMM 100C [□] (100HC [□])
AREA 2 – MATHEMATICAL CONCEPTS AND QUANTITATIVE REASONING REQUIREMENT: 1 course (3 semester/4-5 quarter units)
MATH 100C, 115C, 120C [□] (120HC [□]), 130C, 141C, 150AC, 150BC, 250AC, 250BC; PSY 161C [□] ; SOC 161C [□]
AREA 3 – ARTS & HUMANITIES REQUIREMENT: At least 3 courses, with at least one from the Arts and one from the Humanities (9 semester or 12-15 quarter units)
A. ARTS: ART 100C, 110C, 111C, 112C [□] (112HC [□]), 114C, 212C, 213C, 216C; DANC 101C [°] , 120C; ENGL 125C [□] (125HC [□]); INDS 110C; MUS 103AC, 113C [°] , 115C, 116C, 117C, 118C [□] (118HC [□]), 119C(begin F01), 120C; THEA 100C, 102C [□] (102HC [□]), 104C∇, 107C ^{□°} (107HC ^{□°})
B. HUMANITIES: ENGL 102C [□] (102HC [□]), 110C*, 111C*, 207C, 208C [°] , 211C, 212C, 221C, 222C, 234C [□] (234HC [□]), 239C [°] , 247C [°] , 255C [°] , 256C [°] ; ETHS 130C^*(begin F03), 131C^*, 141C ^{°*} , 151C ^{°*} , 152C ^{°*} ; FREN 203C (LOTE), 204C (LOTE); HIST 110AC*, 110BC*, 110C ^{□*} (110HC ^{□*}), 111C ^{□*} (111HC ^{□*}), 112C ^{□*} (112HC ^{□*})(begin S04), 113C* (113HC ^{□*}), 160AC*, 160C*, 160BC*, 161C*, 163C*, 165C*, 180C*, 275C*(begin S05); INDS 100C*, 101C*; JAPN 203C (LOTE), 204C (LOTE); PHIL 100C [□] (100HC [□]), 101C, 110C, 120C, 135C, 160C, 201C(begin S05), 202C, 240C(begin S06)(formerly 225C), 230C; SPAN 202C (LOTE), 203C (LOTE), 204C (LOTE)
AREA 4 - SOCIAL & BEHAVIORAL SCIENCES REQUIREMENT: At least 3 courses from at least two different disciplines or an interdisciplinary sequence (9 semester/12-15 quarter units)
ANTH 102C [□] (102HC [□]), 104C, 105C, 106 C, 107C, 121C [°] , 103C(formerly 203C), 225C; COMM 120C [°] ; ECON 100C [□] (100HC [□]), 105C [□] (105HC [□]), 110C+, 260C [□] ; ETHS 101C ^{□°*} (formerly 100C)(101HC ^{□°*})(formerly 100HC), 129C [°] , 130C^*, 131C^*, 140C [°] , 141C ^{°*} , 142C ^{°*} , 150C [°] , 151C ^{°*} , 152C ^{°*} , 153C [°] , 160C ^{°*} , 170C [°] , 171C ^{°*} , 176C; GEOG 100C [□] (100HC [□]), 130C, 140C, 160C, 260C [□] ; HIST 110AC*, 110BC*, 110C (110HC ^{□*}), 111C ^{□*} (111HC ^{□*}), 112C ^{□*} (112HC ^{□*}), 113C ^{□*} (113HC ^{□*}), 135C(begin S04), 142C(begin S05), 143C, 151C, 152C, 160AC*, 160BC*, 160C, 161C, 162AC^, 162BC^, 163C*, 165C*, 170C ^{□*} (170HC ^{□*}), 171C ^{□*} (171HC ^{□*})(begin F03), 180C*, 270C(begin S04), 275C ^{°*} (begin S05); HUSR 250C [□] (begin S06), 255C [□] (begin S06), 292C [□] (begin S06); POSC 100C ^{□*} (100HC ^{□*}), 101C, 120C, 130C, 200C, 209C [°] , 210C, 215C, 216C, 230C; PSY 101C [□] (101HC [□]), 120C [□] , 139C, 145C(begin S06), 202C, 221C, 222C, 237C ^{°*} , 251C, 255C [□] (begin S06); SOC 101C [□] (101HC [□]), 102C, 120C [□] , 225C, 237C ^{°*} , 250C [□] (begin S06), 275C(begin S05), 277C, 292C [□] (begin S06)

(Continued on next page)

AREA 5 – PHYSICAL AND BIOLOGICAL SCIENCES**REQUIREMENT:** At least 2 courses, one from Group A and one from Group B; at least one course must include a laboratory (7-9 semester/9-12 quarter units)**GROUP A: PHYSICAL SCIENCES****Physical Sciences w/lab:**

ASTR 116C[□]/117C[□] (116HC[□]/117HC[□]); **CHEM** 100C(**begin F02**), 101C(**begin F03**), 107C+, 111AC, 111BC; **GEOG** 102C/102LC;
GEOL 100C[□]/101C+ (100HC[□])/101C+, 100C[□]/115C (100HC[□])/115C, 102C+, 103C, 130C/131C, 220C; **PHYS** 130C+, 201C, 202C,
 210C[□], 211C[□], 221C, 222C, 223C

Sciences w/o lab:

ASTR 116C[□] (116HC[□]); **CHEM** 103C[□] (103HC[□]); **GEOG** 102C; **GEOL** 100C[□] (100HC[□]), 120C, 125 C, 130C, 190C+

GROUP B: BIOLOGICAL SCIENCES**Biological Sciences w/lab:**

ANTH 101C[□] (101HC[□]), 101LC, 201C*; **BIOL** 101C[□]+ (101HC[□]+), 111C/112C+, 113C/114C+, 122C, 127C, 128C+, 210 C(**begin F09**),
230C, 231C(**begin S07**), 240C, 241C(**begin S07**), 262C

Biological Sciences w/o lab:

ANTH 101C[□] (101HC[□]); **BIOL** 102C, 103C, 111C, 113C

GROUP C: PHYSICAL and BIOLOGICAL SCIENCE LABORATORIES**(ALL SCIENCE LABS THAT COMBINE LECTURE AND LAB OR LAB ONLY COURSES):**

ANTH 101LC, 201C*; **ASTR** 117C[□] (117HC[□]), **BIOL** 101C[□]+ (101HC[□]+), 112C+, 114C+, 122C, 127C, 128C+, 210C(**begin F09**),
230C, 231C(**begin S07**), 240C, 241C(**begin S07**), 262C, **CHEM** 100 C (**begin F02**), 101 C (**begin F03**), 107C+, 111AC, 111BC, **GEOG** 102LC,
GEOL 101 C, 103 C, 115 C, 131C, **PHSC** 130 C+, 201 C, 202 C, 210 C[□], 211C[□], 221C, 222C, 223

AREA 6A – LANGUAGE OTHER THAN ENGLISH: (UC requirement only)**REQUIREMENT:** Complete one of the following:

1. Complete 2 years of high school foreign language in the same language with a grade of "C" or better.
2. Earn a score of 3 or higher on the Foreign Language Advanced Placement test.
3. Earn a minimum score of 550 on the SAT II Subject Test in languages other than English.
4. Complete course 102C[□] (102HC[□]) or higher level in a foreign language at Cypress College or equivalent courses at another college or university.
5. Completion with "C" grade or better of 2 years of formal schooling at the 6th grade level or higher at an institution where the language of instruction is not English.
6. Earn a score of 5 or higher on the International Baccalaureate Higher Level Exam in a language other than English.
7. Earn an A, B, or C on LOTE "O" level exam.
8. Earn a score of 5, 6, or 7 on LOTE International "A" Level Exam.

Cypress College courses that meet the proficiency level: **CHIN** 102C; **FREN** 102C; **GERM** 102C; **JAPN** 102C; **PORT** 102C(**begin S06**);
SPAN 102C[□] (102HC[□]), 201C

Note: A higher-level language course can be used to meet language proficiency. Students completing such courses will satisfy both the 3B Area and validate the proficiency level requirement. *These courses are identified in the 3B area as (LOTE).*

CSU GRADUATION REQUIREMENT IN U.S. HISTORY, CONSTITUTION, AND AMERICAN IDEALS**(Not part of IGETC, may be completed prior to transfer.)** (6 semester units, one course from Group A and one course from Group B)**Group A:** **POSC** 100C[□] (100HC[□]), 101C**Group B:** **ETHS** 101 C[□](**begin F04**)(formerly 100C) (101HC[□])(formerly 100HC), 130C, 131C, 160C; **HIST** 162AC, 162BC, 170C[□] (170HC[□]), 171C[□] (171HC[□])

Note: The CSU US History, Constitution, and American Ideals (AI) graduation requirement is not part of IGETC. CSU campuses have the discretion whether to allow courses used to satisfy this AI graduation requirement for CSU to double-count in Area 3B or 4F. See a counselor for more information. These courses may also be used to satisfy the UC American History & Institution requirement if not completed in high school. Since requirements vary, it is advisable to check the catalog of the UC campus to which the student intends to transfer.

Legend

+ Check with counselor for credit limitations for applicable courses in these departments: **BIOLOGY, CHEMISTRY, DANCE, ECONOMICS, GEOLOGY, MATH, PHOTOGRAPHY, PHYSICS, PSYCHOLOGY, SOCIOLOGY and THEATER**. Specific credit limitation information is available at www.assist.org

* Course may be used to satisfy requirements for only one area (exception for LOTE courses, 3B & 6A)

□ Duplicate credit not granted for the same non-honors and honors classes or for the same course listed in two different disciplines.

∇ May be taken only one time for GE credit.

^ See CSU graduation requirement in U.S. History, Constitution, and American Ideals.

* The class also may be used to satisfy the Cypress College Associate Degree Cultural Diversity requirement.

NOTE: Underlining indicates a course is no longer offered at Cypress College. Students may still receive credit, as long as a course was on the official approved list in that category at the time it was taken. The notations reflected after classes represent either the time a class was approved or ended, or that the class is pending approval.

Please check the IGETC Certification list on www.assist.org and with a counselor for more information.

GENERAL EDUCATION CERTIFICATION (GE) and PASS ALONG

Students planning to graduate from the California State University or University of California systems must complete a minimum number of general education breadth courses. Cypress College is permitted to certify completion of the lower division general education requirement. Certification is not automatic. To meet general education requirements and obtain certification, students must:

- Complete the pattern of general education courses approved for Cypress College.
- Apply for GE certification through the Admissions and Records Office or online at www.CypressCollege.edu during the semester in which requirements will be completed or thereafter.

Students with transcripts from other educational institutions should see a counselor to obtain a supplemental “pass along” form which must be attached to the certification application. Courses completed at educational institutions outside the United States cannot be used for “pass along” and these courses must be evaluated by the university during the application process. Students do not have to be currently enrolled in Cypress College to apply for GE certification.

Description of Courses

The following section includes a description of every course which may be studied at Cypress College. The prerequisite(s) for the class is stated, if applicable. The program of instruction related to the numbering of courses is divided into major categories:

- College and university parallel courses (transfer courses) have title numbers ranging from 100 through 299. If appropriate to the student’s major, they usually will be accepted as transfer units to institutions of higher education for their full credit value.
- Several general education courses, in addition to occupational, vocational and technical courses will bear the title numbers ranging from 001 through 099 and generally are not transferable to institutions of higher education except as they apply to major programs in the California State Universities. Students are advised to confer with their counselors regarding the transferability of these courses to particular colleges or universities. Students entering Cypress College should consult with college counselors in planning their programs of study. The faculty and counseling staff of Cypress College will assist students in every way possible to make wise vocational and educational plans. Students, however, must assume the responsibility for their own choices and plans.

NON-DEGREE CREDIT courses indicated as NON-DEGREE CREDIT do earn credit, but the credit is not counted toward the Associate Degree. These classes are intended to help students gain the skills they need to perform in college level degree applicable courses. NON-DEGREE CREDIT classes count toward the following categories: Athletic Eligibility, Social Security Benefits, Work Study and Financial Aid, Veterans’ Benefits, Associated Student Body Office and Full-Time Status. All other Cypress College courses are degree applicable.

UC/CSU designated courses are transferable to the campuses of the University of California and the California State University system. Those courses that are not marked **UC** are not transferable to the University of California campuses. Confer with a counselor for information regarding transferability of courses marked **UC Limitation**. Students can view a complete list of Cypress College courses that are transferable to the UC at www.assist.org.

CSU GE — These courses satisfy general education breadth requirements for California State Universities (CSU campuses).

AA GE — Courses which satisfy general education requirements for the Associate Degree.

IGETC — Intersegmental General Education Transfer Curriculum is a series of courses that Cypress College students may use to satisfy lower division general education requirements at any CSU or UC campus.

CUL DIV — Courses with the **Cultural Diversity** designation are ones which meet the Cypress College Cultural Diversity graduation requirement.

RDG — Courses with the Reading Proficiency designation are ones which meet the Cypress College reading proficiency graduation requirement.

TRANSFER CREDIT — BACCALAUREATE DEGREES

Cypress College certifies that the following classes listed (by instructional divisions) are baccalaureate-level classes and are transferable to any campus of the California State University system for credit toward its baccalaureate degrees:

Business and Computer Information Systems — All classes numbered 100 C through 299 C.

Counseling and Guidance — All classes numbered 100 C through 299 C.

Fine Arts — All classes numbered 100 C through 299 C.

Health Science — All classes numbered 100 C through 299 C.

Language Arts — All classes numbered 100 C through 299 C.

Physical Education — All classes numbered 100 C through 299 C.

Science/Engineering/Mathematics — All classes numbered 100 C through 299 C; Basic Electricity 051 C is transferable only for Industrial Arts Majors.

Social Science — All classes numbered 100 C through 299 C.

Vocational Technical Education — All classes numbered 100 C through 299 C; Aviation 050 C and Photography 050 C.

Note: All Honors classes offered at Cypress College are transferable to any campus of the California State University system.

GENERAL EDUCATION AND BASIC SKILLS PROGRAM LEARNING OUTCOMES

The General Education and Basic Skills Program is considered as one complete program. The General Education and Basic Skills Student Learning Outcomes are broad categories that include courses approved for the Cypress College AA/AS Degree General Education, the California State University General Education, and the Intersegmental General Education Transfer Curriculum (IGETC) pathways, and the prerequisite basic skills courses. The Cypress College Institutional Learning Outcomes adopted in Spring 2004 were reviewed and written as statements rather than topics in four major areas or competencies. Portions of Cabrillo College's General Education and Basic Skills SLOs were used with permission.

I. Breadth of Knowledge and Experiences

Students will possess a breadth of knowledge and experiences from the following areas:

- A. Humanities and the Arts
 1. Aesthetic Awareness: Examine the visual arts, dance, music, and/or literature of diverse cultures.
 2. Critical Analysis: Assess the methods used to create art and interpret its literal and/or symbolic meaning.
 3. Creativity: Engage in artistic creative endeavors.
- B. Natural Sciences and Mathematics
 1. Scientific Principles: Demonstrate an understanding of scientific principles that govern the natural and mathematical universe.
 2. The Scientific Method: Apply scientific processes to solve problems and measure and observe natural phenomena, including the design, performance, and analysis of experiments.
 3. Mathematical Systems: Demonstrate an understanding of mathematics as a symbolic, universal language.
- C. Social Sciences
 1. Cultural Competence: Demonstrate knowledge and understanding of the feelings, opinions, and/or values of other people and cultures
 2. Global Perspective: Recognize important economic, political, social, and historical issues and values in one's own community, state, country, and/or the world.
 3. Human Experience: Use qualitative and/or quantitative methods to study the human aspects of the world.
- D. Physical Education
 1. Fitness: Understand the development, care, and exercise of the human body through movement.
 2. Health and Nutrition: Understand and apply the principles of nutrition, hygiene, and safety to develop mental and physical well-being.
 3. Movement Competence: Perform learned skills competently.

II. Communication

Students will communicate effectively, which means the ability to

- A. Read:
 1. Comprehend, interpret, and/or evaluate various written information.

- B. Write:
 1. Communicate thoughts, ideas, information, and messages in writing.
 2. Compose and create documents with correct grammar, spelling, punctuation, and appropriate language, style, and format.
 3. Check, edit, and revise written work for correct information, appropriate emphasis, form, style, and grammar.
- C. Listen:
 1. Sense and appropriately perceive and respond to verbal and/or nonverbal messages.
- D. Communicate:
 1. Organize ideas and communicate verbal and/or non-verbal messages appropriate to the audience and the situation.
 2. Communicate clearly and ask relevant questions in conversations, discussions, group activities, and/or public speaking.

III. Critical Thinking and Information Competency

Students will think critically, which is characterized by the ability to

- A. Analyze:
 1. Recognize and apply rules and principles to new situations.
 2. Use logic (induction and deduction) to draw conclusions from information given.
 3. Differentiate between facts, inferences, assumptions, and/or conclusions.
- B. Compute:
 1. Use basic numerical concepts, such as whole numbers, percentages, and estimates of math without a calculator.
 2. Use tables, graphs, charts, and diagrams to explain concepts or ideas.
 3. Use basic geometrical shapes, such as lines, angles, shapes, and space.
- C. Research:
 1. Effectively and ethically acquire, organize, analyze, synthesize, evaluate and communicate information.
 2. Determine which technology resources will produce the desired results
- D. Solve Problems:
 1. Define a problem and identify its components.
 2. Create a plan of action to resolve the issue.
 3. Execute and evaluate the effectiveness of the plan.

IV. Self Development

Students will develop self-awareness and responsibility by means of the following:

- A. Self Integration
 1. Understand the person as an integrated physiological, social, and psychological being.
- B. Personal Responsibility
 1. Develop skills and identify values for personal growth and life-long learning.
- C. Global Citizenship
 1. Understand the interconnection between current events, ethics, and personal and societal choices within our world.



Programs

Course Descriptions

Course Prefixes

ACCT	Accounting	HS	Health Science
AC/R	Air Conditioning/Refrigeration	HSCE	Health Science — Continuing Education
ACR	Automotive Collision Repair	HUSR	Human Services
AJ	Administration of Justice	INDS	Interdisciplinary Studies
ANTH	Anthropology	JAPN	Japanese
ART	Art	JOUR	Communications/Journalism
ASTR	Astronomy	LAR	Learning and Academic Resources
AT	Automotive Technology	LIB	Library
ATC	Airline and Travel Careers	MAD	Media Arts Design
AVIA	Aviation	MATH	Mathematics
BIOL	Biology	MGT	Management
CHEM	Chemistry	MKT	Marketing
CHIN	Chinese	MORT	Mortuary Science
CIS	Computer Information Systems (Business)	MRN	Marine Service Technician
COMM	Communication Studies	MM	Multimedia
COUN	Counseling and Student Development	MT	Motorcycle Technology
CSCI	Computer Science (Mathematics)	MUS	Music
CTRP	Court Reporting	NURS	Nursing
DA	Dental Assistant	PE	Physical Education
DANC	Dance	PHIL	Philosophy and Religious Studies
DH	Dental Hygiene	PHOT	Photography
DMS	Diagnostic Medical Sonography	PHSC	Physical Science
ECON	Economics	PHYS	Physics
EDU	Education	PORT	Portuguese
ELEC	Electricity	POSC	Political Science
ENGL	English	PSY	Psychology
ENGR	Engineering	PT	Psychiatric Technology
ENGT	Engineering Technology	RADT	Radiologic Technology
ESL	English as a Second Language	RE	Real Estate/Escrow
ETHS	Ethnic Studies	REC	Recreation
FREN	French	SOC	Sociology
GEOG	Geography	SOSC	Social Science
GEOL	Geology	SPAN	Spanish
HI	Health Information Technology	THEA	Theater Arts
HIST	History	WELD	Welding
HRC	Hotel, Restaurant, Culinary Arts	WKEX	Work Experience

Standard Definitions

Definition of *Advisory*

When a course has an *advisory*, it means that a student is recommended to have certain preparation before entering the course. The preparation is considered advantageous to a student's success in the course. Since the preparation is recommended, the student is advised, but not required, to meet the condition before or in conjunction with enrollment in the course or educational program (eligibility for ENGL 100 C is recommended for POSC 100 C).

Definition of *Articulation*

Articulation agreements define how courses will transfer from one institution to another. Cypress College maintains major and/or course-to-course articulation agreements with most public universities and many independent colleges and universities in the state of California. The agreements with the public institutions are listed on www.assist.org which is the official repository for articulation in the state. Many independent institutions have articulation information available on their websites. In addition, agreements with public and independent institutions are located in the Transfer Center and Counseling Center.

Definition of *Associate Degrees for Transfer*

California Community Colleges are now offering associate degrees for transfer (AD-T) to the CSU. These may include Associate in Arts or Associate in Science degrees. These degrees are designed to provide a clear pathway to a CSU major and baccalaureate degree. California Community College students who are awarded an AD-T degree are guaranteed admission with junior standing somewhere in the CSU system and given priority admission consideration to their local CSU campus or to a program that is deemed similar to their community college major. This priority does not guarantee admission to specific majors or campuses.

The AD-T degree is intended for students who plan to complete a bachelor's degree in a similar major at a CSU campus. Students who have been awarded an AD-T are able to complete their remaining requirements for the 120-unit baccalaureate degree within 60 semester or 90 quarter units. To view the most current list of Cypress College Associate Degrees for Transfer and to find out which CSU campuses accept each degree, please go to www.CypressCollege.edu/services/transfer

Current and prospective community college students are encouraged to meet with a counselor to review their options and learn how to develop an educational plan that best meets their goals and needs as it relates to university admission and transfer requirements.

Definition of *ASSIST*

ASSIST is a computerized student-transfer information system that can be accessed over the World Wide Web. It displays reports of how course credits earned at one California college or university can be applied when transferred to another. ASSIST is the official repository of articulation for California's colleges and universities and therefore provides the most accurate and up-to-date information available about student transfer in California. ASSIST is available at: www.assist.org.

Students should consult the ASSIST database for specific information on course agreements. The counselors and Transfer Center staff can help students interpret this information.

Definition of *Corequisite*

When a course has a *corequisite*, it means that a student is required to take another course concurrent with or prior to enrollment in the course. Knowing the information presented in the corequisite course is considered necessary in order for a student to be successful in the course (completion of, or concurrent enrollment in, ASTR 116 C is required for ASTR 117 C).

It is the student's obligation to know and meet course corequisites. These are stated in the course description section of the *Class Schedule* and the current *College Catalog*. The student may be required to file proof of meeting corequisites on the first day of class.

Definition of *Course Identification Numbering System (C-ID)*

The Course Identification Numbering System (C-ID) is a statewide numbering system independent from the course numbers assigned by local California community colleges. A C-ID number next to a course signals that participating California colleges and universities have determined that courses offered by other California community colleges are comparable in content and scope to courses offered on their own campuses, regardless of their unique titles or local course number. Thus, if a schedule of classes or catalog lists a course bearing a C-ID number, for example COMM 110, students at that college can be assured that it will be accepted in lieu of a course bearing the C-ID COMM 110 designation at another community college. In other words, the C-ID designation can be used to identify comparable courses at different community colleges. However, students should always go to www.assist.org to confirm how each college's course will be accepted at a particular four-year college or university for transfer credit.

The C-ID numbering system is useful for students attending more than one community college and is applied to many of the transferable courses students need as preparation for transfer. Because these course requirements may change and because courses may be modified and qualified for or deleted from the C-ID database, students should always check with a counselor to determine how C-ID designated courses fit into their educational plans for transfer.

Students may consult the ASSIST database at www.assist.org for specific information on C-ID course designations. Counselors can always help students interpret or explain this information.

Definition of Electives

An *elective* is a course not required for graduation or for the fulfillment of requirements for a program. For example, a science student might take electives from non-science areas, which might include history, art, English, music, or political science. A history student might take electives from biology, chemistry, art, music or English literature. To assist in choosing electives, a student should consult a counselor and the catalog of the college to which he/she expects to transfer.

Definition of Prerequisite

When a course has a *prerequisite*, it means that a student must have certain knowledge to be successful in the course. The prior knowledge may be a skill, an ability (speaks and writes Spanish fluently), a test score, or a successful completion of a prior course (must have completed ENGL 060 C with a grade of “C” or better). Completion of the prerequisite is required prior to enrolling in the course. Successful completion of a prerequisite course means that a grade of *Pass*, or *C*, or better was earned; *D*, *F*, or *No Pass* grades are not acceptable.

Prerequisites for all courses are explained in the *Class Schedule* and the current *College Catalog* under the listing for the class. It is the student’s obligation to know and meet course prerequisites. The student may be required to file proof of meeting prerequisites on the first day of class.

Definition of Unit

Course work at Cypress College is measured in terms of semester units. In general, a unit equals eighteen hours of lecture or fifty-four hours of laboratory work per semester. Some courses combine different types of approaches and the units are adjusted accordingly. Hours per week for short-term courses are prorated based on the semester course hours.

Description of Courses

The following section includes a description of every course which may be studied at Cypress College. The prerequisite(s) for the class is stated, if applicable.

The program of instruction related to the numbering of courses is divided into major categories:

- College and university parallel courses (transfer courses,) have title numbers ranging from 100 through 299. If appropriate to the student’s major, they usually will be accepted as transfer units to institutions of higher education for their full credit value.
- Several general education courses, in addition to occupational, vocational and technical courses will bear the title numbers ranging from 001 through 099 and generally are not transferable to institutions of higher education except as they apply to major programs in the California State Universities. Students are advised to confer with their counselors regarding the transferability of these courses to particular colleges or universities.

Students entering Cypress College should consult with college counselors in planning their programs of study. The faculty and counseling staff of Cypress College will assist students in every way possible to make wise vocational and educational plans. Students, however, must assume the responsibility for their own choices and plans.

NON-DEGREE CREDIT courses indicated as NON-DEGREE CREDIT do earn credit, but the credit is not counted toward the Associate Degree. These classes are intended to help students gain the skills they need to perform in college level degree applicable courses. NON-DEGREE CREDIT classes count toward the following categories: Athletic Eligibility, Social Security Benefits, Work Study and Financial Aid, Veterans’ Benefits, Associated Student Body Office and Full-Time Status. All other Cypress College courses are degree applicable.

UC/CSU — designated courses are transferable to the campuses of the University of California and the California State University system. Those courses that are not marked **UC** are not transferable to the University of California campuses. Confer with a counselor for information regarding transferability of courses marked **UC Limitation**. Students can view a complete list of Cypress College courses that are transferable to the UC at www.assist.org.

CSU GE — These courses satisfy general education breadth requirements for California State Universities (CSU campuses).

AA GE — Courses which satisfy general education requirements for the Associate Degree.

IGETC — Intersegmental **General Education Transfer Curriculum** is a series of courses that Cypress College students may use to satisfy lower division general education requirements at any CSU or UC campus.

CUL DIV — Courses with the **Cultural Diversity** designation are ones which meet the Cypress College Cultural Diversity graduation requirement.

RDG — Courses with the Reading Proficiency designation are ones which meet the Cypress College reading proficiency graduation requirement.

Transfer Credit Baccalaureate Degrees

Cypress College certifies that the following classes listed (by instructional divisions) are baccalaureate-level classes and are transferable to any campus of the California State University system for credit toward its baccalaureate degrees:

Business and Computer Information Systems — All classes numbered 100 C through 299 C.

Career Technical Education — All classes numbered 100 C through 299 C; Aviation 050 C and Photography 050 C.

Counseling and Guidance — All classes numbered 100 C through 299 C.

Fine Arts — All classes numbered 100 C through 299 C.

Health Science — All classes numbered 100 C through 299 C.

Language Arts — All classes numbered 100 C through 299 C.

Physical Education — All classes numbered 100 C through 299 C.

Science/Engineering/Mathematics — All classes numbered 100 C through 299 C; Basic Electricity 051 C is transferable only for Industrial Arts Majors.

Social Sciences — All classes numbered 100 C through 299 C.

Note: All Honors classes offered at Cypress College are transferable to any campus of the California State University system.

Accounting

Division of Business and Computer Information Systems

Division Dean — Dave Wassenaar

Faculty
Jeanne Miller

Counselor
Robert Grantham

PROGRAM LEARNING OUTCOMES (PLOs)

Accounting

A student who completes the Accounting field of study will be able to:

- Acquire problem analysis skills including analyzing transactions, performing break even analysis, and utilizing accounting software to design suitable solutions
- Enhance his/her employment opportunity in the specific area of accounting

ASSOCIATE IN SCIENCE DEGREE

ACCOUNTING Program Code: 1S03761

This curriculum is designed to prepare the student for employment in the field of general bookkeeping and accounting. A graduate from this program should be equipped to meet the demands of any organization requiring skills in general accounting, cost accounting and analysis of financial information.

To earn an Associate Degree students must complete: (1) all major course requirements with a minimum grade of "C"; (2) 25 units of General Education Graduation Requirements; (3) the cultural diversity and reading requirements; (4) any elective courses to complete a minimum of 60 units; and, (5) have a minimum GPA of 2.0. At least 50% of all major course work must be completed at Cypress College.

Courses that fulfill major requirements for an Associate Degree at Cypress College might not be the same as those required for completing the major at a transfer institution offering a Baccalaureate Degree. For information on specific university requirements, please consult with your counselor, or visit the Transfer Center.

Required courses are listed in suggested sequence:

Course #	Title	Units
ACCT 101 C	Financial Accounting	4
CIS 111 C	Computer Information Systems	3
MGT 151 C	Business Mathematics	3
ACCT 102 C	Managerial Accounting	4
ACCT 190 C	Accounting Sys. Design and Appl.	3
MGT 111 C	Business Communications	3
	or	
MGT 211 C	Writing for Business	(3)
*ECON 105 C	Principles of Economics — Micro	3
	or	
*ECON 105HC	Honors Principles of Economics	(3)
	or	
ECON 110 C	Survey of Economics	(3)
ACCT 201 C	Intermediate Accounting	3
ACCT 011 C	Payroll Accounting	2
ACCT 202 C	Cost Accounting	3
ACCT 204 C	Acct-Govt and Nonprofit Entities	3
Total Units Required		34

*A score of 3 or higher on the Advanced Placement (AP) Economics (micro) exam meets this requirement upon petition through Admissions and Records. See a counselor for more information.

ACCOUNTING CERTIFICATE Program Code: 1C21094

The primary emphasis of this program is to prepare the student for occupational competency.

To earn a certificate, students must complete the required courses as listed with a minimum grade of "C." At least 50% of all course work must be completed at Cypress College.

Required courses are listed in suggested sequence:

Course #	Title	Units
ACCT 101 C	Financial Accounting	4
CIS 111 C	Computer Information Systems	3
MGT 151 C	Business Mathematics	3
ACCT 102 C	Managerial Accounting	4
ACCT 190 C	Accounting Sys. Design and Appl.	3
MGT 111 C	Business Communications	3
	or	
MGT 211 C	Writing for Business	(3)
ACCT 201 C	Intermediate Accounting	3
ACCT 011 C	Payroll Accounting	2
ACCT 202 C	Cost Accounting	3
ACCT 204 C	Acct-Govt and Nonprofit Entities	3
Total Units Required		31

ASSOCIATE IN ARTS DEGREE

BUSINESS Program Code: 1A16599

This curriculum is designed to provide an opportunity for the business major to achieve an Associate in Arts Degree Business Administration while completing the first and second year requirements for transfer to a four-year institution. While a baccalaureate degree is recommended preparation for those considering professional careers in business administration, completion of this curriculum will demonstrate commitment to the field and provide comprehensive preparation for upper-division work.

Students should consult a counselor and the catalog of the individual college or university to plan a program of study. The Internet site www.assist.org will also provide information for California public universities. Courses selected to fulfill the requirements of the associate degree should reflect requirements of the college to which the student plans to transfer.

To earn an Associate Degree students must complete: (1) all major course requirements with a minimum grade of "C"; (2) California State University General Education Breadth requirements (CSU GE Breadth) or IGETC General Education Plan; (3) any elective courses to complete a minimum of 60 units; (4) complete all graduation requirements; and, (5) have an overall GPA of 2.0. At least 50% of all major course work must be completed at Cypress College. **Students pursuing more than one specified departmental major may double count a maximum of 7 units to fulfill major requirements.**

Courses that fulfill major requirements for an Associate Degree at Cypress College might not be the same as those required for completing the major at a transfer institution offering a Baccalaureate Degree. For information on specific university requirements, please consult with your counselor, or visit the Transfer Center.

Required courses are listed in suggested sequence:

Course #	Title	Units
MGT 161 C	Introduction to Business	3
CIS 111 C	Computer Information Systems	3
*ECON 100 C	Principles of Economics — Macro or	3
*ECON 100HC	Honors Principles of Economics	(3)
**ECON 105 C	Principles of Economics — Micro or	3
**ECON 105HC	Honors Principles of Economics	(3)
MGT 240 C	Legal Environment of Business or	3
MGT 241 C	Legal Aspects — Business Transactions	(3)
ACCT 101 C	Financial Accounting	4
ACCT 102 C	Managerial Accounting	4
MATH 130 C	Survey of Calculus	4
MKT 222 C	Principles of Marketing	3
Total Units Required		30

Electives

MGT 211 C	Writing for Business	3
-----------	----------------------	---

*A score of 3 or higher on the Advanced Placement (AP) Economics (macro) exam meets this requirement upon petition through Admissions and Records. See a counselor for more information.

**A score of 3 or higher on the Advanced Placement (AP) Economics (micro) exam meets this requirement upon petition through Admissions and Records. See a counselor for more information.

ACCOUNTING TRANSFER PROGRAM

Students should consult a counselor or www.assist.org for lower division major requirements for most California public universities. (See the Standard Definitions section of the catalog for a description of ASSIST.) Students transferring to an independent college/university should consult the catalog of the individual school and a counselor for lower division major requirements.

Accounting (ACCT)

ACCT 011 C Payroll Accounting 2 Units

Prerequisite: ACCT 101 C.

Term hours: 32–36 lecture and 16–18 TBA laboratory. This course is a thorough study of payroll computation techniques and payroll taxes. The course is of a non-technical nature and is intended to give students a practical working knowledge of current payroll tax laws. Pass/No Pass/Letter Grade Option. \$3.00 Material Fee — Payable at Registration.

ACCT 099 C Bookkeeping Principles and Practices 3 Units

Term hours: 48–54 lecture and 16–18 TBA laboratory. This is a basic course in financial record keeping using the double-entry system for recording transactions in service and merchandising businesses. A systematic approach to journals, ledgers, and financial statements as utilized in sole proprietorships will be studied. \$3.00 Material Fee — Payable at Registration.

ACCT 101 C Financial Accounting 4 Units

Term hours: 80–90 lecture. A course in beginning accounting meets transfer requirements to four-year colleges and universities and provides a foundation for vocational accounting or other areas of business administration. This course describes and illustrates financial accounting theory and principles, including classification of accounts, recording of financial transactions, presentation and analysis of financial statements, and fundamentals of the accounting cycle as applied to service and merchandising enterprises. Credit by Examination. (UC/CSU)

ACCT 102 C Managerial Accounting 4 Units

Prerequisite: ACCT 101 C with a grade of "C" or better.

Advisory: Knowledge of spreadsheet software recommended.

Term hours: 80–90 hours lecture and 16–18 laboratory TBA. This course provides a foundation for advanced courses in managerial accounting. Instructional topics include the application of managerial accounting to a manufacturing environment, job and process cost accounting systems, cost allocation, cost-volume-profit analysis, absorption and variable costing, differential analysis for decision making, capital investment analysis, budgeting, financial statement analysis, standard costing, and responsibility accounting in a decentralized operation. Computer applications that require knowledge of spreadsheet software are integrated into the homework. This course is required of all accounting and business administration majors. \$3.00 Material Fee — Payable at Registration. (UC/CSU)

ACCT 103 C Computerized Accounting 1 Unit

Prerequisite: ACCT 099 C or ACCT 101 C.

Term hours: 16–18 lecture and 16–18 TBA laboratory. This course introduces students to starting and using a small business computerized accounting system. Students will utilize computerized accounting software to create a chart of accounts, record journal entries, prepare financial statements, and create supporting reports useful in making business decisions. \$3.00 Material Fee — Payable at Registration. (CSU)

ACCT 112 C Income Tax Procedures 3 Units

Prerequisite: ACCT 101 C.

Term hours: 48–54 lecture. This course is an introduction to Federal Income Tax as applied to individuals, partnerships, and corporations. The application of laws and regulations to the preparation of income tax returns is involved. (CSU)

ACCT 190 C Accounting Systems Design and Applications 3 Units

Prerequisite: ACCT 101 C.

Advisory: Knowledge of spreadsheet software recommended.

Term hours: 48–54 lecture and 16–18 TBA laboratory. The course offers the student a hands-on approach to computerized accounting. Students will explore different manual and computerized accounting systems such as General Ledger, Accounts Receivable, Accounts Payable, Payroll and Inventory. \$3.00 Material Fee — Payable at Registration. (CSU)

ACCT 201 C Intermediate Accounting**3 Units***Prerequisite: ACCT 101 C.*

Term hours: 48–54 lecture. This course covers intermediate accounting theory and practice. The subject areas include: preparation and theory of principle accounting statements; recording, valuation, and presentation of cash; temporary investments; receivables, inventories, plant and equipment, intangible assets and liabilities; stockholders equity, retained earnings and paid-in-capital, statements and financial statement analysis. (CSU)

ACCT 202 C Cost Accounting**3 Units***Prerequisite: ACCT 102 C with a grade of "C" or better.*

Term hours: 48–54 lecture. This course covers the nature, objectives, and procedures of cost accounting and managerial control of operations. It includes job, process, and standard costing; accounting for manufacturing overhead, direct materials and direct labor; budgeting; and cost records and reports. (CSU)

ACCT 204 C Acct — Government and Nonprofit Entities**3 Units***Prerequisite: ACCT 101 C.*

Term hours: 48–54 lecture. This course introduces financial accounting concepts as they apply to governmental and not-for-profit entities, such as federal, state and local governments, school districts, universities, hospitals, religious and social service organizations. The focus is on the principles and procedures of accounting, financial reporting, budgeting and auditing requirements. (CSU)

ACCT 295 C Accounting Internship**1 to 4 Units**

Term hours: 16–18 hours lecture and 53–60 hours laboratory. This course is designed to give the student credit for work experience at a related occupational worksite, while being concurrently enrolled in a vocational major. For each unit of credit, a minimum of 75 paid or 60 unpaid worksite internship hours is required. The internship allows students to apply knowledge gained in college courses to an actual work setting, sample career choices and improve job-readiness skills. Supplemental reading and course assignments required. May be taken for credit 4 times. Open Entry/Open Exit. Pass/No Pass/Letter Grade Option. (CSU)

Administration of Justice

Division of Career Technical Education*Division Dean — Steve Donley**Counselor*

Jane Jepson

Administration of Justice (AJ)

AJ 100 C Introduction to Law Enforcement**3 Units**

Term hours 48–54 lecture. This is a course to acquaint the student with the historical development of the criminal justice system, criminal behavior, the purpose of criminal law, and the advancement of the ethics and professionalization of the justice system. It provides an overview of the organization of local, state and federal law enforcement agencies and an analysis of professional career opportunities. (CSU)

AJ 110AC Criminal Law**3 Units***Prerequisite: AJ 100 C.*

Term hours 48–54 lecture. This course is a study of the elements of crimes against persons, property and the State as they are recognized in the Penal Code and General Laws of California. Parties in crime, culpability and incomplete offenses are presented from the point of view of the Peace Officer and the Courts. (CSU)

Administrative Support — See Computer Information Systems (CIS)

Aeronautics — See Aviation (AVIA)

Air Conditioning and Refrigeration

Division of Career Technical Education*Division Dean — Steve Donley**Faculty*Richard Hock
Douglas Sallade
Carlos Urquidi*Counselor*

Jane Jepson

PROGRAM LEARNING OUTCOMES (PLOs)

A student that completes the Air Conditioning and Refrigeration program will have acquired a specific skill set and will have achieved the necessary competencies for HVAC/R industry employment.

ASSOCIATE IN SCIENCE DEGREE AIR CONDITIONING AND REFRIGERATION

Program Code: 1S03774

This program is designed as the bridge between Engineering and Service Technology. It will provide students with technical skills to support engineering applications. Graduates of the program will be at the leading edge of the application of new engineering solutions to production in industry. To earn an Associate Degree students must complete: (1) all 39.5–40 units of Air Conditioning and Refrigeration course requirements for the Certificate in Air Conditioning and Refrigeration with a minimum grade of “C”; (2) 25 units of General Education Graduation Requirements, including the cultural diversity and reading requirements and any elective courses to complete a minimum of 60 units; and, (3) have a minimum GPA of 2.0. At least 50% of all major course work must be completed at Cypress College. Courses that fulfill requirements for an Associate Degree at Cypress College might not be the same as those required for completing the major at a transfer institution offering a Baccalaureate Degree. For information on specific university requirements, please consult with your counselor, or visit the Transfer Center.

Required courses are listed in suggested sequence:		Units
AC/R 100 C	Prin. of Thermodynamics and Heat Transfer	3
AC/R 110 C	Air Conditioning I	3
AC/R 120 C	Piping Practice, Tools and Safety	2
AC/R 036 C	Refrigerants, Charging and Recovery	1
AC/R 037 C	Blueprints and Dimension Analysis	2
AC/R 105 C	Electricity for A/C and Refrig I	3
AC/R 115 C	Gas Heating and Carbon Monoxide	3
AC/R 145 C	Load Calcs for Heat and Cool	2
AC/R 106 C	Electricity for A/C and Refrig II	3
AC/R 210 C	Commercial Refrigeration	3
AC/R 220 C	A/C Controls and Energy Mgt.	2
AC/R 230 C	Heat Pumps	2
AC/R 205 C	Commercial Air Conditioning	3
AC/R 215 C	Codes and Estimating for HVACR	3
AC/R 035 C	Building Commissioning	2
AC/R 055 C	Technician Customer Relations	2
AC/R 050 C	HVAC/R Special Projects	.5–1
Total Units		39.5–40

AIR CONDITIONING AND REFRIGERATION CERTIFICATE

Program Code: 1C31173

Primary emphasis of this program is to prepare the student with job entry-level skills. Although further training must be done on the job, the student will have a strong background in fundamental skills of refrigeration, electricity, mathematics, communication skills, and drafting.

To earn a certificate, students must complete the required courses as listed with a minimum grade of “C.” At least 50% of all course work must be completed at Cypress College.

Required courses are listed in suggested sequence:		Units
AC/R 100 C	Prin. of Thermodynamics and Heat Transfer	3
AC/R 110 C	Air Conditioning I	3
AC/R 120 C	Piping Practice, Tools and Safety	2
AC/R 036 C	Refrigerants, Charging and Recovery	1
AC/R 037 C	Blueprints and Dimension Analysis	2
AC/R 105 C	Electricity for A/C and Refrig I	3
AC/R 115 C	Gas Heating and Carbon Monoxide	3
AC/R 145 C	Load Calcs for Heat and Cool	2
AC/R 106 C	Electricity for A/C and Refrig II	3
AC/R 210 C	Commercial Refrigeration	3
AC/R 220 C	A/C Controls and Energy Mgt.	2
AC/R 230 C	Heat Pumps	2
AC/R 205 C	Commercial Air Conditioning	3
AC/R 215 C	Codes and Estimating for HVACR	3
AC/R 035 C	Building Commissioning	2
AC/R 055 C	Technician Customer Relations	2
AC/R 050 C	HVAC/R Special Projects	.5–1
Total Units		39.5–41

AIR CONDITIONING BUILDING COMMISSIONING CERTIFICATE

Program Code: 1C31185

The Building Commissioning Certificate provides students with a career path for attaining the communication skills, practical knowledge, and technical training necessary for pursuing a career in building commissioning certification. Students completing this certificate will develop an advanced understanding of the building commissioning process. To earn this certificate, complete the required courses as listed with a minimum grade of “C.” At least 50% of all major course work must be completed at Cypress College.

Required courses are listed in suggested sequence:		Units
AC/R 100 C	Prin. of Thermodynamics and Heat Transfer	3
AC/R 110 C	Air Conditioning I	3
AC/R 120 C	Piping Practice, Tools and Safety	2
AC/R 036 C	Refrigerants, Charging and Recovery	1
AC/R 037 C	Blueprints and Dimension Analysis	2
AC/R 105 C	Electricity for A/C and Refrig I	3
AC/R 115 C	Gas Heating and Carbon Monoxide	3
AC/R 125 C	Boiler and Hydronic Heating	2
AC/R 135 C	Solar Energy for Heat and Cool	2
AC/R 145 C	Load Calcs for Heat and Cool	2
AC/R 035 C	Building Commissioning	2
Total Units		25

AIR CONDITIONING CODES AND ESTIMATING CERTIFICATE

Program Code: 1C31106

The Codes and Estimating Certificate provides students with a career path for attaining the communication skills, practical knowledge, and technical training necessary for pursuing a career in building codes and cost estimating. Students completing this certificate will develop an advanced understanding of building codes and cost estimating. To earn this certificate, complete the required courses as listed with a minimum grade of “C.” At least 50% of all major course work must be completed at Cypress College.

Required courses are listed in suggested sequence:		Units
AC/R 037 C	Blueprints and Dimension Analysis	2
AC/R 036 C	Refrigerants, Charging and Recovery	1
AC/R 100 C	Prin. of Thermodynamics and Heat Transfer	3
AC/R 110 C	Air Conditioning I	3
AC/R 105 C	Electricity for A/C and Refrig I	3
AC/R 115 C	Gas Heating and Carbon Monoxide	3
AC/R 125 C	Boiler and Hydronic Heating	2
AC/R 135 C	Solar Energy for Heat and Cool	2
AC/R 145 C	Load Calcs for Heat and Cool	2
AC/R 215 C	Codes and Estimating for HVACR	3
Total Units		24

AIR CONDITIONING COMMERCIAL AIR CONDITIONING CERTIFICATE **Program Code: 1C31186**

The Commercial Air Conditioning Certificate provides students with a career path for attaining the communication skills, practical knowledge, and technical training necessary for pursuing a career in commercial building air conditioning. Students completing this certificate will develop an advanced understanding of commercial building air conditioning. To earn this certificate, complete the required courses as listed with a minimum grade of "C." At least 50% of all major course work must be completed at Cypress College.

Required courses are listed in suggested sequence:		Units
AC/R 100 C	Prin. of Thermodynamics and Heat Transfer	3
AC/R 110 C	Air Conditioning I	3
AC/R 120 C	Piping Practice, Tools and Safety	2
AC/R 036 C	Refrigerants, Charging and Recovery	1
AC/R 037 C	Blueprints and Dimension Analysis	2
AC/R 105 C	Electricity for A/C and Refrig I	3
AC/R 115 C	Gas Heating and Carbon Monoxide	3
AC/R 125 C	Boiler and Hydronic Heating	2
AC/R 135 C	Solar Energy for Heat and Cool	2
AC/R 145 C	Load Calcs for Heat and Cool	2
AC/R 205 C	Commercial Air Conditioning	3
Total Units		26

COMMERCIAL REFRIGERATION CERTIFICATE **Program Code: 1C31171**

The Commercial Refrigeration Certificate provides students with a career path for attaining the communication skills, practical knowledge, and technical training necessary for pursuing a career in Commercial Refrigeration. Students completing this certificate will develop an advanced understanding of commercial refrigeration. To earn this certificate, complete the required courses as listed with a minimum grade of "C." At least 50% of all major course work must be completed at Cypress College.

Required courses are listed in suggested sequence:		Units
AC/R 100 C	Prin. of Thermodynamics and Heat Transfer	3
AC/R 120 C	Piping Practice, Tools and Safety	2
AC/R 036 C	Refrigerants, Charging and Recovery	1
AC/R 037 C	Blueprints and Dimension Analysis	2
AC/R 050 C	HVAC/R Special Projects	.5-1
AC/R 105 C	Electricity for A/C and Refrig I	3
AC/R 106 C	Electricity for A/C and Refrig II	3
AC/R 135 C	Solar Energy for Heat and Cool	2
AC/R 145 C	Load Calcs for Heat and Cool	2
AC/R 210 C	Commercial Refrigeration	3
Total Units		21.5-22

AIR CONDITIONING ENVIRONMENTAL CONTROLS CERTIFICATE **Program Code: 1C31189**

The Controls and Energy Management Certificate provides students with a career path for attaining the communication skills, practical knowledge, and technical training necessary for pursuing a career in controls and energy management. Students completing this certificate will develop an advanced understanding of building controls and energy management. To earn this certificate, complete the required courses as listed with a minimum grade of "C." At least 50% of all major course work must be completed at Cypress College.

Required courses are listed in suggested sequence:		Units
AC/R 100 C	Prin. of Thermodynamics and Heat Transfer	3
AC/R 110 C	Air Conditioning I	3
AC/R 036 C	Refrigerants, Charging and Recovery	1
AC/R 037 C	Blueprints and Dimension Analysis	2
AC/R 050 C	HVAC/R Special Projects	.5-1
AC/R 105 C	Electricity for A/C and Refrig I	3
AC/R 106 C	Electricity for A/C and Refrig II	3
AC/R 115 C	Gas Heating and Carbon Monoxide	3
AC/R 125 C	Boiler and Hydronic Heating	2
AC/R 135 C	Solar Energy for Heat and Cool	2
AC/R 145 C	Load Calcs for Heat and Cool	2
AC/R 220 C	A/C Controls and Energy Mgt.	2
Total Units		26.5-27

AIR CONDITIONING CUSTOMER SERVICE CERTIFICATE **Program Code: 1C31188**

The Customer Service Certificate provides students with a career path for attaining the communication skills, practical knowledge, and technical training necessary for pursuing a career in customer service. Students completing this certificate will develop an advanced understanding of personal inter-relations of customer service. To earn this certificate, complete the required courses as listed with a minimum grade of "C." At least 50% of all major course work must be completed at Cypress College.

Required courses are listed in suggested sequence:		Units
AC/R 100 C	Prin. of Thermodynamics and Heat Transfer	3
AC/R 110 C	Air Conditioning I	3
AC/R 120 C	Piping Practice, Tools and Safety	2
AC/R 036 C	Refrigerants, Charging and Recovery	1
AC/R 037 C	Blueprints and Dimension Analysis	2
AC/R 105 C	Electricity for A/C and Refrig I	3
AC/R 115 C	Gas Heating and Carbon Monoxide	3
AC/R 125 C	Boiler and Hydronic Heating	2
AC/R 135 C	Solar Energy for Heat and Cool	2
AC/R 145 C	Load Calcs for Heat and Cool	2
AC/R 055 C	Technician Customer Relations	2
Total Units		25

GREEN REFRIGERATION CERTIFICATE **Program Code: 1C31191**

The Green Refrigeration Certificate provides students with a career path for attaining the communication skills, practical knowledge, and technical training necessary for pursuing a career in Green Refrigeration. Students completing this certificate will develop an advanced understanding of green refrigeration. To earn this certificate, complete the required courses as listed with a minimum grade of "C." At least 50% of all major course work must be completed at Cypress College.

Required courses are listed in suggested sequence:		Units
AC/R 100 C	Prin. of Thermodynamics and Heat Transfer	3
AC/R 110 C	Air Conditioning I	3
AC/R 120 C	Piping Practice, Tools and Safety	2
AC/R 036 C	Refrigerants, Charging and Recovery	1
AC/R 037 C	Blueprints and Dimension Analysis	2
AC/R 050 C	HVAC/R Special Projects	.5–1
AC/R 105 C	Electricity for A/C and Refrig I	3
AC/R 115 C	Gas Heating and Carbon Monoxide	3
AC/R 125 C	Boiler and Hydronic Heating	2
AC/R 135 C	Solar Energy for Heat and Cool	2
AC/R 145 C	Load Calcs for Heat and Cool	2
AC/R 240 C	Green Refrig and Auditing	2
Total Units		25.5–26

AIR CONDITIONING HEAT PUMP

CERTIFICATE

Program Code: 1C31192

The Heat Pump Certificate provides students with a career path for attaining the communication skills, practical knowledge, and technical training necessary for pursuing a career in Heat Pump Technical Servicing. Students completing this certificate will develop an advanced understanding of heat pump systems. To earn this certificate, complete the required courses as listed with a minimum grade of "C." At least 50% of all major course work must be completed at Cypress College.

Required courses are listed in suggested sequence:		Units
AC/R 100 C	Prin. of Thermodynamics and Heat Transfer	3
AC/R 110 C	Air Conditioning I	3
AC/R 120 C	Piping Practice, Tools and Safety	2
AC/R 036 C	Refrigerants, Charging and Recovery	1
AC/R 037 C	Blueprints and Dimension Analysis	2
AC/R 105 C	Electricity for A/C and Refrig I	3
AC/R 115 C	Gas Heating and Carbon Monoxide	3
AC/R 125 C	Boiler and Hydronic Heating	2
AC/R 135 C	Solar Energy for Heat and Cool	2
AC/R 145 C	Load Calcs for Heat and Cool	2
AC/R 230 C	Heat Pumps	2
Total Units		25

AIR CONDITIONING GREEN AIR CONDITIONING

CERTIFICATE

Program Code: 1C31190

The Green Air Conditioning Certificate provides students with a career path for attaining the communication skills, practical knowledge, and technical training necessary for pursuing a career in Green Air Conditioning. Students completing this certificate will develop an advanced understanding of the Green Air Conditioning process. To earn this certificate, complete the required courses as listed with a minimum grade of "C." At least 50% of all major course work must be completed at Cypress College.

Required courses are listed in suggested sequence:		Units
AC/R 100 C	Prin. of Thermodynamics and Heat Transfer	3
AC/R 110 C	Air Conditioning I	3
AC/R 120 C	Piping Practice, Tools and Safety	2
AC/R 036 C	Refrigerants, Charging and Recov	1
AC/R 037 C	Blueprints and Dimension Analysis	2
AC/R 105 C	Electricity for A/C and Refrig I	3
AC/R 115 C	Gas Heating and Carbon Monoxide	3
AC/R 125 C	Boiler and Hydronic Heating	2
AC/R 135 C	Solar Energy for Heat and Cool	2
AC/R 145 C	Load Calcs for Heat and Cool	2
AC/R 225 C	Green A/C and Auditing	2
Total Units		25

INDUSTRIAL TECHNOLOGY TRANSFER PROGRAM

AIR CONDITIONING SYSTEMS OPTION

Students should consult a counselor or www.assist.org for lower division major requirements for most California public universities. (See the Standard Definitions section of the catalog for a description of ASSIST.) Students transferring to an independent college/university should consult the catalog of the individual school and a counselor for lower division major requirements.

Air Conditioning and Refrigeration (AC/R)

AC/R 035 C Building Commissioning

2 Units

Advisory: AC/R 105 C.

Term hours: 24–27 lecture and 24–27 laboratory. This course is designed to instruct the student in the verification of new construction, that all the subsystems for HVAC, Plumbing, Electrical, Building Envelopes, Interior Systems (example laboratory units), cogeneration, utility plants, sustainable systems, Lighting, Controls and provide sustainable life cost energy savings.

AC/R 036 C Refrigerants, Charging and Recovery

1 Unit

Term hours: 24–27 lecture and 24–27 laboratory. This course examines refrigerant classification, physical and chemical properties, lubricants, proper and safe handling, refrigerant systems evacuation, charging and recovery with classroom lecture, demonstration and laboratory exercises. Students may take an optional EPA refrigerant and R-410A certification exam.

AC/R 037 C Blueprints and Dimension Analysis

2 Units

Term hours: 24–27 lecture and 24–27 laboratory. This course covers the application of engineering calculations and elements of blueprint reading as encountered by the air conditioning and refrigeration field technician, project manager and design engineer. Course includes practical application of numbers to the topics of problem solving, dimension conversion and mathematical verification, proportions and ratios, length measurements with field application and exercises, area calculations, duct and sheet metal calculations, equivalent units of temperature measurement, discounting and field cost estimation.

AC/R 050 C HVAC/R Special Projects

.5 to 1 Units

Term hours: 24–54 laboratory depending on units desired. This course is designed for students who have demonstrated interest and competencies for increased knowledge and experience in air conditioning and refrigeration technologies and applications not ordinarily covered in the curriculum. Students will participate in independent study and/or research on selected or assigned projects. May be taken for credit 3 times.

AC/R 055 C Technician Customer Relations

2 Units

Term hours: 24–27 lecture and 24–27 laboratory. This course provides guidelines and best practices for providing excellent field service customer relations that will enable front-line technicians and service staff in back-up and support roles to build, maintain, and increase a loyal customer base.

AC/R 100 C Principles of Thermodynamics and Heat Transfer

3 Units

Advisory: AC/R 120 C.

Term hours: 24–27 lecture and 72–81 laboratory. This course is a basic study of the theory of thermodynamics and heat transfer as applied to mechanical vapor compression refrigeration cycle and system components. Classes include lectures with practical demonstrations and hands-on experience including laboratory projects demonstrate heat transfer theories and vapor compression mechanical system cycle components and accessories. (CSU)

AC/R 105 C Electricity for A/C and Refrigeration I 3 Units

Term hours: 24–27 lecture and 72–81 laboratory. This course includes the basic electrical theory, concepts and principles as applied to air conditioning and refrigeration. Schematic reading and drawing, with laboratory project applications involving circuit wiring, the measurement of electrical quantities with electrical meters and electrical safety, will be presented. (CSU)

AC/R 106 C Electricity for Air Conditioning and Refrigeration II 3 Units

Prerequisite: AC/R 105 C with a minimum grade of "C."

Term hours: 24–27 lecture and 72–81 laboratory. This course is a continuation of Electricity for Air Conditioning and Refrigeration which builds upon the principles learned and applied. Course includes single phase, three phase electric motors and ECM motors, circuit board troubleshooting, overloads, pressure controls, time clocks and autotransformers with a lecture and laboratory practice exercises. (CSU)

AC/R 110 C Air Conditioning I 3 Units

Term hours: 24–27 lecture and 72–81 laboratory. This course is an introduction into comfort cooling and air conditioning applications with a study of the behavior of air vapor mixtures as applied to the psychrometric chart and related to the design of duct systems, emphasizing duct sizing, air distribution, fans and sheet metal techniques, as it relates to indoor air quality. (CSU)

AC/R 115 C Gas Heating and Carbon Monoxide 3 Units

Term hours: 24–27 lecture and 72–81 laboratory. This course is a basic study of gas heating systems which include the principles of fuel combustion, combustion analysis and forced warmer air heat. Carbon monoxide and the effects of incomplete combustion will be studied and analyzed. (CSU)

AC/R 120 C Piping Practice, Tools and Safety 2 Units

Advisory: AC/R 100 C.

Term hours 24–27 lecture and 24–27 laboratory. This course includes laboratory projects and demonstrations involving design and construction of system piping, including techniques of shaping, forming, soldering, welding and the tools and safe practices required to design and construct refrigerant piping systems. (CSU)

AC/R 125 C Boiler and Hydronic Heating 2 Units

Term hours 24–27 lecture and 24–27 laboratory. This course includes lectures and laboratory projects involving the design, assembly, and operation of hot water boilers, hot water piping distribution (hydronic), and associated controls and control valves. Included in the course content is the proper use of the related tools and safety. (CSU)

AC/R 130 C Pneumatic Control for A/C 4 Units

Advisory: Completion of or concurrent enrollment in AC/R 111 C, AC/R 112 C, MATH 020 C.

Term hours: 48–54 lecture and 48–54 laboratory. A course designed to instruct the students in the application of air conditioning pneumatic controls as is used in commercial building systems. Students will apply the theories and skills taught in the classroom on laboratory mock-ups simulating industry standards. (CSU)

AC/R 135 C Solar Energy for Heat and Cool 2 Units

Term hours: 24–27 lecture and 24–27 laboratory. This course includes lectures and laboratory projects and demonstrations involving design, assembly and operation of solar energy systems. Included in this course content is theory and application of passive solar heating and cooling, solar energy systems using photo-voltaic arrays, thermal heating arrays, and new, cutting edge solar technologies. Also included is a through discussion of the various tools and safe practices associated with solar energy systems. (CSU)

AC/R 140 C Plumbing Principles/Practices 4 Units

Term hours 48–54 lecture and 48–54 laboratory. A course designed to instruct the student in the application of plumbing technology as is used in commercial building systems. Students will apply the theories and skills taught in the classroom on laboratory mock-ups simulating industry standards. (CSU)

AC/R 145 C Load Calculation for Heat and Cool 2 Units

Prerequisite: AC/R 110 C with a minimum grade of "C."

Term hours 24–27 lecture and 24–27 laboratory. This is an advanced air conditioning class in which the student will learn how to calculate the heating and cooling load of a building. The student will also create a computer spreadsheet to calculate the heat and cooling load. This course will also introduced the student to industry standards computer software that will calculate the heating and cooling load. (CSU)

AC/R 205 C Commercial Air Conditioning 3 Units

Advisory: AC/R 105 C.

Term hours: 24–27 lecture and 72–81 laboratory. This is an advanced course with emphasis on the air conditioning cycle. Pipe sizing, absorption systems, centrifugal and screw chillers, cooling towers, air handlers, and chilled water pumping. (CSU)

AC/R 210 C Commercial Refrigeration 3 Units

Advisory: AC/R 100 C.

Term hours: 24–27 lecture and 72–81 laboratory. This is an advanced course with emphasis on the refrigeration cycle. Pipe sizing, compressor sizing, h.p. requirements, single and two stage refrigeration systems and other advanced refrigeration systems will be included. (CSU)

AC/R 215 C Codes and Estimating for HVACR 3 Units

Advisory: AC/R 105 C.

Term hours: 24–27 lecture and 72–81 laboratory. This course is an lab class in which the student will develop a material and labor cost estimate and prepare construction bids for air conditioning systems. Building and mechanical codes and inspection procedures will be covered. Estimating processes by spreadsheet will be introduced. (CSU)

AC/R 220 C Controls and Energy Mgt. 2 Units

Advisory: AC/R 100 C.

Term hours: 24–27 lecture and 24–27 laboratory. A course designed to instruct the students in the application of air conditioning pneumatic and Direct Digital controls as is used in commercial building systems. Students will apply the theories and skills taught in the classroom on laboratory mock-ups simulating industry standards. (CSU)

AC/R 225 C Green A/C and Auditing 2 Units

Advisory: AC/R 105 C.

Term hours: 24–27 lecture and 24–27 laboratory. This course is designed to instruct the student in the design, application and maintenance of highly energy efficient (GREEN) air conditioning systems. Including topics on refrigerants, carbon footprint and efficient systems for commercial applications. (CSU)

AC/R 230 C Heat Pumps 2 Units

Prerequisite: AC/R 100 C and AC/R 105 C with minimum grades of "C."

Term hours: 24–27 lecture and 24–27 laboratory. This course is designed to instruct the student in the application of heat pumps in commercial building systems. Students will apply the theories and skills taught in the classroom on laboratory mock-ups simulating industry standards. (CSU)

AC/R 240 C Green Refrigeration and Auditing 2 Units*Advisory: AC/R 100 C.*

Term hours: 24–27 lecture and 24–27 laboratory. This course is designed to instruct the student in the design, application and maintenance of highly energy efficient (GREEN) refrigeration systems. Including topics related to ammonia and carbon dioxide refrigeration systems for commercial applications. (CSU)

AC/R 298 C A/C Refrigeration Seminar .5 to 12 Units*Prerequisite: May be required.**Corequisite: May be required.**Advisory: May be required.*

Term hours: 0–12 lecture and/or 0–36 laboratory. This is a course for students who wish to increase their knowledge of air conditioning and refrigeration. Various topics will be offered. Unit credit may range from .5 to 12 units in any given semester. Consult the class schedule to verify credit for a particular semester. May be taken for credit 1–4 times. Pass/No Pass or Pass/No Pass/Letter Grade Option or Standard Letter Grade. Fees may be required — Payable at Registration. (CSU)

Airline and Travel Careers

Division of Career Technical Education

Division Dean — Steve Donley*Faculty*

Kathleen Reiland

Counselor

Jane Jepson

PROGRAM LEARNING OUTCOMES (PLOs)

Airline and Travel Careers

Students who receive a certificate from the Cypress College Airline and Travel Careers Program

- Will have acquired the specified set of skills required for airline/travel employment opportunities
- Will have achieved the necessary competencies to enter the airline, cruise, travel, tourism fields
- Will be aware of additional educational and career opportunities within the above industries

AIRLINE AND TRAVEL CAREERS PROGRAM

The Airline and Travel Careers Program provides students with a career path for attaining the communication skills, practical knowledge, and technical training necessary to work in the airline, cruise, and travel industries.

Associate in Science Degree:

Airline Customer Services

*Aviation Management

Flight Attendant

Travel/Tourism

Certificates:

Advanced Airline Customer Services

Advanced Flight Attendant

Advanced Travel/Tourism

*Aviation Management

Basic Airline Customer Services

Basic Flight Attendant

Basic Travel/Tourism

Ancillary Certificates:

Basic Cruise Line Sales and Operations

Basic Tourism and Conference Management

Homeland Transportation Certificate

*Interdisciplinary programs refer to Aviation Department Section

ASSOCIATE IN SCIENCE DEGREE AIRLINE CUSTOMER SERVICES Program Code: 1S14040

The Airline Customer Services Program provides students with a career path for attaining the communication skills, practical knowledge, and technical training necessary for pursuing a career as a reservations agent, gate agent, ticket agent, or customer services manager. Students completing this degree will develop an advanced understanding of the airline industry and the safety, security, and service requirements necessary to work in customer services for a major airline.

To earn an Associate Degree students must complete: (1) all major course requirements with a minimum grade of "C"; (2) 25 units of General Education Graduation Requirements; (3) the cultural diversity and reading requirements; (4) any elective courses to complete a minimum of 60 units; and, (5) have a minimum GPA of 2.0. At least 50% of all major course work must be completed at Cypress College. Courses that fulfill major requirements for an Associate Degree at Cypress College might not be the same as those required for completing the major at a transfer institution offering a Baccalaureate Degree. For information on specific university requirements, please consult with your counselor, or visit the Transfer Center.

Required courses are listed in numeric sequence:		Units
ATC 101 C	Intro to Travel Careers	3
ATC 102 C	Career Communication/Portfolio	3
ATC 174 C	Destinations: Americas/Europe	3
ATC 175 C	Destinations: Africa/Pacific	3
ATC 182 C	Cultural Tourism	3
ATC 183 C	Customer Care: Airline/Travel	3
ATC 191 C	Airline Reservations: APOLLO	3
ATC 192 C	Airline Reservations: SABRE	3
ATC 270 C	Airline Operations	3

Electives: To complete all major course requirements, students must complete 8 elective units from the list below for a total of 35 units.

	Units
ATC 112 C	Homeland Security 3
ATC 114 C	Investigative Documentation 3
ATC 116 C	Aviation/Trans Security 3
ATC 123 C	Travel Sales and Tour Operations 3
ATC 126 C	Travel Management 3
ATC 256 C	Crew Resource Management 3
ATC 278 C	Public Relations 3
ATC 295 C	Airline/Travel Internship 3
ATC 298 C	Airline/Travel Seminar .5–12
ATC 299 C	Independent Study .5–2
AVIA 132 C	Private Pilot 4
Total Units	35

ADVANCED AIRLINE CUSTOMER SERVICES CERTIFICATE Program Code: 1C21124

The Airline Customer Services Program provides students with a career path for attaining the communication skills, practical knowledge, and technical training necessary for pursuing a career as a reservations agent, gate agent, ticket agent, or customer services manager. Students completing this certificate will develop an advanced understanding of the airline industry and the safety, security, and service requirements necessary to work in customer services for a major airline.

To earn this certificate, complete the required courses as listed with a minimum grade of “C.” At least 50% of all major course work must be completed at Cypress College.

Required courses are listed in numeric sequence:

	Units
ATC 101 C	Intro to Travel Careers 3
ATC 102 C	Career Communication/Portfolio 3
ATC 174 C	Destinations: Americas/Europe 3
ATC 175 C	Destinations: Africa/Pacific 3
ATC 182 C	Cultural Tourism 3
ATC 183 C	Customer Care: Airline/Travel 3
ATC 191 C	Airline Reservations: APOLLO 3
ATC 192 C	Airline Reservations: SABRE 3
ATC 270 C	Airline Operations 3

Electives: To complete all major course requirements, students must complete 8 elective units from the list below for a total of 35 units.

	Units
ATC 112 C	Homeland Security 3
ATC 114 C	Investigative Documentation 3
ATC 116 C	Aviation/Trans Security 3
ATC 123 C	Travel Sales and Tour Operations 3
ATC 126 C	Travel Management 3
ATC 256 C	Crew Resource Management 3
ATC 278 C	Public Relations 3
ATC 295 C	Airline/Travel Internship 3
ATC 298 C	Airline/Travel Seminar .5–12
ATC 299 C	Independent Study .5–2
AVIA 132 C	Private Pilot 4
Total Units	35

BASIC AIRLINE CUSTOMER SERVICES CERTIFICATE Program Code: 1K14403

The Airline Customer Services Program provides students with a career path for attaining the communication skills, practical knowledge, and technical training necessary for pursuing a career as a reservations agent, gate agent, ticket agent, or customer services manager. Students completing this degree will develop a basic understanding of the airline industry and the safety, security, and service requirements necessary to work in customer services for a major airline.

Students may earn a Basic Airline Customer Services Certificate (12 units), which will prepare them to pursue working in the airline customer services industry as an intern.

To earn a Basic Airline Customer Services Certificate, students must complete the required courses as listed with a minimum grade of “C.” At least 50% of all course work must be completed at Cypress College.

Required courses are listed in numeric sequence:

Course#	Title	Units
ATC 101 C	Intro to Travel Careers	3
ATC 102 C	Career Communication/Portfolio	3
ATC 174 C	Destinations: Americas/Europe	3
	or	
ATC 175 C	Destinations: Africa/Pacific	(3)
ATC 191 C	Airline Reservations: APOLLO	3
	or	
ATC 192 C	Airline Reservations: SABRE	(3)
ATC 270 C	Airline Operations	3
	Total Units Required	15

ASSOCIATE IN SCIENCE DEGREE FLIGHT ATTENDANT Program Code: 1S03814

The Flight Attendant Program provides students with a career path for attaining the communication skills, practical knowledge, and technical training necessary for pursuing a career as a flight attendant. Students completing this degree will develop an advanced understanding of the airline industry and the customer safety, security, and service requirements necessary to work as a flight attendant for a major airline.

To earn an Associate Degree students must complete: (1) all major course requirements with a minimum grade of “C”; (2) 25 units of General Education Graduation Requirements; (3) the cultural diversity and reading requirements; (4) any elective courses to complete a minimum of 60 units; and, (5) have a minimum GPA of 2.0. At least 50% of all major course work must be completed at Cypress College. Courses that fulfill major requirements for an Associate Degree at Cypress College might not be the same as those required for completing the major at a transfer institution offering a Baccalaureate Degree. For information on specific university requirements, please consult with your counselor, or visit the Transfer Center.

Required courses are listed in suggested sequence:

	Units
ATC 101 C	Intro to Travel Careers 3
ATC 102 C	Career Communication/Portfolio 3
ATC 174 C	Destinations: Americas/Europe 3
ATC 175 C	Destinations: Africa/Pacific 3
ATC 182 C	Cultural Tourism 3
ATC 183 C	Customer Care: Airline/Travel 3
ATC 256 C	Crew Resource Management 3
ATC 270 C	Airline Operations 3
ATC 274 C	Passenger Services and Safety 3

Electives: To complete all major course requirements, students must complete 8 elective units from the list below for a total of 35 units.

		Units
ATC 114 C	Investigative Documentation	3
ATC 116 C	Aviation/Trans Security	3
ATC 123 C	Travel Sales and Tour Operations	3
ATC 126 C	Travel Management	3
ATC 278 C	Public Relations	3
ATC 295 C	Airline/Travel Internship	3
ATC 298 C	Airline/Travel Seminar	.5–12
ATC 299 C	Independent Study	.5–2
AVIA 100 C	Introduction to Aviation	3
AVIA 132 C	Private Pilot	4
PE 170 C	Self Defense	.5–1
PE 235 C	First Aid, CPR and Emergencies	3
ATC 112 C	Homeland Security	3
	Total Units	35

ADVANCED FLIGHT ATTENDANT CERTIFICATE Program Code: 1C21126

The Flight Attendant Program provides students with a career path for attaining the communication skills, practical knowledge, and technical training necessary for pursuing a career as a flight attendant. Students completing this certificate will develop an advanced understanding of the airline industry and the customer safety, security, and service requirements necessary to work as a flight attendant for a major airline. To earn this certificate, complete the required courses as listed with a minimum grade of "C." At least 50% of all major course work must be completed at Cypress College.

Required courses are listed in suggested sequence:		Units
ATC 101 C	Intro to Travel Careers	3
ATC 102 C	Career Communication/Portfolio	3
ATC 174 C	Destinations: Americas/Europe	3
ATC 175 C	Destinations: Africa/Pacific	3
ATC 182 C	Cultural Tourism	3
ATC 183 C	Customer Care: Airline/Travel	3
ATC 256 C	Crew Resource Management	3
ATC 270 C	Airline Operations	3
ATC 274 C	Passenger Services and Safety	3

Electives: To complete all major course requirements, students must complete 8 elective units from the list below for a total of 35 units.

		Units
ATC 112 C	Homeland Security	3
ATC 114 C	Investigative Documentation	3
ATC 116 C	Aviation/Trans Security	3
ATC 123 C	Travel Sales and Tour Operations	3
ATC 126 C	Travel Management	3
ATC 278 C	Public Relations	3
ATC 295 C	Airline/Travel Internship	3
ATC 298 C	Airline/Travel Seminar	.5–12
ATC 299 C	Independent Study	.5–2
AVIA 100 C	Introduction to Aviation	3
AVIA 132 C	Private Pilot	4
PE 170 C	Self Defense	.5–1
PE 235 C	First Aid, CPR and Emergencies	3
	Total Units	35

BASIC FLIGHT ATTENDANT CERTIFICATE Program Code: 1K14404

The Flight Attendant Program provides students with a career path for attaining the communication skills, practical knowledge, and technical training necessary for pursuing a career as a flight attendant. Students completing this certificate will develop a basic understanding of the airline industry and the customer safety, security, and service requirements necessary to work as a flight attendant for a major airline.

To earn a Basic Flight Attendant Certificate, students must complete the required courses as listed with a minimum grade of "C." At least 50% of all course work must be completed at Cypress College.

Required courses are listed in numeric sequence:

Course#	Title	Units
ATC 101 C	Intro to Travel Careers	3
ATC 102 C	Career Communication/Portfolio	3
ATC 174 C	Destinations: Americas/Europe	3
	or	
ATC 175 C	Destinations: Africa/Pacific	(3)
ATC 183 C	Customer Care: Airline/Travel	3
ATC 270 C	Airline Operations	3
	or	
ATC 274 C	Passenger Services and Safety	(3)
	Total Units Required	15

ASSOCIATE IN SCIENCE DEGREE TRAVEL/TOURISM Program Code: 1S07859

The Travel and Tourism Program provides students with a career path for attaining the communication skills, practical knowledge, and technical training necessary for pursuing a career as a travel agent, tour guide, or corporate travel consultant. Students completing this degree will develop an advanced understanding of the travel industry and the sales, security, and service requirements necessary to work in the travel industry. To earn an Associate Degree students must complete: (1) all major course requirements with a minimum grade of "C"; (2) 25 units of General Education Graduation Requirements; (3) the cultural diversity and reading requirements; (4) any elective courses to complete a minimum of 60 units; and, (5) have a minimum GPA of 2.0. At least 50% of all major course work must be completed at Cypress College. Courses that fulfill major requirements for an Associate Degree at Cypress College might not be the same as those required for completing the major at a transfer institution offering a Baccalaureate Degree. For information on specific university requirements, please consult with your counselor, or visit the Transfer Center.

Required courses are listed in suggested sequence:		Units
ATC 101 C	Intro to Travel Careers	3
ATC 102 C	Career Communication/Portfolio	3
ATC 123 C	Travel Sales and Tour Operations	3
ATC 126 C	Travel Management	3
ATC 174 C	Destinations: Americas/Europe	3
ATC 175 C	Destinations: Africa/Pacific	3
ATC 182 C	Cultural Tourism	3
ATC 191 C	Airline Reservations: APOLLO	3
ATC 192 C	Airline Reservations: SABRE	3
ATC 223 C	Cruise Line Sales and Operations	3

Electives: To complete all major course requirements, students must complete 5 elective units from the list below for a total of 35 units.

	Units
ATC 112 C Homeland Security	3
ATC 114 C Investigative Documentation	3
ATC 116 C Aviation/Trans Security	3
ATC 180 C Tourism/Conference Management	3
ATC 183 C Customer Care: Airline/Travel	3
ATC 278 C Public Relations	3
ATC 295 C Airline/Travel Internship	3
ATC 298 C Airline/Travel Seminar	.5–12
ATC 299 C Independent Study	.5–2
Total Units	35

ADVANCED TRAVEL/TOURISM CERTIFICATE Program Code: 1C21123

The Travel and Tourism Program provides students with a career path for attaining the communication skills, practical knowledge, and technical training necessary for pursuing a career as a travel agent, tour guide, or corporate travel consultant. Students completing this certificate will develop an advanced understanding of the travel industry and the sales, security, and service requirements necessary to work in the travel industry. To earn this certificate, complete the required courses as listed with a minimum grade of “C.” At least 50% of all major course work must be completed at Cypress College.

Required courses are listed in suggested sequence:

	Units
ATC 101 C Intro to Travel Careers	3
ATC 102 C Career Communication/Portfolio	3
ATC 123 C Travel Sales and Tour Operations	3
ATC 126 C Travel Management	3
ATC 174 C Destinations: Americas/Europe	3
ATC 175 C Destinations: Africa/Pacific	3
ATC 182 C Cultural Tourism	3
ATC 191 C Airline Reservations: APOLLO	3
ATC 192 C Airline Reservations: SABRE	3
ATC 223 C Cruise Line Sales and Operations	3

Electives: To complete all major course requirements, students must complete 5 elective units from the list below for a total of 35 units.

ATC 112 C Homeland Security	3
ATC 114 C Investigative Documentation	3
ATC 116 C Aviation/Trans Security	3
ATC 180 C Tourism/Conference Management	3
ATC 183 C Customer Care: Airline/Travel	3
ATC 278 C Public Relations	3
ATC 295 C Airline/Travel Internship	3
ATC 298 C Airline/Travel Seminar	.5–12
ATC 299 C Independent Study	.5–2
Total Units	35

BASIC TRAVEL/TOURISM CERTIFICATE Program Code: 1K14405

The Travel and Tourism Program provides students with a career path for attaining the communication skills, practical knowledge, and technical training necessary for pursuing a career as a travel agent, tour guide, or corporate travel consultant. Students completing this certificate will develop a basic understanding of the travel industry and the sales, security, and service requirements necessary to work in the travel industry.

To earn a Travel/Tourism Certificate, students must complete the required courses with a minimum grade of “C.” At least 50% of all course work must be completed at Cypress College.

Required courses are listed in suggested sequence:

Course #	Title	Units
ATC 101 C	Intro to Travel Careers	3
ATC 102 C	Career Communication/Portfolio	3
ATC 123 C	Travel Sales and Tour Operations	3
ATC 174 C	Destinations: Americas/Europe	3
	or	
ATC 175 C	Destinations: Africa/Pacific	(3)
ATC 191 C	Airline Reservations: APOLLO	3
	or	
ATC 192 C	Airline Reservations: SABRE	(3)
Total Units Required		15

BASIC CRUISE LINE SALES AND OPERATIONS CERTIFICATE Program Code: 1K30458

The Basic Cruise Line Sales and Operations Certificate provides students with a career path for attaining the communication skills, practical knowledge, and technical training necessary for pursuing a career in cruise line sales and operations. Students completing this certificate will develop a basic understanding of the cruise line operations and the sales, security, and service requirements necessary to work in the cruise industry. To earn this certificate, complete the required courses as listed with a minimum grade of “C.” At least 50% of all major course work must be completed at Cypress College.

Required courses are listed in numeric sequence:

Course#	Title	Units
ATC 101 C	Intro to Travel Careers	3
ATC 102 C	Career Communication/Portfolio	3
ATC 123 C	Travel Sales and Tour Operations	3
ATC 174 C	Destinations: Americas/Europe	3
	or	
ATC 175 C	Destinations: Africa/Pacific	(3)
ATC 223 C	Cruise Line Sales and Operations	3
Total Units Required		15

BASIC TOURISM AND CONFERENCE MANAGEMENT CERTIFICATE Program Code: 1K17168

The Basic Tourism and Conference Management Certificate prepares students to work as professional meeting and event coordinators. The basic certificate will prepare the students for entry-level employment in the industry as an apprentice meeting and event coordinator.

To earn a certificate, students must complete the required courses with a minimum grade of “C.” At least 50% of all course work must be completed at Cypress College.

Required courses are listed in suggested sequence:

Course #	Title	Units
ATC 101 C	Intro to Travel Careers	3
ATC 102 C	Career Communication/Portfolio	3
ATC 123 C	Travel Sales and Tour Operations	3
ATC 180 C	Tourism/Conference Management	3
ATC 174 C	Destinations: Americas/Europe	3
	or	
ATC 175 C	Destinations: Africa/Pacific	(3)
Total Units Required		15

HOMELAND TRANSPORTATION SECURITY CERTIFICATE

Program Code: 1K17169

The Homeland Transportation Security Certificate provides technical skills and in-depth knowledge relating to the homeland security, administration of justice, organizational protection, and safety with an emphasis on the travel and transportation industries.

To earn a certificate, students must complete the required courses with a minimum grade of “C.” At least 50% of all course work must be completed at Cypress College.

Required courses are listed in suggested sequence:

Course #	Title	Units
AJ 100 C	Intro to Law Enforcement or Criminal Law	3 (3)
AJ 110AC	Criminal Law	(3)
ATC 102 C	Career Communication/Portfolio	3
ATC 112 C	Homeland Security	3
ATC 114 C	Investigative Documentation	3
ATC 116 C	Aviation/Trans Security or Disaster Preparedness/Response	3 (3)
ATC 118 C	Disaster Preparedness/Response	(3)
Total Units Required		15

AIRLINE AND TRAVEL CAREERS TRANSFER PROGRAMS

Students should consult a counselor or www.assist.org for lower division major requirements for most California public universities. (See the Standard Definitions section of the catalog for a description of ASSIST.) Students transferring to an independent college/university should consult the catalog of the individual school and a counselor for lower division major requirements.

Airline and Travel Careers (ATC)

ATC 050 C Special Projects — Airline 2 Units

Corequisite: Completion of, or concurrent enrollment in ATC 102 C.

Advisory: Concurrent enrollment in ATC 270 C or ATC 274 C.

Term hours: 16–18 lecture and 48–54 laboratory TBA. This course provides students with service learning opportunities that put into practice the abstract theories of their course work. Students will develop their public contact and customer care skills as they host various campus, community, civic, and travel-related events. Service learning offers students an opportunity to improve their self-directed and critical thinking skills — abilities considered essential in the airline and travel industries. To prepare for industry employment, students will update their career portfolios and practice interviewing on video. May be taken for credit 2 times.

ATC 101 C Introduction to Travel Careers 3 Units

Term hours: 48–54 lecture. This course introduces students to operations and career opportunities in the airline and travel industries. The history, definition, organization, and industry trends will be reviewed. Internet research will be utilized and students will prepare a personalized career project. (CSU)

ATC 102 C Career Communication/Portfolio 3 Units

Term hours: 48–54. Students will learn how professional presentation skills can make the difference in achieving their personal career success. This course reviews both oral and written career communication skills, including the development of a comprehensive resume, cover letter, business writing samples, interviewing skills, technology basics, business etiquette, and a career portfolio. Video will be used to help students achieve maximum effectiveness in mock-interviews. Students will also learn test-taking strategies necessary for career success. Duplicate credit not granted for AVIA 102 C. (CSU)

ATC 103 C Airline/Travel Open Lab .5 to 3 Units

Corequisite: Students must be enrolled in another Airline and Travel Careers course.

Term hours: 27 to 162 laboratory depending on units attempted. This open-entry, open-exit course with flexible hours and variable units provides students enrolled in an Airline and Travel Careers course with the equipment and resources to allow self-paced individualized instruction and/or practice in core competencies. Twenty-seven (27) hours are required for each one-half unit. May be taken for credit 4 times. Open Entry/Open Exit. Pass/No Pass only. \$5.00 Material Fee — Payable at Registration.

ATC 112 C Homeland Security 3 Units

Term hours: 48–54 lecture. This course is an introductory study of domestic and international threats of terrorism. It examines the concepts, definitions, and contemporary issues of modern terrorism. The course includes law enforcement issues for first-responders relating to terrorism, particularly with regard to Homeland Protection and counter terrorists measures. (CSU)

ATC 114 C Investigative Documentation 3 Units

Term hours: 48–54 lecture. This course is an introductory study of the investigation and techniques used to complete accurate and detailed informational reports relating to actual or suspected terrorist activities. The focus of the course is to develop an understanding of how to take accurate notes, prepare reports and formulate investigative techniques. Practical exercises will teach students to employ effective methods of obtaining information from victims, witnesses, and suspects and reporting that information. (CSU)

ATC 116 C Aviation/Trans Security 3 Units

Term hours: 48–54 lecture. This course is an introductory study of domestic and international airport and transportation security issues. It includes the Patriot Act and changing laws relating to airport and transportation security. The course will present and analyze the current status of aviation law pertaining to terrorism, air rage, search and seizure protections and impending changes to the nation's transportation industry. (CSU)

ATC 118 C Disaster Preparedness/Response 3 Units

Term hours: 48–54 lecture. This course provides students with an awareness of natural and man-made incidents which result in catastrophic loss. Disaster scenarios will be examined from the perspective of preparedness, response and clean-up. Federal, state and local response preparedness programs will be a focus, including REMA. Students will take part in simulated incidents, including safety and security for large-scale events. State and national incident command systems, S.E.M.S. and N.I.M.S., will be taught so as to familiarize the student to police and fire responses. Pass/No Pass/Letter Grade Option. (CSU)

ATC 123 C Travel Sales and Tour Operations 3 Units

Term hours: 48–54 lecture. Students will learn the essentials of travel sales and tour operations, including the latest trends, itinerary planning, and the technologies available to travel/tourism consultants in the leisure, recreational, and corporate travel markets. (CSU)

ATC 126 C Travel Management 3 Units

Term hours: 48–54 lecture. This course is a study of management practices in the airline and travel/tourism industries, including ARC requirements, location and staffing, sales reports and agency accounting. Travel markets, product lines, marketing techniques, advertising, and promotions are explored. Techniques for personal and telephone selling and guidelines for handling job stress, sales, and client crises are included. Students will learn supervisory and leadership strategies. (CSU)

ATC 174 C Destinations: Americas/Europe 3 Units

Term hours: 48–54 lecture. This course introduces students to world geography from a travel and tourism perspective. Students will learn about domestic and international travel considerations including itineraries, currencies, travel documents, customs, language, health requirements, and time considerations for locations throughout the Americas and Europe. (CSU)

ATC 175 C Destinations: Africa/Pacific 3 Units

Term hours: 48–54 lecture. This course continues the study of world geography from a travel and tourism perspective. Students will examine international travel considerations including itineraries, currencies, travel documents, customs, language, health requirements, and time considerations for the following locations: Africa, the Middle East, Asia, and the Pacific Islands. (CSU)

ATC 180 C Tourism/Conference Management 3 Units

Term hours: 48–54 lecture. This course is an introductory study of meeting, convention, and event planning. It introduces students to industry terminology, types of events and venues, needs assessments, program and budget development, and project coordination. (CSU)

ATC 182 C Cultural Tourism 3 Units

Term hours: 48–54 lecture. This course examines the implications of cultural tourism in the United States. The course will consider the struggle of people to preserve their cultural identity relative to the role of the U.S. tourism industry in protecting cultural heritage, resources, and sites. The course promotes multicultural awareness, hospitality, and sensitivity as a means of recognizing others and minimizing the exploitation of their culture. The course explores the complexities and challenges of U.S. policy making and preservation in cultural tourism development. (CSU, CUL DIV)

ATC 183 C Customer Care: Airline/Travel 3 Units

Term hours 48–54 lecture. This course examines the priority of customer service and satisfaction in the competitive airline industry. Topics include the safety regulations and service standards of the Federal Aviation Administration, the Department of Transportation, and airlines themselves. Students will study these standards in relation to current performance, public opinion, and service ideology. Students will also investigate how airlines differentiate their service to be competitive in a particular market niche. Students will “shop” airlines and service related businesses to gain tools for developing a personal approach to customer care. (CSU)

ATC 191 C Airline Reservations: APOLLO 3 Units

Term hours: 32–36 lecture and 48–54 laboratory. This course is an introduction to APOLLO, the computer reservations system used by United Airlines and one of the two major systems used by travel consultants. Students will learn how to build PNR's (passenger name records), quote fares, and calculate prices through hands-on applications on computers. \$4.00 Material Fee — Payable at Registration. (Credit by Examination) (CSU)

ATC 192 C Airline Reservations: SABRE 3 Units

Term hours: 32–36 lecture and 48–54 laboratory. This course is an introduction to SABRE, the computer reservations system used by American Airlines and one of the two major systems used by travel consultants. Students will learn how to build PNR's (passenger name records), quote fares, and calculate prices through hands-on applications on computers. \$4.00 Material Fee — Payable at Registration. (CSU)

ATC 210 C Cabin Safety Simulation .5 Units

Advisory: Completion of, or concurrent enrollment in, ATC 270 C or ATC 274 C.

Term hours: 8–9 lecture. Students will receive hands-on instruction in a motion-based aircraft cabin simulator at the Alteon Training facility at the Long Beach Airport. Students will participate in passenger safety training in a simulated aircraft environment. An Alteon Certificate will be issued upon successful completion. A required 3-hour preparatory class will be held on campus and the remaining 6 hours will be delivered at Alteon Training at Long Beach Airport. May be taken for credit 4 times. Facility Use Fee of \$100 required — Payable at Registration. Fee subject to change by facility. (CSU)

ATC 223 C Cruise Line Sales and Operations 3 Units

Term hours: 48–54 lecture. This course provides students with a practical, working knowledge of the cruise industry, including its operation, terminology, associations, and resources. Students will learn how to differentiate, price, market, and sell cruises. Pass/No Pass/Letter Grade Option. (CSU)

ATC 256 C Crew Resource Management 3 Units

Term hours: 48–54 lecture. This course will examine the concepts of Crew Resource Management (CRM) and Human Factors and Aeronautical Decision Making currently practiced in commercial and corporate aviation. The role of crew supervision and training, leadership styles and management oversight will be studied. Single and multi-crew aircraft situations will be studied. Human factors research and aircraft accident investigations will be examined. Duplicate credit not granted for AVIA 256 C. (CSU)

ATC 270 C Airline Operations 3 Units

Term hours: 48–54 lecture. This course is designed for students interested in working in the airline industry as flight attendants or customer service representatives (i.e. ground, reservations, ramp, or ticketing agents). Students will learn airline terminology, city codes, the 24-hour clock, airline operations, and industry hiring standards. (CSU)

ATC 274 C Passenger Services and Safety 3 Units

Advisory: Concurrent enrollment in ATC 050 C recommended.

Term hours: 48–54 lecture. In this course special emphasis is placed on emergency procedures and federal regulations. The essential professional attitude and teamwork needed to successfully perform as a crew member to insure onboard passenger safety and comfort will be covered. (CSU)

ATC 278 C Public Relations 3 Units

Term hours: 48–54 lecture. This course introduces students to the public relations concepts and practices in the airline and travel industries. Students will examine promotional campaigns and develop their own public relations proposal with emphasis on practical applications. (CSU)

ATC 295 C Airline/Travel Internship 3 Units

Prerequisite: Completion of the Basic Airline Customer Services Certificate; or Basic Flight Attendant Certificate; or Basic Travel/Tourism Certificate.

Term hours: 16–18 lecture and 240–270 laboratory. This course offers practical work experience in an approved airline and travel related industry for the student(s) in the Airline and Travel Careers program. This course is designed to provide vocational learning opportunities through employment. (CSU)

ATC 298 C Airline/Travel Seminar**.5 to 12 Units***Prerequisite: May be required.**Corequisite: May be required.**Advisory: May be required.*

Term hours: 0–216 lecture and/or 0–1620 laboratory depending on units attempted. This course is for students who wish to increase their knowledge of the airline and travel industry. Various topics will be offered. Unit credit may range from .5 to 12 units in any given semester. Consult the class schedule to verify credit for a particular semester. May be taken for credit 1–4 times. Pass/No Pass or Pass/No Pass/Letter Grade Option or Standard Letter Grade. Fees may be required — Payable at Registration. (CSU)

ATC 299 C Independent Study**.5 to 2 Units***Prerequisite: Approved Independent Study Learning Contract.*

Term hours: 8–36 lecture. This course is designed for those students who wish to increase their knowledge of the airline and/or travel industry through professionally directed independent study or research. Unit credit may range from .5 to two units in any given semester. May be taken for credit 4 times. (CSU)

Anthropology

Division of Social Sciences

Division Dean — Nina DeMarkey*Faculty*

Becky Floyd

Craig Goralski

Counselors

Velia Lawson

Therese Mosqueda-Ponce

Daniel Pelletier

PROGRAM LEARNING OUTCOMES (PLOs)

The courses taught by this department contribute to the General Education and Basic Skills Program Learning Outcomes. Please refer to General Education and Basic Skills Program Learning Outcomes.

ASSOCIATE IN ARTS DEGREE

ANTHROPOLOGY

Program Code: 1A18368

The Associate in Arts Degree in Anthropology is designed to provide students with a comprehensive introduction to the four major fields of anthropology in order to give them the background knowledge needed by undergraduate anthropology majors for university transfer and coursework, while emphasizing the practical applications of anthropological skills and knowledge in a diversity of careers and the utility of anthropological perspectives as a life-long learning tool for interpreting world events. To earn an Associate Degree students must complete: (1) all major course requirements with a minimum grade of “C”; (2) California State University General Education Breadth requirements (CSU GE Breadth) or IGETC general education plan; (3) any elective courses to complete a minimum of 60 units; (4) complete all graduation requirements; and (5) have an overall GPA of 2.0. At least 50% of all major course work must be completed at Cypress College. Students pursuing more than one specified departmental major may double count a maximum of 7 units to fulfill major requirements. Courses that fulfill major requirements for an Associate Degree at Cypress College

might not be the same as those required for completing the major at a transfer institution offering a Baccalaureate Degree. For information on specific university requirements, please consult with your counselor, or visit the Transfer Center.

Required Courses

		Units
ANTH 101 C	Biological Anthropology	3
	or	
ANTH 101HC	Honors Biological Anthropology	(3)
ANTH 101LC	Biological Anthropology Lab	1
ANTH 102 C	Cultural Anthropology	3
	or	
ANTH 102HC	Honors Cultural Anthropology	(3)
ANTH 106 C	World Prehistory	3
	or	
ANTH 103 C	Introduction to Archaeology	3
ANTH 105 C	Language and Culture	3

Six (6) units or more from the following**Anthropology Elective Courses**

		Units
ANTH 106 C	World Prehistory	3
	or	
ANTH 103 C	Introduction to Archaeology	(3)
ANTH 104 C	Comparative Cultures	3
ANTH 107 C	Magic, Witchcraft and Religion	3
ANTH 121 C	Native North America	3
ANTH 210 C	Intro to Forensic Anthropology	3
ANTH 225 C	Cultures of Mesoamerica	3
ANTH 231 C	Field Course in Archaeology	3

Total Units Required**19**

ANTHROPOLOGY TRANSFER PROGRAM

Students should consult a counselor or www.assist.org for lower division major requirements for most California public universities. (See the Standard Definitions section of the catalog for a description of ASSIST.) Students transferring to an independent college/university should consult the catalog of the individual school and a counselor for lower division major requirements.

Anthropology (ANTH)

ANTH 101 C Biological Anthropology**3 Units***Advisory: Eligibility for ENGL 100 C.*

Term hours: 48–54 lecture. This course introduces the biological and physical aspects of what it means to be human from a scientific and evolutionary perspective. This includes an introduction to human genetics, principles of natural selection and other forces of evolution, physical and behavioral characteristics of non-human primates, fossil evidence of primate and human evolutionary change, and information about modern human variation. Duplicate credit not granted for ANTH 101HC or ANTH 201 C. (UC Credit Limitation/CSU, AA GE, CSU GE, IGETC)

ANTH 101HC Honors Biological Anthropology**3 Units***Advisory: Eligibility for ENGL 100 C.*

Term hours: 48–54 lecture. This course is an enhanced introduction to the biological and physical aspects of what it means to be human from a scientific and evolutionary perspective. This includes an introduction to human genetics, principles of natural selection and other forces of evolution, physical and behavioral characteristics of non-human primates, fossil evidence of primate and human evolutionary change, and information about modern human variation. Duplicate Credit not granted for ANTH 101 C. (UC Credit Limitation/CSU, AA GE, CSU GE, IGETC)

ANTH 101LC Biological Anthropology Lab 1 Unit

Prerequisite: Completion of or concurrent enrollment in ANTH 101 C or ANTH 101HC.

Term hours: 48–54 lecture. This course provides an introduction to experimental and experimental laboratory research methods used in biological anthropology. Topics will include the scientific method, Mendelian and population genetics, the forces of evolution, anthropometry and other measures of human variation, human osteology, taxonomy, biology and behavior of living and extinct primates, and the evidence for human evolution including fossil hominids. One field trip to a regional zoo will be required for non-human primate observations. Zoo admissions range \$6.00–\$35.00. (UC/CSU, AA GE, CSU GE, IGETC)

ANTH 102 C Cultural Anthropology 3 Units

Advisory: Eligibility for ENGL 100 C.

Term hours: 48–54 lecture. This introductory course explores the nature of culture and how culture guides human behavior. Topics include language, subsistence, economics, social and political organization, marriage, kinship, religion, the arts, and culture change. This course is intended for students who are interested in gaining a deeper understanding of themselves and their fellow human beings. Duplicate credit not granted for ANTH 102HC. (UC Credit Limitation/CSU, AA GE, CSU GE, IGETC)

ANTH 102HC Honors Cultural Anthropology 3 Units

Advisory: Eligibility for ENGL 100 C.

Term hours: 48–54 lecture. This enhanced introductory course explores the nature of culture and how culture guides human behavior. Topics include language, subsistence, economics, social and political organization, marriage, kinship, religion, the arts, and culture change. This course is intended for students who are interested in gaining a deeper understanding of themselves and their fellow human beings. Duplicate credit not granted for ANTH 102 C. (UC Credit Limitation/CSU, AA GE, CSU GE, IGETC)

ANTH 103 C Introduction to Archaeology 3 Units

Formerly ANTH 203 C.

Advisory: Eligibility for ENGL 100 C.

Term hours: 48–54 lecture. This course is an introduction to the basic principles, theories, methods and practice of archaeology: how archaeological sites are discovered, surveyed, tested, excavated, dated, recorded, preserved, analyzed, interpreted, and published. It includes discussions on site and cultural development, how sites are preserved, taphonomy of the archaeological record, geoarchaeology, bioarchaeology, technology and cultural adaptation to the environment. Furthermore, the course elucidates the difference between academic and contract archaeology, how to join archaeological expeditions, and how they are funded. (UC/CSU, AA GE, CSU GE, IGETC)

ANTH 104 C Comparative Cultures 3 Units

Advisory: Eligibility for ENGL 100 C.

Term hours: 48–54 lecture. This course uses a focused cross-cultural and comparative approach to introduce anthropological concepts such as modes of production, family and kinship, economics, political organization, art and religion. Globalization and culture change will also be explored. A representative selection of culture areas will be featured through ethnography, providing perspective on the variety of human adaptation and how cultural systems are integrated. (UC/CSU, CSU GE, IGETC)

ANTH 105 C Language and Culture 3 Units

Advisory: Eligibility for ENGL 100 C.

Term hours: 48–54 lecture. This course explores the nature of language in relation to culture and how language processes develop and change. Students will examine how cultural knowledge is linguistically organized and how language shapes our perception of the world, and how it acts as a guide, both symbolic and practical, to understanding human actions. A basic introduction into the primary concepts of the discipline help students to understand what language reveals about human beings as bearers of culture. (UC/CSU, CSU GE, IGETC)

ANTH 106 C World Prehistory 3 Units

Advisory: Eligibility for ENGL 100 C.

Term hours 48–54 lecture. This course is an introduction to the prehistoric development of civilizations both in the Old World and the New World beginning with early modern humans. Because the prehistoric is the time prior to cultures' writing about themselves, students will examine archaeological methods and theories used to describe the past. Topics will include the spread of modern humans, Mesolithic societies, the origins of food production and the evolution and collapse of various world civilizations. (UC/CSU, AA GE, CSU GE, IGETC)

ANTH 107 C Magic, Witchcraft and Religion 3 Units

Advisory: Eligibility for ENGL 100 C.

Term hours: 48–54 lecture. This course is an anthropological survey of systems of magic, witchcraft, and religion from the past and the present, from societies around the world. Examines beliefs and practices in cultural settings with respect to the role of the supernatural. Special topics include myth, religious healing, witchcraft and sorcery, ritual and millenarian movements. (UC/CSU, CSU GE, IGETC)

ANTH 121 C Native North America 3 Units

Advisory: Eligibility for ENGL 100 C.

Term hours: 48–54 lecture. This course is an anthropological survey of the cultures of Native American societies of North America. Topics include the peopling of the New World, traditional culture, the impacts of culture contact both from Western cultures and native peoples' cultures on one another, and contemporary issues. (UC/CSU, CSU GE, IGETC, CUL DIV)

ANTH 210 C Introduction to Forensic Anthropology 3 Units

Advisory: Completion of ENGL 060 C.

Term hours: 48–54 lecture. Forensic anthropology is the application of standard, scientific, anthropological methods and techniques to identify human remains and to assist in the detection of a crime or after a mass disaster. This course provides a basic overview of the field of forensic anthropology, human osteology, the techniques used to make estimations of age, sex, ancestry and stature, recovery techniques and the analytic techniques and procedures used in the medico-legal framework. This class includes extensive analysis of anthropological methods, ethics, socio-cultural considerations and civic responsibilities inherent to forensic anthropology. (UC/CSU)

ANTH 225 C Cultures of Mesoamerica 3 Units

Advisory: Eligibility for ENGL 100 C.

Term hours: 48–54 lecture. This course explores the diverse cultures of ancient Mesoamerica from the origins of civilization through the initial period of Spanish contact. Mesoamerica is defined as the culture area extending from the Rio Grande to the north to the Isthmus of Panama to the south. While the contributions of all four fields of anthropology will be explored, this course will primarily approach the cultures of Mesoamerica from archaeological and ethnohistoric perspectives. The subsistence practices, social organization and ideologies of past cultures will be presented and links between these ancient lifeways and aspects of the modern cultures of northern Latin America will be discussed. (UC/CSU, CSU GE, IGETC)

ANTH 231 C Field Course in Archaeology 3 Units*Advisory: ANTH 103 C.*

Term hours: 16–18 lecture and 96–108 laboratory. This course provides practical experience in field archaeology through a combination of lectures and laboratory hours in a fieldwork setting. It is designed to provide a basic understanding of site survey, archaeological methods, laboratory analysis, local prehistory and museum preparation. May be taken for credit 2 times. (CSU)

ANTH 298 C Anthropology Seminar .5 to 12 Units*Prerequisite: May be required.**Corequisite: May be required.**Advisory: May be required.*

Zero to twelve hours lecture and zero to thirty-six hours laboratory per week. This is a lecture/discussion type course developed on a particular limited problem or topic of interest to students. It is designed for able students who wish to increase their knowledge on a particular topic concerning which no other regular class is offered. A paper or group activity may be requested. Credit may range from .5 to 12 units. Consult the class schedule for the offerings in a particular semester. May be taken for credit 1–4 times. Pass/No Pass or Pass/No Pass/Letter Grade Option or Standard Letter Grade. Fees may be required — Payable at Registration. (UC Credit Limitation/CSU)

ANTH 299 C Anthropology Independent Study 1 Unit*Prerequisite: Approved Independent Study Learning Contract.*

May be taken for credit 3 times.

Varying hours of scheduled conferences per week. Independent study is for able students who wish to extend their knowledge of a particular area through individual research and study. It is though that topics might develop out of a curiosity stimulated in a regular class. The student would then contact the supervising instructor to develop a contract for his/her particular interest so that they could learn more regarding their special topic. (UC Credit Limitation/CSU)

Art

Division of Fine Arts

Division Dean — Ting-Pi (Joyce) Carrigan*Faculty*

Edward Giardina

Ian Holmes

Sarah Jaffray

Michael Johnson

Paul Paiement

Joyce Patti

Molly Schulps

Counselors

Renay Laguana-Ferinac

Renee Ssensalo

PROGRAM LEARNING OUTCOMES (PLOs)

Art Department

- Given art materials, students will be able to show their knowledge of various art processes, theory, and technical skills.
- Given art materials, students will be able to effectively communicate content through the principles and elements of design.

- Given art works and materials, students will be able to critically analyze the principles and elements of design for content and historical importance.
- Students will develop artistic skills to visually articulate and comprehend the interconnection between art and culture.

ASSOCIATE IN ARTS DEGREE

ADVERTISING DESIGN Program Code: 1A10448

The primary emphasis is to prepare the student for employment. To earn an Associate Degree students must complete: (1) all major course requirements with a minimum grade of "C"; (2) 25 units of General Education Graduation Requirements; (3) the cultural diversity and reading requirements; (4) any elective courses to complete a minimum of 60 units; and, (5) have a minimum GPA of 2.0. At least 50% of all major course work must be completed at Cypress College.

Courses that fulfill major requirements for an Associate Degree at Cypress College might not be the same as those required for completing the major at a transfer institution offering a Baccalaureate Degree. For information on specific university requirements, please consult with your counselor, or visit the Transfer Center.

Required courses are listed in suggested sequence:

Course #	Title	Units
*ART 182 C	Freehand Drawing	3
***ART 110 C	Introduction to Art	3
ART 120 C	Two-Dimensional Design	3
MAD 101 C	Intro to Computer Graphics/Win	3
ART 185 C	Life Drawing	3
ART 140 C	Advertising/Graphic Design 1	3
MAD 140 C	DeskTop Publishing 1/Mac	3
ART 141 C	Advertising/Graphic Design 2	3
ART 142 C	Advertising/Graphic Design 3	3
MAD 112 C	Electronic Illustration/Mac	3
	or	
MAD 113 C	Electronic Illustration/Win	(3)
ART 244 C	Illustration	3
Select a minimum of 8 units from the elective courses listed below		8
Total Units Required		41

Electives

**ART 111 C, 112 C, 112HC	Survey of Art History I and II	3, 3
*ART 182 C	Freehand Drawing	3
ART 185 C	Life Drawing	3
ART 130 C	Printmaking	3
PHOT 101 C	Introduction to Photography	3
MKT 103 C	Principles of Advertising	3
MAD 147 C	Desktop Publishing 3/Win	3

*A score of 3 or higher on the Advanced Placement (AP) Art (Studio Drawing) exam with portfolio approval, meets this requirement upon petition through Admissions and Records. See a counselor for more information.

**A score of 3 or higher on the Advanced Placement (AP) Art (History) exam meets this requirement upon petition through Admissions and Records. See a counselor for more information.

***ART 100 C may be substituted for ART 110 C as a required course.

ASSOCIATE IN ARTS DEGREE

ART

Program Code: 1A03776

This program is designed to prepare the student in the development of conceptual and technical skills required by artists in certain occupations.

To earn an Associate Degree students must complete: (1) all major course requirements with a minimum grade of "C"; (2) 25 units of General Education Graduation Requirements; (3) the cultural diversity and reading requirements; (4) any elective courses to complete a minimum of 60 units; and, (5) have a minimum GPA of 2.0. At least 50% of all major course work must be completed at Cypress College.

Courses that fulfill major requirements for an Associate Degree at Cypress College might not be the same as those required for completing the major at a transfer institution offering a Baccalaureate Degree. For information on specific university requirements, please consult with your counselor, or visit the Transfer Center.

Required Courses are listed in suggested sequence:

Course #	Title	Units
*ART 182 C	Freehand Drawing	3
ART 120 C	Two-Dimensional Design	3
ART 122 C	Gallery/Portfolio Design	3
**ART 111 C	Survey of Art History I	3
**ART 112 C	Survey of Art History II	3
	or	
**ART 112HC	Honors Survey of Art History II	(3)
ART 121 C	Three-Dimensional Design	3
Select at least 6 units from the following:		6
ART 185 C	Life Drawing	(3)
*ART 182 C	Freehand Drawing (additional semester)	(3)
ART 189 C	Fundamentals of Painting	(3)
Select a minimum of 11 units from the Art course offerings not listed above.		11
Total Units Required		35

*A score of 3 or higher on the Advanced Placement (AP) Art (Studio Drawing) exam with portfolio approval, meets this requirement upon petition through Admissions and Records. See a counselor for more information.

**A score of 3 or higher on the Advanced Placement (AP) Art (History) exam meets this requirement upon petition through Admissions and Records. See a counselor for more information.

ART TRANSFER PROGRAM

Students should consult a counselor or www.assist.org for lower division major requirements for most California public universities. (See the Standard Definitions section of the catalog for a description of ASSIST.) Students transferring to an independent college/university should consult the catalog of the individual school and a counselor for lower division major requirements.

Art (ART)

ART 100 C Fundamentals of Art

3 Units

Term hours: 48–54 lecture. This introductory course investigates the visual elements and principles of art through lectures, reading, films and hands-on experience. It also examines, in the same manner, historical styles and themes in art as well as materials and techniques. Pass/No Pass/Letter Grade Option. Cost of museum visit and materials will not exceed \$20.00. (UC/CSU, AA GE, CSU GE, IGETC)

ART 110 C Introduction to Art

3 Units

Advisory: Completion of ENGL 100 C.

Term hours: 48–54 lecture. This course is designed to expose the student to art from prehistoric times to the present: its purposes, materials, themes, history, and significance. It also acquaints the student with art and artists' roles in present and past societies, and helps the student understand the uses of materials and visual elements (i.e., line, color, etc.) to communicate ideas in architecture, sculpture, painting, ceramics, crafts, filmmaking, printmaking, etc. Major writing assignments are required. Pass/No Pass/Letter Grade Option. Cost of museum visit will not exceed \$15.00. (UC/CSU, AA GE, CSU GE, IGETC)

ART 111 C Survey of Art History I

3 Units

Advisory: Completion of ENGL 100 C.

Term hours: 48–54 lecture. This course studies the development of ancient and medieval architecture, sculpture and painting in the Western and Eastern cultures. Emphasis is placed on examining how art records and shapes history, how style communicates the ideas of the artist and his culture, and how symbols, techniques, materials and subjects are used and transferred from one culture to another. Major writing assignments are required. Pass/No Pass/Letter Grade Option. Cost of museum visit will not exceed \$15.00. (UC/CSU, AA GE, CSU GE, IGETC)

ART 112 C Survey of Art History II

3 Units

Advisory: Completion of ENGL 100 C.

Term hours: 48–54 lecture. This course studies the development of architecture, sculpture and painting in the Western world from the Renaissance through the twenty-first century. Emphasis is placed on examining how art records and shapes history, how style communicates the ideas of the artist and his culture, and how symbols, techniques, materials and subjects are used and transferred from one culture to another. Major writing assignments are required. Cost of museum visit will not exceed \$15.00. Duplicate credit not granted for ART 112HC. Pass/No Pass/Letter Grade Option. (UC Credit Limitation/CSU, AA GE, CSU GE, IGETC)

ART 112HC Honors Survey of Art History II

3 Units

Advisory: Completion of ENGL 100 C.

Term hours: 48–54 lecture. This is an enhanced course that studies the development of architecture, sculpture, and painting of the Western world from the Renaissance through the twenty-first century. Emphasis is placed on examining how art records and shapes history, how style communicates the ideas of the artist and his culture, and how symbols, techniques, materials, and subjects are used and transferred from one culture to another. Cost of museum visit will not exceed \$15.00. Duplicate credit not granted for ART 112 C. (UC Credit Limitation/CSU, AA GE, CSU GE, IGETC)

ART 114 C Modern Art History

3 Units

Advisory: Completion of ENGL 100 C.

Term hours: 48–54 lecture. This course deals with the nature of twentieth and twenty-first century art and its origins in the late nineteenth century. Emphasis is placed on examining how art reflects history, how style communicates the ideas of the artist and his/her culture and how symbols, techniques, materials and subjects are used and expanded in 20th and 21st century artistic expression. Major written assignments are required. Cost of museum visit will not exceed \$15.00. Pass/No Pass/Letter Grade Option. (UC/CSU, AA GE, CSU GE, IGETC)

ART 120 C Two-Dimensional Design

3 Units

Term hours: 32–36 lecture and 64–72 laboratory. This course provides the foundation for all visual arts, by examining the concepts, terminology, techniques and materials used in two-dimensional design. Materials fees are used for materials provided by the Art Department. \$25.00 Payable at Registration. (UC/CSU, AA GE, CSU GE)

ART 121 C Three-Dimensional Design 3 Units

Term hours: 32–36 lecture and 64–72 laboratory. This course is an introductory course covering the materials, techniques, and tools used to create three-dimensional forms. This course emphasizes the vocabulary of three-dimensional design and its application to problem solving in three-dimensions. \$20.00 fee for materials used in common — Payable at Registration. (UC/CSU)

ART 122 C Gallery/Portfolio Design 3 Units

Term hours: 32–36 lecture and 64–72 laboratory. This course provides practical experience in gallery operation, art exhibit installation, and artist portfolio preparation. Students will have an opportunity to collaborate in the planning, designing, and installing of art exhibitions in the college gallery and to visit and evaluate exhibitions in other local galleries and museums. Students will also create individual art installations and professional artist portfolios. May be taken for credit 4 times. Material Fees not to exceed \$20.00. (CSU)

ART 130 C Printmaking 3 Units

Term hours: 32–36 lecture and 64–72 laboratory. This course will introduce the artist to concepts and techniques of drawing, design, and color through the use of fine art printing medias such as etching, lithography, and woodcut. Assignments in this course are flexible based upon personal interest. May be taken for credit 4 times. \$10.00 Material Fee — Payable at Registration. (UC/CSU)

ART 140 C Advertising/Graphic Design I 3 Units

Corequisite: Completion of or concurrent enrollment in ART 120 C.
Term hours: 32–36 lecture and 64–72 laboratory. This is a basic course in advertising/graphic design, with emphasis on problem solving in lettering, typography, and trademark design. It includes development of concept development, layout, and presentation skills. Projects include lettering design, layout, trademark design, and typography. Students are introduced to non-electronic and electronic design techniques. \$25.00 fee for materials provided by the department — Payable at Registration. (CSU)

ART 141 C Advertising/Graphic Design 2 3 Units

Prerequisite: ART 140 C.
Term hours: 32–36 lecture and 64–72 laboratory. This is an intermediate course in advertising/graphic design with emphasis upon development of a highly comprehensive finished portfolio. Course includes refinement of concept development, layout, and presentation skills. Students refine their non-electronic and electronic design techniques. \$25.00 fee for materials provided by the department — Payable at Registration. (CSU)

ART 142 C Advertising/Graphic Design 3 3 Units

Corequisite: ART 141 C.
Term hours: 32–36 lecture and 64–72 laboratory. This is an advanced course in advertising/graphic design with an emphasis upon development of comprehensive finished portfolio pieces. This course includes group and individual design projects planned to provide experience in all steps of graphic design from concepts and development of a campaign continuity to production specifications. Special attention and emphasis is placed on planning and preparation of an advertising/graphic portfolio. \$25.00 fee for materials provided by the department — Payable at Registration. (CSU)

ART 144 C Cartooning 3 Units

Term hours: 32–36 lecture and 64–72 laboratory. This course is an introduction to basic cartooning techniques which includes sketching, inking, and the development of characters. Projects include gag-line cartooning, political cartooning, and the development of a weekly cartoon strip. In addition, there will be an analysis of the elements of both the humorous and the dramatic in cartoon art. This analysis will include a review of historically significant Sunday funnies and comic book characters, an examination of major trends in comic art from 1895 to the present and fundamentals of storyboard development. May be taken for credit 3 times. (CSU)

ART 150 C Ceramics Handbuilding 3 Units

Term hours 32–36 lecture and 64–72 laboratory. Basic information about ceramics will be covered. Learning to construct with off wheel (hand-building) techniques will be applied to convey ideas, images, and feelings. Visual vocabulary as it pertains to all of the arts will be stressed. Basic technology of clay, glazes, and firing procedures is included. \$20.00 Material Fee — Payable at Registration. (UC/CSU, AA GE, CSU GE)

ART 151 C Ceramics Throwing 3 Units

Term hours: 32–36 lecture and 64–72 laboratory. Basic information about ceramics will be covered. With an emphasis on learning to use the potter's wheel as a tool, students will use it to convey ideas, images, and feelings. Visual vocabulary as it pertains to all of the arts is emphasized. Basic technology of clay, glazes, and firing procedures are included. \$20.00 Material Fee — Payable at Registration. (UC/CSU, AA GE, CSU GE)

ART 152 C Technical/Conceptual Ceramics 3 Units

Prerequisite: ART 150 C or ART 151 C with minimum grades of "C."
Term hours: 32–36 lecture and 64–72 laboratory. This course deals with advanced technical skills in ceramic construction and visual concepts. Identification and application of one's personal aesthetic will be emphasized. Clay, glazes, and firing techniques are integral to this course. \$20.00 Material Fee — Payable at Registration. (UC/CSU)

ART 153 C Ceramic Studio Exploration 3 Units

Prerequisite: ART 152 with a minimum grade of "C."
Term hours: 32–36 lecture and 64–72 laboratory. Advanced technical and conceptual skills will be covered. Synthesizing the individual development of a personal aesthetic will be used. Application of this aesthetic will be used to create ceramic objects. Further technology of clay, glazes, and firing possibilities is expected. May be taken for credit 4 times. \$20.00 Material Fee — Payable at Registration. (UC/CSU)

ART 154 C Ceramic Aesthetics and Finishes 3 Units

Prerequisite: ART 153 C with a minimum grade of "C."
Term hours: 32–36 lecture and 64–72 laboratory. This class which explores various firing processes, glaze exploration and philosophy is designed for the advanced ceramic student. Developing a personal aesthetic towards raku will be emphasized. Experimentation of glazes will be stressed. May be taken for credit 4 times. \$20.00 Material Fee — Payable at Registration. (UC/CSU)

ART 155 C Art Open Laboratory .5 to 2 Units

Corequisite: Concurrent enrollment in ART 120 C, ART 130 C, ART 150–154 C, ART 182 C, ART 185 C or ART 244 C.
Term hours: 24–108 laboratory depending on units attempted. This course is designed as an open laboratory. Working time can be anytime the laboratory is open on an individual basis. This open lab with flexible hours and variable units is designed to provide students with space and equipment needed to complete art assignments; therefore, concurrent enrollment in any of the following classes ART 120 C, ART 130 C, ART 150–154 C, ART 182 C, ART 185 C or ART 244 C is required. Twenty-seven (27) hours are required for each .5 units up to 108 hours for two (2) units. Each subsequent credit represents advancing levels of achievement. Levels must be taken in sequence. May be taken for credit 4 times. Pass/No Pass only. (CSU)

ART 174 C Jewelry Design 2 Units

Term hours: 16–18 lecture and 48–54 laboratory. This is a course covering the design and construction of jewelry and small fabricated metal pieces. Emphasis will be placed on fabrication and direct casting techniques and their potential. May be taken for credit 4 times. \$20.00 fee for materials used in common— Payable at Registration. (CSU)

ART 175 C Metalsmithing**2 Units***Prerequisite: ART 174 C.*

Term hours: 16–18 lecture and 48–54 laboratory. The emphasis of this course will be placed on the development of advanced design skills, lost wax casting and stone setting techniques. May be taken for credit 4 times. \$20.00 fee for materials used in common— Payable at Registration. (CSU)

ART 182 C Freehand Drawing**3 Units**

Term hours: 32–36 lecture and 64–72 laboratory. This course is an introductory class in the fundamentals of drawing. The student will be exploring traditional and experimental methods in drawing. There is strong emphasis on foundation skills such as form, value, composition and perspective. Perceptual skills and self expression will also be stressed. The student will work from nature, man made objects and his or her own imagination. Non objective and abstract considerations will be examined in representational and experimental drawing. A variety of media will be introduced, such as graphite, charcoal, conte, pen and ink. Advanced students will be exposed to more color and mixed media. May be taken for credit 4 times. (UC/CSU, AA GE, CSU GE)

ART 185 C Life Drawing**3 Units**

Term hours: 32–36 lecture and 64–72 laboratory. Life Drawing is an introduction to the representational and expressive drawing of the human figure. It is a foundation for figure painting. The course provides an opportunity for exploration of various methods, approaches, and media in figure drawing. May be taken for credit 4 times. (UC/CSU, AA GE)

ART 189 C Fundamentals of Painting**3 Units**

Term hours: 32–36 lecture and 64–72 laboratory. The purpose of this course is to approach painting as a creative and problem solving process. Emphasis will be placed on the acquisition of technical/formal skills and the development of a personal artistic vision. This course will include a variety of media and the fundamentals of composition, color theory, and craftsmanship as applied to painting and the fine arts. May be taken for credit 4 times. (UC/CSU, AA GE, CSU GE)

ART 191 C Life Painting**3 Units***Prerequisite: ART 185 C or ART 189 C.*

Term hours: 32–36 lecture and 64–72 laboratory. Life Painting is an introduction to painting the human figure as a means to a more penetrating perception of visual phenomena and as a means of creative expression. Paintings will progress from a limited palette to full color with the emphasis on light, color, composition and form. The course provides an opportunity for examination of historical and contemporary examples of figure painting and for exploration of various methods, approaches and media. This course satisfies the requirements for units in lower division Life Painting for transfer. May be taken for credit 4 times. (UC/CSU)

ART 216 C Latin American Art**3 Units***Advisory: ENGL 100 C.*

Term hours: 48–54 lecture. This course is a survey of arts and architecture of Mexico, Central America, and South America from 1200 BC to the late 20th century. Pass/No Pass/Letter Grade Option. Cost of museum visit will not exceed \$15.00. (UC/CSU, CSU GE, IGETC)

ART 244 C Illustration**3 Units***Prerequisite: Completion of or concurrent enrollment in ART 182 C.*

Term hours: 32–36 lecture and 64–72 laboratory. This is an introductory to intermediate course in the art of illustration. Primary emphasis is on the design and execution of illustrations for various uses in a variety of media. Course content includes designing to communicate a message, composition, style, development of preliminary drawings, preparation of drawings for printed reproduction, and experiments in the use of various media. May be taken for credit 4 times. \$20 Material Fee — Payable at Registration. (CSU)

ART 298 C Art Seminar**.5 to 12 Units***Prerequisite: May be required.**Corequisite: May be required.**Advisory: May be required.*

Term hours: 0–216 lecture and/or 0–864 laboratory depending on units attempted. Various classes may be offered which are designed to meet the interests and needs of the student and faculty. May be taken for credit 1–4 times. Pass/No Pass or Pass/No Pass/Letter Grade Option or Standard Letter Grade. Fees may be required — Payable at Registration or Bookstore. (UC Credit Limitation/CSU)

ART 299 C Independent Study**.5 to 2 Units***Prerequisite: Approved Independent Study Learning Contract.*

Term hours: 18–72 conference/contract. This is a course that is designed for the student to pursue an increased knowledge of a particular art discipline. Unit credit may range from .5 to 2 units in any given semester; units earned will be based on 18 hours for each .5 units. May be taken for credit 4 times. (UC Credit Limitation) (CSU)

Asian Studies

TRANSFER PROGRAM

Students should consult a counselor or www.assist.org for lower division major requirements for most California public universities. (See the Standard Definitions section of the catalog for a description of ASSIST.) Students transferring to an independent college/university should consult the catalog of the individual school and a counselor for lower division major requirements.

Astronomy

Division of Science/Engineering/Mathematics

Division Dean — Richard Fee*Faculty*

Ron Armale
Michael Frey

Counselor

Deidre Porter

PROGRAM LEARNING OUTCOMES (PLOs)

The courses taught by this department contribute to the General Education and Basic Skills Program Learning Outcomes. Please refer to General Education and Basic Skills Program Learning Outcomes.

Astronomy (ASTR)

ASTR 116 C Introduction to Astronomy 3 Units

Term hours 48–54 lecture. This course is an introduction to the ideas, concepts, and theories of astronomy. Topics include the night sky, history of astronomy, the solar system, extra solar planets, stars, the interstellar medium, galaxies, cosmology, and extraterrestrial life in the universe. On-campus observation sessions may be held. Duplicate credit not granted for ASTR 116HC. Pass/No Pass/Letter Grade Option. (UC Credit Limitation/CSU, AA GE, CSU GE, IGETC)

ASTR 116HC Honors Introduction to Astronomy 3 Units

Term hours: 48–54 lecture. This course is an enhanced introduction to the concepts and theories of astronomy. Topics include the night sky, history of astronomy, the solar system, the sun, moon, planets, extra solar planets, stars, the interstellar medium, black holes, galaxies, cosmology, and life in the universe. Telescope observation sessions will be held on campus. Duplicate credit not granted for ASTR 116 C. (UC Credit Limitation/CSU, AA GE, CSU GE, IGETC)

ASTR 117 C Astronomy Lab 1 Unit

Prerequisite: Completion of or concurrent enrollment in ASTR 116 C or ASTR 116HC.

Term hours: 48–54 laboratory. This course comprises an introduction to techniques of Astronomical measurement and analysis of Astronomical data. Emphasis will be on understanding how scientific knowledge is constructed, i.e. answering the question: how do we know what we know about the universe? Students will perform hands-on measurements, observations and exercises in data analysis relating to the solar system, stars, galaxies, large-scale structure of the universe, and cosmology. On campus telescopic observing may be done by students in the Astronomy Laboratory. Duplicate credit not granted for ASTR 117HC. (UC Credit Limitation/CSU, AA GE, CSU GE, IGETC)

ASTR 117HC Honors Astronomy Lab 1 Unit

Prerequisite: Completion of or concurrent enrollment in ASTR 116 C or ASTR 116HC.

Term hours: 48–54 laboratory. This enhanced course comprises an introduction to Astronomical measurement and analysis of Astronomical data. Emphasis will be on how scientific knowledge is constructed, i.e. answering the question: how do we know what we know about the universe? Students will perform hands-on measurements, observations and exercises in data analysis relating to the solar system, stars, galaxies, large-scale structure of the universe, and cosmology. Students will learn how to use a telescope, which may be computer controlled and take digital images. Duplicate credit not granted for ASTR 117 C. (UC Credit Limitation/CSU, AA GE, CSU GE, IGETC)

Automotive Collision Repair

Division of Career Technical Education

Division Dean — Steve Donley

Faculty

Daniel Snook

Larry Ramos

Counselor

Jane Jepson

PROGRAM LEARNING OUTCOMES (PLOs)

Auto Collision Repair

Upon completion of the Automotive Collision Repair courses students will be able to develop the following skills required by the National Automotive Technology Education Foundation (NATEF) to enhance their employment opportunities and advance their career goals:

- Measure and diagnose structural damage using tram gauges and electronic measuring systems.
- Determine the extent and direction of damage; plan and document the methods and sequence of repairs.
- Remove and replace damaged sections of steel and aluminum body structures.
- Clean and prepare metal to be welded, assure good metal fit-up, clamp and tack weld as required.
- Perform the following welds: continuous, plug, butt weld with and without backing and fillet etc.
- Inspect, remove, store and replace body panels and components that may interfere with or be damaged during repair.
- Straighten contours of damaged panels to a suitable condition for body filling or metal finishing using power tools, hand tools and weld-on pulling attachments.
- Restore corrosion protection throughout all repair areas.
- Demonstrate hammer and dolly techniques including hot and cold shrinking of panel areas to proper contour.
- Mix and apply body filler and sand to correct contour.
- Inspect, adjust, repair or replace window regulators, run channels, glass, power mechanisms, and related controls.
- Perform visual and destructive tests on each type of weld.
- Identify types of plastics; rigid, semi-rigid or flexible and determine reparability.
- Clean, inspect and repair reusable fasteners and identify one-time use fastener.

ASSOCIATE IN SCIENCE DEGREE

AUTOMOTIVE COLLISION

REPAIR

Program Code: 1S07832

The following program is designed to prepare students for employment as automotive collision technicians and in numerous other related areas of the automotive and transportation industry. Training is given in both theory and practical skills. Directed practical work is given in all areas of automotive collision repair under simulated on-the-job conditions. The program suggested will provide the student the opportunity to acquire the knowledge and skills demanded of the modern automotive collision technician.

To earn an Associate Degree students must complete: (1) all major course requirements with a minimum grade of “C”; (2) 25 units of General Education Graduation Requirements; (3) the cultural diversity and reading requirements; (4) any elective courses to complete a minimum of 60 units; and, (5) have a minimum GPA of 2.0. At least 50% of all major course work must be completed at Cypress College.

Courses that fulfill major requirements for an Associate Degree at Cypress College might not be the same as those required for completing the major at a transfer institution offering a Baccalaureate Degree. For information on specific university requirements, please consult with your counselor, or visit the Transfer Center.

Required Courses are listed in suggested sequence:

Course #	Title	Units
ACR 001 C	Automotive Collision Repair Tech I	6
ACR 002 C	Automotive Collision Repair Tech II	6
ACR 003 C	Automotive Collision Repair Tech III	6
ACR 004 C	Automotive Collision Repair Tech IV	6
ACR 011 C	Collision Refinishing Tech I	4, 4
ACR 012 C	Collision Damage Appraisal	3
ACR 030 C	Electrical Systems and Component Repair	4
ACR 040 C	Structural Alignment Repair	4
Total Units Required		43

Electives

ACR 013 C	Computerized Automotive Damage Appraisal	3
ACR 020 C	Auto Detailing and Car Care	2.5
ACR 050 C	Automotive Collision Special Projects	2–3
ACR 060 C	Collision Repair Management	3
ACR 070 C	Automotive Color Matching	3

AUTOMOTIVE COLLISION REPAIR CERTIFICATE Program Code: 1C21110

Primary emphasis is to prepare the student for occupational competency. To earn a certificate, students must complete the required courses as listed with a minimum grade of “C.” At least 50% of all course work must be completed at Cypress College.

Required courses are listed in suggested sequence:

Course #	Title	Units
ACR 001 C	Automotive Collision Repair Tech I	6
ACR 002 C	Automotive Collision Repair Tech II	6
ACR 003 C	Automotive Collision Repair Tech III	6
ACR 004 C	Automotive Collision Repair Tech IV	6
ACR 011 C	Collision Refinishing Tech I	4, 4
ACR 012 C	Collision Damage Appraisal	3
ACR 030 C	Electrical Systems and Component Repair	4
ACR 040 C	Structural Alignment Repair	4
ENGL 095 C	Effective Writing	3
Select a minimum of 3 units from the elective courses listed below		3
Total Units Required		49

Electives

ACR 013 C	Computerized Automotive Damage Appraisal	3
ACR 020AC	Auto Detailing and Car Care	2.5
ACR 050 C	Automotive Collision Special Projects	2–3
ACR 060 C	Collision Repair Management	3
ACR 070 C	Automotive Color Matching	3
AT 101 C	Survey of the Automobile	3
AT 160 C	Basic Auto Electricity	4
MATH 010 C	Basic Mathematics	4
MGT 261 C	Small Business Management	3
MKT 208 C	Principles of Selling	3
COMM 050 C	Effective Oral Communication	3

AUTOMOTIVE DAMAGE APPRAISAL CERTIFICATE Program Code: 1K12970

The following program is designed to prepare students for employment as automotive damage appraisers. Training is given in both theory and practical application. Directed practical work is given in all areas of automotive damage appraisal.

To earn a certificate, students must complete the required courses as listed with a minimum grade of “C.” At least 50% of all course work must be completed at Cypress College.

Required courses are listed in numeric sequence:

Course#	Title	Units
ACR 001 C	Automotive Collision Repair Tech I	6
ACR 011 C	Collision Refinishing Tech I	4
ACR 012 C	Collision Damage Appraisal	3
ACR 013 C	Computerized Automotive Damage Appraisal	3
Total Units Required		16

AUTOMOTIVE PAINT AND REFINISHING CERTIFICATE Program Code: 1C07833

This program is designed to prepare students with the skills necessary to enter the Auto Paint and Refinishing industry. Training is given in both theory and practical skills. Directed practical work is given under simulated on-the-job conditions.

To earn a certificate, students must complete the required courses as listed with a minimum grade of “C.” At least 50% of all course work must be completed at Cypress College.

Required courses are listed in suggested sequence:

Course#	Title	Units
ACR 001 C	Automotive Collision Repair Tech I	6
ACR 011 C	Collision Refinishing Tech I	4, 4, 4
ACR 012 C	Collision Damage Appraisal	3
ACR 020AC	Auto Detailing and Car Care	2.5
ACR 070 C	Automotive Color Matching	3
ENGL 095 C	Effective Writing	3
Select a minimum of 6 units from the elective course list		6
Total Units Required		35.5

Electives

ACR 020 C	Advanced Auto Detailing	2.5
ACR 050 C	Automotive Collision Special Projects	2–3
ACR 060 C	Collision Repair Management	3
AT 101 C	Survey of the Automobile	3
MKT 208 C	Principles of Selling	3

AUTOMOTIVE SALES AND SERVICE CERTIFICATE Program Code: 1K15688

This program is designed to prepare students for customer service and sales positions in the automotive industry. It provides students with a basic knowledge of automobile operations, general maintenance requirements, and damage appraisal procedures along with marketing and management principles. The certificate will enable students to work in a variety of non technical areas in an automobile dealership, repair shop, or insurance company as a service representative, salesperson, or estimator.

To earn a certificate, students must complete the required courses as listed with a minimum grade of “C.” At least 50% of all course work must be completed at Cypress College.

Required courses are listed in suggested sequence:

Course#	Title	Units
AT 101 C	Survey of the Automobile or	3
AT 110 C	Automotive Fundamentals	(4)
ACR 012 C	Collision Damage Appraisal	3
MKT 222 C	Principles of Marketing	3
MKT 208 C	Principles of Selling	3
MGT 266 C	Human Relations in Business	3
Total Units Required		15–16

INSURANCE CO/AUTO COLLISION REPAIR INDUSTRY MANAGEMENT SKILLS CERTIFICATE

Program Code: 1K12982

This program is designed to prepare students for employment as insurance company appraisers and managers of automotive collision repair facilities. It is also designed to give the students knowledge in the auto collision repair process and to develop management skills necessary for success in their chosen profession.

To earn a certificate, students must complete the required courses as listed with a minimum grade of "C." At least 50% of all course work must be completed at Cypress College.

Required courses are listed in numeric sequence:

Course#	Title	Units
ACR 011 C	Collision Refinishing Tech I	4
ACR 060 C	Collision Repair Management	3
AT 101 C	Survey of the Automobile	3
MGT 051 C	Basic Business Mathematics or	3
MGT 151 C	Business Mathematics	(3)
MGT 055 C	Business English or	3
MGT 111 C	Business Communications	(3)
Total Units Required		16

COLLISION REPAIR AUTOMOTIVE SALES AND SERVICE CERTIFICATE

Program Code: 1C31348

This program is designed to prepare students for customer service and sales positions in the automotive industry. It provides students with a basic knowledge of automobile operations, general maintenance requirements, damage appraisal procedures along with marketing and management principles. The certificate will enable students to work in a variety of non-technical areas in an automobile dealership, repair shop, or insurance company as a service representative, salesperson, or estimator. To earn a certificate, students must complete the required courses as listed with a minimum grade of "C" or higher. At least 50% of all course work must be completed at Cypress College.

Required courses are listed in suggested sequence:

Course#	Title	Units
ACR 012 C	Collision Damage Appraisal	3
AT 110 C	Automotive Fundamentals	4
MKT 094 C	Buyer Behavior	.5
MKT 097 C	Customer Relations	.5
MKT 208 C	Principles of Selling	3
MKT 222 C	Principles of Marketing	3
MGT 266 C	Human Relations in Business	3
Total Units		17

AUTOMOTIVE COLLISION CENTER DAMAGE APPRAISER CERTIFICATE

Program Code: 1C31350

The following program is designed to prepare students for employment as collision center damage appraisers. Training is given in both theory and practical application. Directed practical work is given in all areas of automotive damage appraisal. Additional training is incorporated to teach the basic selling skills needed to obtain employment in a modern collision facility. To earn a certificate, students must complete the required courses as listed with a minimum grade of "C." At least 50% of all course work must be completed at Cypress College.

Required courses are listed in suggested sequence:

Course#	Title	Units
AT 101 C	Survey of the Automobile	3
ACR 012 C	Automotive Damage Appraisal	3
ACR 013 C	Computerized Automotive Damage Appraisal	3
MKT 208 C	Principles of Selling	3
MGT 266 C	Human Relations in Business	3
MGT 151 C	Business Mathematics	3
Total Units		18

AUTO COLLISION REPAIR CENTER MANAGEMENT CERTIFICATE

Program Code: 1C31351

Combining Collision repair principles, managerial skills with business practices, this certificate program provides students with the necessary knowledge to effectively manage a modern collision repair facility. Students will gain a superior understanding of all collision repair facility functions. An emphasis is placed on developing the skill set to manage employees and a base knowledge of small business management. To earn a certificate, students must complete the required courses as listed with a minimum grade of "C." At least 50% of all course work must be completed at Cypress College.

Required courses are listed in suggested sequence:

Course#	Title	Units
ACR 011 C	Collision Refinishing Tech I	4.5
ACR 001 C	Auto Collision Repair Tech I	6
AT 101 C	Survey of the Automobile	3
MGT 261 C	Small Business Management	3
MGT 262 C	Principles of Management	3
MGT 266 C	Human Relations in Business	3
ACR 060 C	Collision Repair Management	3
ACR 012 C	Collision Damage Appraisal	3
ACR 013 C	Computerized Automotive Damage Appraisal	3
Total Units		31.5

**AUTOMOTIVE COLLISION CENTER
OFFICE MANAGEMENT Program Code: 1C31349**

This program is designed to prepare students for employment as office managers in a modern collision repair facility. Instruction is designed to give the students a general knowledge of the auto collision repair process. An emphasis is placed on developing the skill set to manage office employees and handle small business administration including human resource management. To earn a certificate, students must complete the required courses as listed with a minimum grade of “C” or higher. At least 50% of all course work must be completed at Cypress College.

Required courses are listed in suggested sequence:		Units
AT 101 C	Survey of the Automobile	3
ACR 013 C	Computerized Automotive Damage Appraisal	3
ACR 060 C	Collision Repair Management	3
CIS 075 C	Business Skills Development	3
MGT 266 C	Human Relations in Business	3
MGT 268 C	Human Resources Management	3
Total Units		18

**COLLISION REPAIR CENTER PARTS
MANAGER CERTIFICATE Program Code: 1C31347**

This curriculum is designed to prepare the student for employment in the field of collision center parts management. The program incorporates managing skills and techniques with basic collision center functions and operations with an emphasis on human relations in business. To earn a certificate, students must complete the required courses as listed with a minimum grade of “C” or higher. At least 50% of all course work must be completed at Cypress College.

Required courses are listed in suggested sequence:		Units
ACR 012 C	Collision Damage Appraisal	3
ACR 013 C	Computerized Automotive Damage Appraisal	3
AT 110 C	Automotive Fundamentals	4
MGT 266 C	Human Relations in Business	3
ACR 060 C	Collision Repair Management	3
CIS 125 C	Personal Typing/Keyboarding	2
Total Units		18

**DETAIL TECHNICIAN
CERTIFICATE Program Code: 1C31343**

This certificate will provide students with the knowledge necessary to enter the automotive detail trade with an emphasis on existing surface conditions, paint problems and their remedies. To earn a certificate, students must complete the required courses as listed with a minimum grade of “C” or higher. At least 50% of all course work must be completed at Cypress College.

Required courses are listed in suggested sequence:		Units
ACR 011 C	Collision Refinishing Tech I	4.5
ACR 011 C	Collision Refinishing Tech I	4.5
AT 101 C	Survey of the Automobile	3
ACR 020 C	Auto Detail/Car Care — Beg	3
ACR 021 C	Advanced Auto Detailing	3
Total Units		18

**AUTO COLLISION FACILITY PRODUCTION
MANAGER CERTIFICATE Program Code: 1C31352**

The Collision Facility Production Manager Program provides students with a career path for attaining the communication skills, practical knowledge and managerial insight necessary for pursuing a career as a collision facility production manager. Students completing this certificate will develop an understanding of the daily operations of a collision center and the management skills necessary to enhance operational work flow. To earn a certificate, students must complete the required courses as listed with a minimum grade of “C.” At least 50% of all course work must be completed at Cypress College.

Required courses are listed in suggested sequence:		Units
ACR 011 C	Auto Paint and Refinishing	4
ACR 001 C	Auto Collision Repair Tech I	6
ACR 020AC	Auto Detail/Car Care — Beg	2.5
ACR 060 C	Collision Repair Management	3
MGT 262 C	Principles of Management	3
Total Units		18.5

**COLLISION REPAIR I-CAR GOLD
CERTIFICATE Program Code: 1C31346**

The following program is designed to facilitate the student in acquiring the necessary knowledge and documentation to gain ICAR training points when entering the automotive collision repair industry. To earn a certificate, students must complete the required courses as listed with a minimum grade of “C” or higher. At least 50% of all course work must be completed at Cypress College.

Required courses are listed in suggested sequence:		Units
ACR 001 C	Auto Collision Repair Tech I	6
ACR 020 C	Auto Detail/Car Care — Beg	3
ACR 021 C	Advanced Auto Detailing	3
ACR 070 C	Automotive Color Matching	3
ACR 030 C	Electrical Systems and Component Repair	3
ACR 040 C	Structural Alignment Repair	4
Total Units		22

**COLLISION REPAIR
MECHANICAL TECHNICIAN
CERTIFICATE Program Code: 1C31345**

This program is designed to prepare students for employment in the field of collision repair with an emphasis on mechanical systems, electrical subsystems and supplemental restraint systems (SRS). Topics include bumper energy absorbing systems, automotive air conditioning, electrical test equipment, diagrams and schematics. To earn a certificate, students must complete the required courses as listed with a minimum grade of “C” or higher. At least 50% of all course work must be completed at Cypress College.

Required courses are listed in suggested sequence:		Units
ACR 001 C	Auto Collision Repair Tech I	6
ACR 030 C	Electrical Systems and Component Repair	3
AT 105 C	Basic Automotive Electricity	4
AT 115 C	Automotive Air Conditioning	4
ACR 050 C	Automotive Collision Special Projects	2–3
Total Units		19–20

COLLISION REPAIR PAINT APPLICATION SPECIALIST CERTIFICATE Program Code: 1C31344

This program is designed to prepare students for occupational competency in the automotive refinishing trade with an emphasis on color and application theory, matching solid, metallic and pearlescent colors. Topics include procedures, mixing equipment, surface preparation and topcoat application as well as general knowledge of the inner workings of the modern automobile. To earn a certificate, students must complete the required courses as listed with a minimum grade of "C" or higher. At least 50% of all course work must be completed at Cypress College.

Required courses are listed in suggested sequence:		Units
ACR 011 C	Collision Refinishing Tech I	4.5
ACR 020 C	Auto Detail/Car Care — Beg	3
ACR 021 C	Advanced Auto Detailing	3
ACR 050 C	Automotive Collision Special Projects	2–3
Total Units		12.5–13.5

ADVANCED COLLISION REPAIR PAINT TECHNICIAN CERTIFICATE Program Code: 1C31341

This certificate will provide students with the knowledge necessary to enter the automotive refinishing trade with an emphasis on management, staffing, organizing and controlling workflow. Topics include surface conditions and their remedies; substrate application and final topcoats; spot painting and blending techniques; clean up details; surface anomalies, their repairs; and car care. To earn a certificate, students must complete the required courses as listed with a minimum grade of "C" or higher. At least 50% of all course work must be completed at Cypress College.

Required courses are listed in suggested sequence:		Units
ACR 011 C	Auto Paint and Refinishing	4
ACR 011 C	Auto Paint and Refinishing	4
ACR 011 C	Auto Paint and Refinishing	4
ACR 070 C	Automotive Color Matching	3
ACR 020AC	Auto Detail/Car Care — Beg	2.5
MGT 262 C	Principles of Management	3
Total Units		20.5

ADVANCED COLLISION REPAIR — STRUCTURAL TECHNICIAN CERTIFICATE Program Code: 1C31332

Advanced Collision Repair — Structural Technician. This certificate will prepare the student for occupational competency in the field of structural alignment, with an emphasis on brakes and suspension. Training is given in both theory and practical application. Topics include structural restoration, gauge, universal and dedicated measuring systems. Wheel alignment, balance techniques, power steering, disc and drum brake systems are included. To earn a certificate, students must complete the required courses as listed with a minimum grade of "C" or higher. At least 50% of all course work must be completed at Cypress College.

Required courses are listed in suggested sequence:		Units
ACR 040 C	Structural Alignment Repair	4
AT 130 C	Auto Chassis and Brake Systems	12
ACR 050 C	Automotive Collision Special Projects	2–3
Total Units		18–19

Automotive Collision Repair (ACR)

ACR 001 C Auto Collision Repair Tech I 6 Units

Term hours: 80–90 lecture and 64–72 laboratory. This course covers principles and fundamentals of automotive collision repair with emphasis on tools of the trade and their proper use. Sheetmetal straightening and welding is covered in depth. \$20.00 Material Fee — Payable at Registration.

ACR 002 C Auto Collision Repair Tech II 6 Units

Prerequisite: ACR 001 C with a minimum grade of "C."

Term hours: 80–90 lecture and 64–72 laboratory. This course covers principles and fundamentals of automotive collision repair with emphasis on tools of the trade, their proper use, and metal working techniques, including auto body sheet metal welding. \$20.00 Material Fee — Payable at Registration.

ACR 003 C Auto Collision Repair Tech III 6 Units

Prerequisite: ACR 002 C with a minimum grade of "C."

Term hours: 80–90 lecture and 64–72 laboratory. This course will cover major body repairs with welded panel replacement, panel alignment, upholstery removal and replacement. Glass removal and replacement, advanced metal work, including straightening of frames. \$20.00 Material Fee — Payable at Registration.

ACR 004 C Auto Collision Repair Tech IV 6 Units

Prerequisite: ACR 003 C with a minimum grade of "C."

Term hours: 80–90 lecture and 64–72 laboratory. This course will cover major body repairs with welded panel replacement, panel alignment, upholstery removal and replacement. Glass removal and replacement, advanced metal work, including straightening of frames. \$20.00 Material Fee — Payable at Registration.

ACR 011 C Collision Refinishing Tech I 4.5 Units

Term hours: 64–72 lecture and 32–36 laboratory. In the first semester, students will learn the use of basic auto refinishing water base materials, equipment, procedures and techniques necessary to properly prepare and refinish the modern automobile. Subsequent semesters will teach students how to perform advanced prepping and painting of complete paint jobs and spot blending. In the final semester the students will learn the use of basic auto custom painting materials, equipment, procedures, and techniques necessary to properly prepare and paint automotive vehicles. \$20.00 Material Fee — Payable at Registration. May be taken for credit 3 times.

ACR 012 C Collision Damage Appraisal 3 Units

Term hours: 48–54 lecture. This course is designed to prepare students to enter the field of collision damage appraisal. Students will learn how to write repair estimates on damaged vehicles. The class will cover frame straightening, glass, paint and the use of various manuals.

ACR 013 C Computerized Automotive Damage Appraisal 3 Units

Prerequisite: ACR 012 C or equivalent, or minimum of one year estimating experience.

Term hours: 48–54 lecture. This course is designed for students who have had previous estimating training or some experience in automotive damage appraisal. Students will learn computer-based estimating software used in the collision repair industry. The course will give the student an opportunity to develop skills in computer-assisted estimate writing.

ACR 020 C Auto Detail/Car Care — Beginning 3 Units

Term hours: 32–36 lecture and 48–54 laboratory. This is an introductory automotive detailing and car care course. Detailing chemicals, processes, tools and equipment are covered in the class. Topics include the theory, diagnosis of paint conditions, and communication with the customer. Laboratory activities will emphasize skill competency in paint condition identification, washing, waxing, polishing and interior care.

ACR 021 C Advanced Auto Detailing 3 Units

Term hours: 32–36 lecture and 48–54 laboratory. This is an advanced course in automotive detailing and car care. Topics include: starting a detailing business, location determination, customer service, and advanced detailing techniques. Laboratory activities include receipt and delivery of customer vehicles, use of chemicals, and advanced detailing.

ACR 030 C Electrical Systems and Component Repair 4 Units

Prerequisite: Completion of or concurrent enrollment in ACR 002 C, ACR 003 C, or ACR 004 C; or employment in the industry.

Term hours: 64–72 lecture and 32–36 laboratory. This course will include advanced techniques in Auto Collision Repair. Topics included are: collision related electrical repairs, supplemental restraint systems (SRS), sheet mold compound (SMC), interior and exterior plastic repairs, plastic welding, bumper energy absorbing systems, air conditioning, sun roofs, aluminum repair and welding. Students are given practical applications for diagnosis, repair and servicing on both laboratory and live projects. \$20.00 Material Fee — Payable at Registration.

ACR 040 C Structural Alignment Repair 4 Units

Prerequisite: Completion of or concurrent enrollment in ACR 002 C, ACR 003 C, or ACR 004 C; or employment in the industry.

Term hours: 48–54 lecture and 48–54 laboratory. This course will emphasize the diagnosis and restructuring of the unitized automobile, light ruck frame and body, use of manuals, structural restoration, centerline gauge use, dedicated measurement systems, sectioning techniques, corrosion protection, relationship of suspension and structural components.

ACR 050 C Automotive Collision Special Projects 2 to 3 Units

Term hours: 16–18 lecture and 48–108 laboratory depending on units attempted. This course is designed to offer students a supervised independent program to continue and broaden their studies in automotive collision repairs. May be taken for credit 4 times.

ACR 055 C Automotive Collision — Work Experience — Vocational 1 to 4 Units

Prerequisite: Must be enrolled in seven units, including work experience. Concurrent enrollment in Automotive Collision Program.

Term hours: 16–18 lecture and additional requirements depending on units attempted. The course requires a minimum of five hours employment in an automotive collision related occupation per week. Refer to class schedule for an explanation of unit credit. May be taken for credit 4 times.

ACR 060 C Collision Repair Management 3 Units

Term hours: 48–54 lecture. This course is designed for those interested in pursuing a management track in the collision repair industry. Areas covered include: vehicle check in, vehicle movement/tracking, financial statement analysis, production management, insurance practices with collision repair facilities, Bureau of Automotive Repair rules, quality control methods, equipment purchase/lease decisions, shop layout and design, managing multiple stores, and new car dealership collision repair centers.

ACR 070 C Automotive Color Matching 3 Units

Term hours: 48–54 lecture. This course is an introduction to the concepts and techniques of matching color applied to automobiles. The course covers color, light, and vision theory, spraygun application techniques and extensive use of solid, metallic, and pearl color match exercises. The class will be using automotive paint mixing systems. The student will be required to provide certain safety and respiratory protection equipment.

ACR 298 C Automotive Collision Repair Seminar .5 to 12 Units

Prerequisite: May be required.

Corequisite: May be required.

Advisory: May be required.

Term hours: 0–216 lecture and/or 0–1080 laboratory depending on units attempted. This is a course for students who wish to increase their knowledge of automotive collision repair. Various topics will be offered. Unit credit may range from .5 to 12 units in any given semester. Consult the class schedule to verify credit for a particular semester. May be taken for credit 1–4 times. Pass/No Pass or Pass/No Pass/Letter Grade Option or Standard Letter Grade. Fees may be required — Payable at Registration. (CSU)

Automotive Technology

Division of Career Technical Education

Division Dean — Steve Donley

Faculty

John Alexander
Russell Bacarella
Michael Beard
Luciano Orozco
Michael Klyde

Toyota T-TEN Coordinator

Don Blanchard

Counselor

Jane Jepson

PROGRAM LEARNING OUTCOMES (PLOs)

Automotive Technology

Students who complete the Automotive Technology field of study will be able to develop the following skills required by the NATEF to enhance their employment opportunities and advance their career goals.

- Diagnose brake system, ABS systems, power booster systems, and suspension components; perform alignment; steering component diagnosis and repairs
- Utilize scan-tools, scopes DVOM's and other test equipment in troubleshooting engine and transmission derivability problems
- Diagnose fuel system problems; service emission controls; diagnose fuel injection and Powertrain Control Module problems
- Diagnose electrical system problems; use test meters; overhaul electrical components.
- Diagnose and repair manual transmission systems, drivelines, differentials and 4-wheel drive/all wheel drive systems.
- Diagnosis and repair automatic transmission/transaxle systems, torque converters.

- Diagnose and repair heating and air conditioning systems including automated systems.
- Learn the structure and functions of an internal combustion engine; perform engine overhaul processes and diagnosis of mechanical engine components.
- Develop mathematical skills to use in analytical problem solving.
- Function as a shop service manager, shop foreman, or supervisor; learn safety management.
- Operate a Computer Customer Records System; perform service manager functions.
- Develop effective communication skills in dealing with customers in a simulated automotive business structure.

ASSOCIATE IN SCIENCE DEGREE AUTOMOTIVE TECHNOLOGY

Program Code: 1S03771

The following program is designed to prepare students for employment as automotive technicians and in numerous other related areas of the automotive and transportation industry. Training is given in both theory and practical skills. Directed practical work is given in all areas of automotive maintenance and repair under simulated on-the-job conditions. The sequence in which courses are taken may be modified to meet individual needs.

To earn an Associate Degree students must complete: (1) all major course requirements with a minimum grade of "C"; (2) 25 units of General Education Graduation Requirements; (3) any elective courses to complete a minimum of 60 units; and, (4) have a minimum GPA of 2.0. At least 50% of all major course work must be completed at Cypress College.

Courses that fulfill major requirements for an Associate Degree at Cypress College might not be the same as those required for completing the major at a transfer institution offering a Baccalaureate Degree. For information on specific university requirements, please consult with your counselor, or visit the Transfer Center.

**Required courses are listed in suggested sequence:
Select 4 of the following 5 core Automotive Technology 12 unit courses
from the following:**

Course #	Title	Units
AT 120 C	Auto Engine Repair/Machining	12
AT 130 C	Auto Chassis and Brake Systems	12
AT 140 C	Auto Transmissions/Drivetrains	12
AT 150 C	Auto Performance/Driveability	12
AT 200 C	Electrical/Electronic Diag.	12
Total Units Required		48

Suggested electives — 25 units of general education course work with advisement from counselor.

AUTOMOTIVE TECHNOLOGY CERTIFICATE

Program Code: 1C21109

This program is designed to prepare students for employment as automotive technicians. Training is given in both theory and practical skills. Directed practical work is given in all areas of the automotive maintenance and repair under simulated on-the-job conditions. The program will provide the student the opportunity to acquire the knowledge and skills demanded of the modern automotive technician. The sequence in which courses are taken may be modified to meet individual needs. Primary emphasis is to prepare the student for occupational competency in automotive technology.

To earn a certificate, students must complete the required courses as listed with a minimum grade of "C." At least 50% of all course work must be completed at Cypress College.

Required courses are listed in suggested sequence. The student must take AT 160 Basic Electricity and then choose four of the five listed 12 units courses:

Course #	Title	Units
AT 105 C	Basic Automotive Electricity	4
AT 120 C	Auto Engine Repair/Machining	12
AT 130 C	Auto Chassis and Brake Systems	12
AT 140 C	Auto Transmissions/Drivetrains	12
AT 150 C	Auto Performance/Driveability	12
or		
AT 200 C	Electrical/Electronic Diag.	(12)
AT Select a minimum of 3 units from the elective courses listed below		3
Total Units Required		55

Electives

AT 050 C	Auto Tech/Special Projects	.5–3
AT 101 C	Survey of the Automobile	3
AT 110 C	Automotive Fundamentals	4
AT 115 C	Automotive Air Conditioning	4
AT 161 C	Diagnostics and Digital Meters	1
AT 162 C	Diagnostics and Digital Scopes	2
AT 163 C	Diagnostics and Scan-Tools	2
AT 164 C	Diagnostics and OBD II	2
AT 170 C	Basic Area Clean Air Car	5
AT 171 C	Advanced Clean Air Car Course	2
AT 180 C	Intro to Alternative Fuels	3
AT 181 C	Intro Electric/Hybrid Vehicles	2
AT 190 C	Toyota Engine Diagnosis/Repair	4
AT 191 C	Toyota Auto Trans Diag/Repair	6
AT 192 C	Toyota Manual Trans/Drivelines	4
AT 201 C	Toyota Basic Electrical 623	2
AT 202 C	Toyota Body Electrical 652	1
AT 203 C	Toyota Engine Controls 852	2
AT 204 C	Toyota Suspension Systems 452	1
AT 205 C	Toyota Brake Systems 552	1
AT 206 C	Toyota Air Conditioning 752	1
AT 207 C	Toyota Automatic Trans 262	1.5
AT 208 C	Toyota Manual Trans 302	1
AT 220 C	Lower Engine Blueprinting	2
AT 221 C	Upper Engine Blueprinting	2
AT 250 C	Adv Performance/Driveability	4
AT 298 C	Automotive Service Seminar	.5–3
MRN 060 C	Diesel Engines	6
MGT 266 C	Human Relations in Business	3

**AUTOMOTIVE TECHNOLOGY CERTIFICATE —
BRAKE AND ALIGNMENT
SPECIALIST**

Program Code: 1K12972

This program is designed to prepare students for employment as automotive brake and alignment technicians. Training is given in theory and practical skills. Directed practical work is given in areas of automotive maintenance and repair under simulated on-the-job conditions. Particular emphasis is placed on those competencies required of brake, suspension, and alignment technicians. The program will provide the student the opportunity to acquire the knowledge and skills demanded of the modern automotive brake, suspension, and alignment technician. The sequence in which courses are taken may be modified to meet individual needs.

To earn a certificate, students must complete the required courses as listed with a minimum grade of "C." At least 50% of all course work must be completed at Cypress College.

Required courses are listed in suggested sequence:

Course #	Title	Units
AT 130 C	Auto Chassis and Brake Systems	12
AT 105 C	Basic Automotive Electricity	4
Total Units Required		16

**AUTOMOTIVE TECHNOLOGY
CERTIFICATE — EMISSION CONTROL
SPECIALIST**

Program Code: 1K12973

This program is designed to prepare students for employment as an automotive emission control specialist. Training is given in theory and practical skills. Directed practical work is given in areas of automotive maintenance and repair under simulated on-the-job conditions. Particular emphasis is placed on those competencies required of emission control technicians. The program will provide the student the opportunity to acquire the knowledge and skills demanded of the modern automotive emission control specialist. The sequence in which courses are taken may be modified to meet individual needs.

To earn a certificate, students must complete the required courses as listed with a minimum grade of "C." At least 50% of all course work must be completed at Cypress College.

Required courses are listed in suggested sequence:

Course #	Title	Units
AT 050 C	Auto Tech/Special Projects	2
AT 105 C	Basic Auto Electricity	4
AT 170 C	Basic Area Clean Air Car	5
AT 171 C	Advanced Clean Air Car Course	2
AT 250 C	Adv Performance/Driveability	4
Total Units Required		17

**AUTOMOTIVE TECHNOLOGY CERTIFICATE —
ENGINE SPECIALIST**

Program Code: 1K12974

This program is designed to prepare students for employment as an automotive engine repair specialist. Training is given in theory and practical skills. Directed practical work is given in all areas of automotive maintenance and repair under simulated on-the-job conditions. Particular emphasis is placed on those competencies required of engine repair technicians and machinists. The program will provide the student the opportunity to acquire the knowledge and skills demanded of the modern automotive engine specialist. The sequence in which courses are taken may be modified to meet individual needs.

To earn a certificate, students must complete the required courses as listed with a minimum grade of "C." At least 50% of all course work must be completed at Cypress College.

Required courses are listed in suggested sequence:

Course #	Title	Units
AT 120 C	Auto Engine Repair/Machining	12
AT 105 C	Basic Automotive Electricity	4
Total Units Required		16

**AUTOMOTIVE TECHNOLOGY
CERTIFICATE — MAINTENANCE
TECHNICIAN**

Program Code: 1K30326

This program is designed to prepare students for employment as automotive maintenance technicians in dealerships and independent repair shops. Training is given in theory and practical skills. Directed practical work is given in all areas of automotive maintenance and repair under simulated on-the-job conditions. Particular emphasis is placed on those competencies required of maintenance technicians. The program will provide the student the opportunity to acquire the knowledge and skills demanded of the modern maintenance technician. The sequence in which courses are taken may be modified to meet individual needs.

To earn a certificate, students must complete the required courses as listed with a minimum grade of "C." At least 50% of all course work must be completed at Cypress College.

Required courses are listed in suggested sequence:

Course #	Title	Units
AT 110 C	Automotive Fundamentals	4
AT 105 C	Basic Automotive Electricity	4
AT 111 C	Automotive Quick Service	12
AT 130 C	Auto Chassis and Brake Systems	12
AT 150 C	Auto Performance/Driveability	12
Total Units Required		44

AUTOMOTIVE TECHNOLOGY CERTIFICATE — PERFORMANCE AND DRIVEABILITY SPECIALIST

Program Code: 1K12975

This program is designed to prepare students for employment as an automotive performance and driveability specialist. Training is given in theory and practical skills. Directed practical work is given in areas of automotive maintenance and repair under simulated on-the-job conditions. Particular emphasis is placed on those competencies required of performance and driveability technicians. The program will provide the student the opportunity to acquire the knowledge and skills demanded of the modern automotive performance and driveability specialist. The sequence in which courses are taken may be modified to meet individual needs.

To earn a certificate, students must complete the required courses as listed with a minimum grade of "C." At least 50% of all course work must be completed at Cypress College.

Required courses are listed in suggested sequence:

Course #	Title	Units
AT 150 C	Auto Performance/Driveability	12
AT 105 C	Basic Automotive Electricity	4
Total Units Required		16

AUTOMOTIVE SALES AND SERVICE CERTIFICATE

Program Code: 1K15688

This program is designed to prepare students for customer service and sales positions in the automotive industry. It provides students with a basic knowledge of automobile operations, general maintenance requirements, and damage appraisal procedures along with marketing and management principles. The certificate will enable students to work in a variety of non technical areas in an automobile dealership, repair shop, or insurance company as a service representative, salesperson, or estimator.

To earn a certificate, students must complete the required courses as listed with a minimum grade of "C." At least 50% of all course work must be completed at Cypress College.

Required courses are listed in suggested sequence:

Course#	Title	Units
AT 101 C	Survey of the Automobile or	3
AT 110 C	Automotive Fundamentals	(4)
ACR 012 C	Automotive Damage Appraisal	3
MKT 222 C	Principles of Marketing	3
MKT 208 C	Principles of Selling	3
MGT 266 C	Human Relations in Business	3
Total Units Required		15–16

AUTOMOTIVE TECHNOLOGY CERTIFICATE — SERVICE ADVISOR

Program Code: 1K30323

This program is designed to prepare students for employment as an automotive service advisor. Course work includes theory and operation of all automotive systems, the use of test instruments, and skill competency in the ability to write service work. The program will provide the student the opportunity to acquire the knowledge and skills demanded of the modern automotive service advisor. The sequence in which the courses are taken may be modified to meet individual needs.

To earn a certificate, students must complete the required courses as listed with a minimum grade of "C." At least 50% of all course work must be completed at Cypress College.

Required courses are listed in suggested sequence:

Course #	Title	Units
AT 101 C	Survey of the Automobile or	3
AT 110 C	Automotive Fundamentals	(4)
AT 105 C	Basic Automotive Electricity	4
AT 275 C	Automotive Svc Advisor Intern	4
AT 209 C	Toyota Portfolio TPORT	1–2
Total Units Required		12–14

AUTOMOTIVE TECHNOLOGY CERTIFICATE — TOYOTA TECHNICIAN CERTIFICATE

Program Code: 1K30324

This program is designed to prepare students for employment as an Toyota Technician. Training is given in theory and practical skills. Directed practical work is given in all areas of automotive maintenance and repair. Particular emphasis is placed on those competencies required of Toyota Technicians. The program will provide the student the opportunity to acquire the knowledge and skills demanded of the modern automotive technician working in a Toyota dealership. The sequence in which courses are taken may be modified to meet individual needs.

To earn a certificate, students must complete the required courses as listed with a minimum grade of "C." At least 50% of all course work must be completed at Cypress College.

Required courses are listed in suggested sequence:

Course #	Title	Units
AT 209 C	Toyota Portfolio TPORT	1–2
AT 211 C	Toyota Professional Series I	6
AT 212 C	Toyota Professional Series II	6
Total Units Required		13–14

AUTOMOTIVE TECHNOLOGY CERTIFICATE — TOYOTA SPECIALIST

Program Code: 1C16598

This program is designed to prepare students for employment as automotive technicians in Toyota dealerships. Training is given in theory and practical skills. Directed practical work is given in all areas of automotive maintenance and repair under simulated on-the-job conditions. Particular emphasis is placed on those competencies required of Toyota technicians. The program will provide the student the opportunity to acquire the knowledge and skills demanded of the modern Toyota technician. The sequence in which courses are taken may be modified to meet individual needs.

To earn a certificate, students must complete the required courses as listed with a minimum grade of "C." At least 50% of all course work must be completed at Cypress College.

Required courses are listed in suggested sequence:

Course #	Title	Units
AT 105 C	Basic Automotive Electricity	4
AT 115 C	Automotive Air Conditioning	4
AT 130 C	Auto Chassis and Brake Systems	12
AT 150 C	Auto Performance/Driveability	12
AT 190 C	Toyota Engine Diagnosis/Repair	4
AT 191 C	Toyota Auto Trans Diag/Repair	6
AT 192 C	Toyota Manual Trans/Drivelines	4
Total Units Required		46

**AUTOMOTIVE TECHNOLOGY
CERTIFICATE — TRANSMISSION
SPECIALIST**

Program Code: 1K12976

This program is designed to prepare students for employment as automotive transmission and power train specialist. Training is given in theory and practical skills. Directed practical work is given in areas of automotive maintenance and repair under simulated on-the-job conditions. Particular emphasis is placed on those competencies required of transmission and power train technicians. The program will provide the student the opportunity to acquire the knowledge and skills demanded of the modern automotive transmission and power train specialist. The sequence in which courses are taken may be modified to meet individual needs.

To earn a certificate, students must complete the required courses as listed with a minimum grade of "C." At least 50% of all course work must be completed at Cypress College.

Required courses are listed in suggested sequence:

Course #	Title	Units
AT 140 C	Auto Transmissions/Drivetrains	12
AT 105 C	Basic Automotive Electricity	4
Total Units Required		16

**ELECTRICAL DIAGNOSTIC
SPECIALIST**

Program Code: 1K30325

This program is designed to prepare students for employment as an automotive electrical system diagnostic specialist. Course work includes theory and operation of electrical systems, the use of test instruments, and skill competency in electrical system diagnosis and repair. The program will provide the student the opportunity to acquire the knowledge and skills demanded of the modern automotive electrical system specialist. The sequence in which the courses are taken may be modified to meet individual needs.

To earn a certificate, students must complete the required courses as listed with a minimum grade of "C." At least 50% of all course work must be completed at Cypress College.

Required courses are listed in suggested sequence:

Course #	Title	Units
AT 200 C	Electrical/Electronic Diag.	12
AT 105 C	Basic Auto Electricity	4
Total Units Required		16

**MOTORCYCLE PERFORMANCE TECHNICIAN
CERTIFICATE**

Program Code: 1K18810

This program is designed to provide technical skills and in-depth knowledge necessary for the student to enter the motorcycle maintenance and performance field with all the necessary skills to perform entry-level work, as well as to have a thorough understanding of theory so as to be qualified to participate in advanced training at the dealership or manufacturer.

To earn a certificate, students must complete the required courses as listed with a minimum grade of "C." At least 50% of all course work must be completed at Cypress College.

Required courses are listed in suggested sequence:

Course #	Title	Units
MT 100 C	Intro to Motorcycles	3
MT 101 C	Fuel, Lubrication and Cooling	4
MT 102 C	Motorcycle Electrical Systems	4
MT 140 C	Motorcycle Tune-up and Service	4
Total Units Required		15

Electives

MT 150 C	Motorcycle Dyno Operation	1.5
MT 110 C	Motorcycle Engine Theory	4
MT 120 C	Motorcycle Exhaust/Frame/Susp.	4
MT 130 C	Motorcycle Engine Overhaul	4
MT 160 C	Power Transmission Systems	4

Automotive Technology (AT)

**AT 050 C Special Projects —
Automotive Technology**

.5 to 3 Units

Term hours: 16–18 lecture and 24–162 laboratory TBA. This course will include supervised independent lab work on lab units and "live" vehicles. It is designed to allow the student to gain more practical experience repairing components and servicing automotive systems. Only approved project work will be allowed. May be taken for credit 3 times.

AT 100 C Technician Safety

1 Unit

Term hours: 16–18 lecture and 48–54 laboratory. This course covers the concepts and practices of a safe industrial work environment, including the use of tools and equipment, handling materials, rigging, fire prevention, power tools, accident investigation, personal protective equipment, hearing safety and the correct use of body mechanics will be covered. May be taken for credit 4 times. Pass/No Pass/Letter Grade Option. (CSU)

AT 101 C Survey of the Automobile

3 Units

Term hours: 48–54 lecture. This course provides fundamental knowledge of the automobile, including engines, power trains, suspension and brakes, electrical and fuel systems. Other areas of instruction will be in the use of tools and equipment normally used in automotive service and repair. (CSU)

AT 102 C Automotive History

3 Units

Term hours: 48–54 lecture. This course details the growth of the automotive industry in the U.S. from the late 1890s through the global business climate of today. Topics include biographical sketches of industry pioneers, geographical why's and where's of the industry, the roots of automotive design, and an in depth review of major engineering achievements. The course includes visits to historical automotive collections at a cost not to exceed \$40.00. (CSU)

AT 105 C Basic Automotive Electricity

4 Units

Term hours: 48–54 lecture and 48–54 laboratory. This course introduces the concepts of electrical systems and electronic control of the automobile. Areas covered will include basic electrical concepts, batteries, starting systems, charging systems, and body electrical diagnosis. Course instruction will consist of lecture, demonstration, web based learning with student application in the use of test equipment on simulator boards and "on-car" diagnosis with electrical wiring diagrams, charts, and schematics. \$15.00 Material Fee — Payable at Registration. (CSU)

AT 106 C Body Electrical Diagnosis 4 Units*Prerequisite: AT 105 C with a minimum grade of "B."*

Term hours: 48–54 lecture and 48–54 laboratory. This course covers the concepts of body electrical systems and electronic control of the automobile. Areas covered will include vehicle body electrical system diagnosis, batteries, starting systems, charging systems, extensive use of service information and wiring diagrams, and computer control of electronic systems. Course instruction will consist of lecture, demonstration, web based learning with student application in the use of test equipment on simulator boards and "on-car" diagnosis with electrical wiring diagrams, charts, and schematics. \$15.00 Material Fee — Payable at Registration. (CSU)

AT 110 C Automotive Fundamentals 4 Units

Term hours: 48–54 lecture and 48–54 laboratory. This course provides fundamental knowledge of the automobile, including engines, power trains, suspension and brakes, electrical and fuel systems. Other areas of instruction will be in the use of tools and equipment normally used in automotive service and repair. Emphasis will be on the operating principles, nomenclature of car care, inspection, preventive maintenance, and minor repair procedures. (CSU)

AT 111 C Automotive Quick Service 12 Units*Advisory: AT 110 C.*

Term hours: 144–162 lecture and 144–162 laboratory. This course covers the essential content and skill practice for a technician to perform quick service skills including, shop safety, correct use of required tools, service information use, repair order write up/documentation, vehicle inspection, oil change, fluid flush and other quick service maintenance work. (CSU)

AT 115 C Automotive Air Conditioning 4 Units

Term hours: 48–54 lecture and 48–54 laboratory. This course emphasizes the acquisition of the practical skills needed to both understand principles of refrigeration and perform system diagnosis and repair. Demonstrated lecture, shop lab simulators and "live" vehicles will be used to learn service diagnosis, repair and installation of air conditioning systems including automatic temperature control. Safety and environmental concerns along with CFC recovery, recycling, retrofitting, and R-134A will be covered. (CSU)

AT 120 C Auto Engine Repair/Machining 12 Units*Advisory: AT 101 C or AT 110 C.*

Term hours: 144–162 lecture and 144–162 laboratory. This course covers the acquisition of practical skills needed for accurate internal combustion engine diagnosis and repair and all phases of engine rebuilding machine work. Demonstrated lecture, simulated problem diagnosis, and practical application on "live" vehicles will be used. Individualized instruction on Automotive rebuilding tools and machinery is an integral part of this course. Engine theory, design, repair, practical and theoretical high performance modifications are part of the course. Preparation for ASE certification tests A1, MQ1, MG2, and MG3 will be covered. \$15 Material Fee — Payable at Registration. (CSU)

AT 130 C Auto Chassis and Brake Systems 12 Units*Prerequisite: Completion of or concurrent enrollment in AT 110 C.*

Term hours: 144–162 lecture and 144–162 laboratory. This course emphasizes the design, operating principles, service, repair and diagnosis of chassis and brake systems used on today's vehicles. Major topics of study will be wheel alignment procedures, tire and wheel balance, suspension and steering, system repair, hydraulics, and brake system service and repair. Application will be applied under simulated repair shop procedures using "live" vehicles. Preparation for ASE (A4 and A5) certification will be covered. \$15 Material Fee — Payable at Registration. (CSU)

AT 140 C Auto Transmissions/Drivetrains 12 Units*Advisory: AT 101 C or AT 105 C or AT 110 C.*

Term hours: 144–162 lecture and 144–162 laboratory. This course will include operation principles, design, repair, overhaul and service procedures of automatic transmissions, 4 and 5 speed synchromesh transmissions, clutch assemblies, drive lines, final drive axles and trans-axle units. Demonstrated lectures and shop laboratory work on automatic transmissions will be covered with emphasis on procedures to industry standards. Practical application will be under simulated shop conditions on "live" vehicles. Preparation of ASE certification will be covered. \$15 Material Fee — Payable at Registration. (CSU)

AT 150 C Auto Performance/Driveability 12 Units*Advisory: AT 101 C or AT 105 C or AT 110 C.*

Term hours: 144–162 lecture and 144–162 laboratory. This course will include operating principles, design, and repair procedures of the computerized engine management system and the application of related diagnostic tools and equipment. In addition, alternators, starters, batteries, ignition systems, emission control systems, 5 gas analysis, and scan tool use will be covered. Skill competency development will be under simulated shop conditions on "live" vehicles. Preparation for ASE certification test A8 will be covered. \$15 Material Fee — Payable at Registration. (CSU)

AT 161 C Diagnostics and Digital Meters 1 Unit

Term hours: 16–18 hours. This course covers concepts of testing electrical and electronic circuits of an automobile using a multi-meter. Advanced diagnostic concepts and circuit testing of automobile systems is a large component of the course. Demonstrated lecture in conjunction with collaborative work groups is emphasized. Practical application in the use of multi-meters on live circuits and simulator boards is an integral part of the course. (CSU)

AT 162 C Diagnostics and Digital Scopes 2 Units

Term hours: 24–27 lecture and 24–27 laboratory. This course includes advanced principles and procedures of power train control diagnosis. Demonstrated lectures in conjunction with shop laboratory work using digital storage oscilloscopes is included. Practical application under simulated shop conditions on "live" vehicles is an integral component of this course. Topics include lab scope functions, sensor evaluation and analysis, actuator diagnosis and circuit testing. (CSU)

AT 163 C Diagnostics and Scan-Tools 2 Units

Term hours: 24–27 lecture and 24–27 laboratory. This course emphasizes diagnostic strategies, repair and service of power-train control systems using scan-tools. Demonstrated lecture in combination with shop laboratory activities using a variety of scan-tools is included. Practical application on "live" vehicles is an integral part of the course. Topics include testing engine control systems, diagnostic trouble codes, data streams, OBD I and OBD II systems. (CSU)

AT 164 C Diagnostics and OBD II (formerly AT 094 C) 2 Units

Term hours: 24–27 lecture and 24–27 laboratory. This course emphasizes operating principles, diagnostic strategies and repair procedures of the OBD II system. Demonstrated lecture in conjunction with shop laboratory work are emphasized. Practical application on laboratory vehicles is an integral component of the course. This course meets Bureau of Automotive Repair requirements for smog check technician licensing. (CSU)

AT 170 C Basic Area Clean Air Car 5 Units

Term hours: 80–90 lecture. This course prepares students for the State of California Licensed Smog Check Mechanic Test. Modern diagnostic equipment including BAR 97 chassis dynamometer will be used in sessions. (CSU)

AT 171 C Advanced Clean Air Car Course 2 Units

Term hours: 32–36 lecture. This course covers operating procedures, diagnostic strategies, and repair procedures for loaded mode emissions testing. Course emphasizes baseline techniques, five gas analysis and lab scope use. Course meets California BAR Smog Check licensing requirements. (CSU)

AT 180 C Introduction to Alternative Fuels 3 Units

Term hours: 48–54 lecture and 16–18 laboratory. This course is an introductory course on alternative fuels as used in the transportation industry. Various fuels will be compared, with an emphasis on compressed natural gas. Topics include the theory, design, operation, conversion, diagnosis, and repair of gaseous fuel systems. Laboratory activities will emphasize skill competency in vehicle preparation, fuel system conversion and the diagnosis and repair of alternative fuel vehicles. (CSU)

AT 181 C Introduction to Electric/Hybrid Vehicles 2 Units

Term hours: 32–36 lecture and 16–18 laboratory. This course is an introductory course in electric (EV) and electric/hybrid vehicles as used in the transportation industry. Topics include the theory, design, operation, maintenance, and repair of batteries, motors, controllers, chargers, and regenerative braking systems. Technician safety is also covered. (CSU)

AT 190 C Toyota Engine Diagnosis/Repair 4 Units

Term hours: 48–54 lecture and 48–54 laboratory. This course covers the design, operation, diagnosis, and repair of Toyota engines. Emphasis is on the mastery of job skills commonly required to succeed at the dealership level. Learning strategies include: demonstrated lecture; simulated problem diagnosis; practical application on “live” vehicles; group and individual activities. Preparation for ASE and Toyota certification will be covered. (CSU)

AT 191 C Toyota Auto Trans Diag/Repair 6 Units

Term hours: 64–72 lecture and 96–108 laboratory. This course covers the design, operation, diagnosis, and repair of Toyota automatic transmissions. Emphasis is on the mastery of job skills commonly required to succeed at the dealership level. Learning strategies include: demonstrated lecture; simulated problem diagnosis; practical application on “live” vehicles; group and individual activities. Preparation for ASE and Toyota certification will be covered. (CSU)

AT 192 C Toyota Manual Trans/Drivelines 4 Units

Term hours: 48–54 lecture and 48–54 laboratory. This course covers the design, operation, diagnosis, and repair of Toyota manual transmissions, and drivelines. Emphasis is on the mastery of job skills commonly required to succeed at the dealership level. Learning strategies include: demonstrated lecture; simulated problem diagnosis; practical application on “live” vehicles; group and individual activities. Preparation for ASE and Toyota certification will be covered. (CSU)

AT 195 C Automotive Service Advisor 4 Units

Advisory: AT 110 C.

Term hours: 48–54 lecture and 48–54 laboratory. This is a course in the concepts and application of the Service Advisor's job duties primarily as they apply to job skills required in the service department of new vehicle dealerships. Course instruction will include lecture, role playing, repair order writing, interactive computer based assignments, use of dealer management software, site visits and demonstration of knowledge in a simulated work environment. (CSU)

AT 200 C Electronic/Electrical Diagnostics 12 Units

Prerequisite: AT 105 C with a minimum grade of “C.”

Advisory: AT 150 C.

Term hours: 160–180 lecture and 128–144 laboratory. This course emphasizes operating principles, design and repair procedures of automotive electrical/electronic systems. In addition, lighting systems, power windows, power door locks, under dash components, charging systems, starters, batteries, and computerized engine management systems will be covered. Modern test equipment such as engine analyzers, lab scopes, scan-tools, and electrical/electronic analyzers will be used. Skill competency development will be simulated under shop conditions on OBD II and newer vehicles. \$15 Material Fee — Payable at Registration. (CSU)

AT 201 C Toyota Basic Electrical 623 2 Units

Term hours 32–36 lecture. This course is designed to give a basic understanding of Toyota electrical concepts and troubleshooting techniques, and to give in-depth knowledge of the operation, diagnosis, and repair of the battery, starting, and charging system. (CSU)

AT 202 C Toyota Body Electrical 652 1 Unit

Term hours: 16–18 lecture. This course is designed to familiarize the technician with a basic understanding of Toyota body electrical concepts and troubleshooting techniques, and to give them in-depth knowledge of the operation, diagnosis, and repair of body computer systems on the vehicle-supplemental restraint systems included. (CSU)

AT 203 C Toyota Engine Controls 852 2 Units

Term hours: 32–36 lecture. This course is designed to familiarize the technician with a basic understanding of theory, training, and operation of the Toyota engine control systems. Diagnosis and troubleshooting are covered. (CSU)

AT 204 C Toyota Suspension Systems 452 1 Unit

Term hours: 16–18 lecture. This course is designed to familiarize the technician with information regarding Toyota suspension components and suspension design, alignment geometry and types of wheel alignment, pre-alignment inspection, Toyota electrical modulated suspensions and noise vibration harshness. (CSU)

AT 205 C Toyota Brake Systems 552 1 Unit

Term hours: 16–18 hours. This course is designed to familiarize the technician with Toyota information regarding the following: brake system components, operation and adjustments, disc and drum refinishing, anti-lock brake systems, diagnosis and testing of ABS and actuator checker operation. (CSU)

AT 206 C Toyota Air Conditioning 752 1 Unit

Term hours: 16–18 lecture. This course is designed to familiarize the technician with fundamental operating principles of the Toyota automotive climate control systems including components, operation, and servicing. Handling of R-12 and R-134 will be included. (CSU)

AT 207 C Toyota Automatic Trans 262 1.5 Units

Term hours: 24–27 lecture. This course is designed to familiarize the technician with the operation of Toyota automatic transmissions. Both rear wheel drive and front wheel drive transmissions are covered. This course also covers the operation, diagnosis and service of the torque converter, planetary gear train and holding devices and the valve body. (CSU)

AT 208 C Toyota Manual Trans 302 1 Unit

Term hours: 16–18 lecture. This course is designed to familiarize the technician with Toyota manual transmissions and transaxles. Topics include: drive nuts, manual transmissions and transaxles. Factory manuals, tools and components are utilized. (CSU)

AT 209 C Toyota Portfolio TPORT .5 Units

Term hours: 16–18 lecture. This course tracks the progress of T-TEN students through the program. This course will also prepare the student for placement in the dealership internship. This course must be taken every semester the student is in the T-TEN program. (CSU)

AT 210 C Toyota Hybrid Vehicles .5 Units

Term hours: 16–18 lecture. This course is designed to familiarize experienced technicians with operating principles of the Toyota Hybrid System. This course will emphasize service, repair and diagnostic procedures for the Toyota Prius power-train system. Specialized emission control equipment, fuel tank, brake system, and electric power steering operation as they relate to the hybrid system will be covered. (CSU)

AT 211 C Toyota Professional Series I 6 Units

Term hours: 96–108 lecture. This course is designed to familiarize the technician with a basic understanding in three of the Toyota training course; Basic Electrical (623), Body Electrical (653), Engine Controls (852) and Hybrid Vehicles. Diagnosis and Troubleshooting are covered. \$15.00 Material Fee — Payable at Registration. (CSU)

AT 212 C Toyota Professional Series II 6 Units

Term hours: 96–108 lecture. This course is designed to familiarize the technician with a basic understanding of Toyota Suspension Systems (453), Toyota Brake Systems (553), Toyota Air Conditioning (752), Toyota Automatic Transmissions (274), Toyota Manual Transmissions (302). Diagnosis and Troubleshooting are covered. \$15.00 Material Fee — Payable at Registration. (CSU)

AT 215 C ASE Test Prep — Heating and A/C .5 Units

Term hours: 8–9 lecture. This is a review course and is designed to help prepare students to take and pass the ASE (National Institute for Automotive Service Excellence) heating and air conditioning certification test. This course will review the various task lists which detail the knowledge that a technician must have to pass the ASE heating and air conditioning certification test. Demonstrated lecture will include instruction concerning theory, operation, diagnosis, and repair of automotive climate control systems. May be taken for credit 4 times. (CSU)

AT 220 C Lower Engine Blueprinting 2 Units

Term hours: 32–36 lecture. The course emphasizes the design, operation, and modification of modern engines. Students will learn how to use formulas, and software to design and modify the lower engine assembly. Students will also learn how to use precision tools to measurements in accordance with blueprint specifications. (CSU)

AT 221 C Upper Engine Blueprinting 2 Units

Term hours: 32–36 lecture. This course emphasizes the design, operation, and modification of modern engines. Students will learn how to use formulas, and software to design and modify the upper engine assembly. Students will also learn how to modify and prepare cylinder heads, intake systems and exhaust systems to optimize engine performance. (CSU)

AT 225 C ASE Test Prep — Engine Repair .5 Units

Term hours: 8–9 lecture. This is a review course and is designed to help prepare students to take and pass the ASE (National Institute for Automotive Service Excellence) engine repair certification test. This course will review the various task lists which detail the knowledge that a technician must have to pass the ASE engine repair certification test. Demonstrated lecture will include instruction concerning theory, operation, diagnosis, and repair of the automotive engine. May be taken for credit 4 times. (CSU)

AT 235 C ASE Test Prep — Brakes .5 Units

Term hours: 8–9 lecture. This is a review course and is designed to help prepare students to take and pass the ASE (National Institute for Automotive Service Excellence) brake certification test. This course will review the various task lists which detail the knowledge that a technician must have to pass the ASE brake certification test. Demonstrated lecture will include instruction concerning theory, operation, diagnosis, and repair of the automotive brake systems. May be taken for credit 4 times. (CSU)

AT 236 C ASE Test Prep — Steering/Susp .5 Units

Term hours: 8–9 lecture. This is a review course and is designed to help prepare students to take and pass the ASE (National Institute for Automotive Service Excellence) steering and suspensions certification tests. This course will review the various task lists which detail the knowledge that a technician must have to pass the ASE steering and suspension certification test. Demonstrated lecture will include instruction concerning theory, operation, diagnosis, and repair of the automotive steering and suspension systems. May be taken for credit 4 times. (CSU)

AT 245 C ASE Test Prep — Manual Trans .5 Units

Term hours: 8–9 lecture. This is a review course and is designed to help prepare students to take and pass the ASE (National Institute for Automotive Service Excellence) manual transmission and drive-train certification tests. This course will review the various task lists which detail the knowledge that a technician must have to pass the ASE manual transmission certification test. Demonstrated lecture will include instruction concerning theory, operation, diagnosis, and repair of manual transmission and drive-train systems. May be taken for credit 4 times. (CSU)

AT 246 C ASE Test Prep — Automatic Trans .5 Units

Term hours: 8–9 lecture. This is a review course and is designed to help prepare students to take and pass the ASE (National Institute for Automotive Service Excellence) automatic transmission certification test. This course will review the various task lists which detail the knowledge that a technician must have to pass the ASE automatic transmission certification test. Demonstrated lecture will include instruction concerning theory, operation, diagnosis, and repair of automatic transmission. May be taken for credit 4 times. (CSU)

AT 250 C Adv Performance/Driveability 4 Units

Term hours: 64–72 lecture and 32–36 laboratory. The course includes advanced principles, design and repair procedures of automotive electrical, ignition and computerized engine management systems, including emission controls. Demonstrated lectures and laboratory work using modern testing equipment, oscilloscopes, dynamometer and other diagnostic equipment are included. Practical application under simulated repair shop conditions on “live” vehicles is an integral part of the course. (CSU)

AT 255 C ASE Test Prep — Engine Perf .5 Units

Term hours: 8–9 lecture. This is a review course and is designed to help prepare students to take and pass the ASE (National Institute for Automotive Service Excellence) engine performance certification test. This course will review the various task lists which detail the knowledge that a technician must have to pass the ASE engine performance certification test. Demonstrated lecture will include instruction concerning theory, operation, diagnosis, and repair of automotive engine. May be taken for credit 4 times. (CSU)

AT 256 C ASE Test Prep — Adv Engine Perf .5 Units

Term hours: 8–9 lecture. This is a review course and is designed to help prepare students to take and pass the ASE (National Institute for Automotive Service Excellence) advanced engine performance certification test. This course will review the various task lists which detail the knowledge that a technician must have to pass the ASE advanced engine performance certification test. Demonstrated lecture will include instruction concerning theory, operation, diagnosis, and repair of automotive engine control systems. May be taken for credit 4 times. (CSU)

AT 265 C ASE Test Prep — Electrical .5 Units

Term hours: 8–9 lecture. This is a review course and is designed to help prepare students to take and pass the ASE (National Institute for Automotive Service Excellence) electrical certification test. This course will review the various task lists which detail the knowledge that a technician must have to pass the ASE electrical certification test. Demonstrated lecture will include instruction concerning theory, operation, diagnosis, and repair of automotive electrical systems. May be taken for credit 4 times. (CSU)

AT 295 C Automotive Internship 1 to 4 Units

Term hours: 16–18 lecture and 54–240 laboratory depending on units attempted. This course is designed to give the student credit for work experience at a related occupational worksite, while being concurrently enrolled in a vocational major. For each unit of credit, a minimum of 75 total hours of worksite hours for paid internships (minimum 60 hours for unpaid internships). The internship allows students to apply knowledge gained in college courses to an actual work setting, sample career choices and improve job-readiness skills. Supplemental reading and course assignments required. May be taken for credit 1–4 times. Open Entry/Open Exit. Pass/No Pass or Pass/No Pass/Letter Grade Option or Standard Letter Grade. (CSU)

AT 298 C Automotive Service Seminar .5 to 12 Units

Prerequisite: May be required.

Corequisite: May be required.

Advisory: May be required.

Term hours: 0–216 lecture and/or 0–648 laboratory depending on units attempted. This is a course for students who wish to increase their knowledge of automotive repair. Various topics will be offered. Unit credit may range from .5 to 12 units in any given semester. Consult the class schedule to verify credit for a particular semester. May be taken for credit 1–4 times. Pass/No Pass or Pass/No Pass/Letter Grade Option or Standard Letter Grade. Fee may be required — Payable at Registration. (CSU)

Motorcycle Technology (MT)**MT 100 C Introduction to Motorcycles 3 Units**

Term hours: 48–54 lecture and 16–18 laboratory. This course is an introduction to motorcycles, motorcycle design and maintenance theory. The course offers a view of the history of motorcycles as well as a discussion of modern machines. It gives the student an overview of the theory of operation and design principles involved in motorcycle maintenance. (CSU)

MT 101 C Fuel, Lubrication and Cooling 4 Units

Term hours: 48–54 lecture and 32–36 laboratory. This course covers the principles, theory of operation, design, and function of motorcycle fuel, lubrication and cooling systems as well as inspection, disassembly, cleaning, measuring and rebuilding of the components of those systems. Upon completion of the course the student will be able to perform preventative maintenance, troubleshoot discrepancies, repair the system components and assist customers in selecting suitable aftermarket parts in both dealer and independent shop settings. (CSU)

MT 102 C Motorcycle Electrical Systems 4 Units

Term hours: 48–54 lecture and 32–36 laboratory. This course covers the principles of basic electricity including terms, circuits, wiring diagrams and symbols, magnetism and methods of providing electrical energy for motorcycles. Various electrical components of generation, regulation, distribution, control, switching, and methods of testing of motorcycle electrical systems will be discussed as well. Further, ignition systems and how they relate to the engine components will be covered. (CSU)

MT 110 C Motorcycle Engine Theory 4 Units

Term hours: 48–54 lecture and 32–36 laboratory. This course offers a comprehensive view of how two- and four-stroke motorcycle engines work through detailed discussion of the theory of operation and technical principles involved in converting fuel to motion. This course is also appropriate for technical and non-technical students who are interested in understanding any modern internal combustion engine. (CSU)

MT 120 C Motorcycle Exhaust/Frame/Suspension 4 Units

Term hours: 48–54 lecture and 32–36 laboratory. This course covers the theory, design and function of motorcycle exhaust systems, various frame and suspension designs, tires, cast and spoked wheels, and both disk and drum brakes. Upon successful completion of this course, the student will be able to perform preventive maintenance, troubleshoot discrepancies, repair the systems and assist customers in selecting suitable aftermarket parts in both a dealer and independent shop setting. (CSU)

MT 130 C Motorcycle Engine Overhaul 4 Units

Term hours: 48–54 lecture and 32–36 laboratory. This course offers a comprehensive view of the parameters determining the need for overhaul of modern motorcycle engines, the methods and techniques involved and the adjustments and operations check afterwards. Further, it covers the use of overhaul and parts manuals and the logic employed in them. Upon the successful completion of this class, a student will be able to perform a complete overhaul of the various types of modern motorcycle engines including water-cooled, multi-valve engines as well as air-cooled V-twins. The student will be able to advise the customer about sensible performance modifications. (CSU)

MT 140 C Motorcycle Tune-up and Service 4 Units

Term hours: 48–54 lecture and 32–36 laboratory. This course covers motorcycle tune-up, general service, ignition and valve adjustment, lubrication and oil and filter changes as well as the special tools required. It covers service and parts manuals, micro-fiche and computerized manuals and the logic employed in them. Upon successful completion of this class the student will be able to perform virtually all aspects of scheduled maintenance including tune-ups, valve adjustment, oil changes and lubrication service as well as troubleshoot and repair common maintenance discrepancies. (CSU)

MT 150 C Motorcycle Dyno Operation 1.5 Units

Term hours: 16–18 lecture and 24–27 laboratory. This is an in-depth course covering motorcycle engine and component theory and function as related to dynamometer operation. It covers use of a dyno for data acquisition for successful maintenance discrepancy, diagnosis, and correction. Various motorcycles will be run on the dyno so students can use the data to troubleshoot maintenance problems. (CSU)

MT 160 C Power Transmission Systems 4 Units

Term hours: 48–54 lecture and 32–36 laboratory. This course covers motorcycle power transmission systems from the engine crankshaft through the clutch, transmission, and final drive system to the rear wheel. The theory of operation including lubrication requirements, gear ratios, design and function of the primary drive, the clutch, the transmission and final drive will be covered. Clutches, transmissions and drive systems will be removed, disassembled, cleaned, inspected, measured, rebuilt, reinstalled and checked for proper operation. (CSU)

Aviation

Division of Career Technical Education

Division Dean — Steve Donley

Faculty

Kathleen Reiland

Counselor

Jane Jepson

PROGRAM LEARNING OUTCOMES (PLOs)

Aviation

Students who receive a certificate from the Cypress College Aviation Program

- Will have acquired the specified set of skills required for aviation employment opportunities
- Will have achieved the necessary competencies to enter the aviation field
- Will be aware of additional educational and career opportunities within aviation

ASSOCIATE IN SCIENCE DEGREE

AVIATION MANAGEMENT Program Code: 1S03772

The Aviation Management Program provides students with a career path for attaining the foundational skills, practical knowledge, and technical training for pursuing a career in aviation management. Students completing this degree will develop advanced understanding of the safety, security, service, and regulatory requirements necessary to work in aviation management.

To earn an Associate Degree students must complete all graduation requirements to include: (1) all major course requirements with a minimum grade of "C" or better; (2) 25 units of General Education Graduation Requirements; (3) the cultural diversity and reading requirements; (4) any elective courses to complete a minimum of 60 units; and, (5) have a minimum GPA of 2.0. At least 50% of all major course work must be completed at Cypress College. Courses that fulfill major requirements for an Associate Degree at Cypress College might not be the same as those required for completing the major at a transfer institution offering a Baccalaureate Degree. For information on specific university requirements, please consult with your counselor, or visit the Transfer Center.

Required courses are listed in suggested sequence:		Units
AVIA 100 C	Introduction to Aviation	3
	or	
AVIA 132 C	Private Pilot	(4)
AVIA 102 C	Career Communication/Portfolio	3
	or	
ATC 102 C	Career Communication/Portfolio	(3)
AVIA 104 C	Air Transportation	3
	or	
ATC 270 C	Airline Operations	(3)
AVIA 112 C	Airline/Aviation Management	3
AVIA 256 C	Crew Resource Management	3
	or	
ATC 256 C	Crew Resource Management	(3)
ATC 112 C	Homeland Security	3
ATC 118 C	Disaster Preparedness/Response	3
ATC 183 C	Customer Care: Airline/Travel	3

Electives: To complete all major course requirements, students must complete 10 or 11 elective units from the list below for a total of 35 units.

	Units	
AVIA 116 C	Aviation Law	3
AVIA 136 C	Air Navigation	3
AVIA 140 C	Meteorology	3
AVIA 144 C	Aircraft and Engines	3
AVIA 148 C	Air Traffic Control	3
AVIA 232 C	Instrument Rating	3
AVIA 295 C	Aviation Internship	3
	or	
ATC 295 C	Airline/Travel Internship	(3)
AVIA 299 C	Independent Study	.5–2
	or	
ATC 299 C	Independent Study	(.5–2)
ATC 114 C	Investigative Documentation	3
ATC 116 C	Aviation/Trans Security	3
ATC 182 C	Cultural Tourism	3
ATC 191 C	Airline Reservations: APOLLO	3
ATC 192 C	Airline Reservations: SABRE	3
ATC 278 C	Public Relations	3
	Total Units	35

AVIATION MANAGEMENT CERTIFICATE

Program Code: 1C31187

The Aviation Management Program provides students with a career path for attaining the foundational skills, practical knowledge, and technical training necessary for pursuing a career in aviation management. Students completing this certificate will develop an advanced understanding of the safety, security, service and regulatory requirements necessary to work in aviation management. To earn this certificate, complete the required courses with a minimum grade of "C." At least 50% of all course work must be completed at Cypress College.

Required courses are listed in suggested sequence.		Units
AVIA 100 C	Introduction to Aviation	3
	or	
AVIA 132 C	Private Pilot	(4)
AVIA 102 C	Career Communication/Portfolio	3
	or	
ATC 102 C	Career Communication/Portfolio	(3)
AVIA 104 C	Air Transportation	3
	or	
ATC 270 C	Airline Operations	(3)
AVIA 112 C	Airline/Aviation Management	3
AVIA 256 C	Crew Resource Management	3
	or	
ATC 256 C	Crew Resource Management	(3)
ATC 112 C	Homeland Security	3
ATC 118 C	Disaster Preparedness/Response	3
ATC 183 C	Customer Care: Airline/Travel	3

Electives: To complete all major course requirements, students must complete 10 or 11 elective units from the list below for a total of 35 units.

	Units
AVIA 116 C Aviation Law	3
AVIA 136 C Air Navigation	3
AVIA 140 C Meteorology	3
AVIA 144 C Aircraft and Engines	3
AVIA 148 C Air Traffic Control	3
AVIA 232 C Instrument Rating	3
AVIA 295 C Aviation Internship	3
	or
ATC 295 C Airline/Travel Internship	(3)
AVIA 299 C Independent Study	.5–2
	or
ATC 299 C Independent Study	(.5–2)
ATC 114 C Investigative Documentation	3
ATC 116 C Aviation/Trans Security	3
ATC 182 C Cultural Tourism	3
ATC 191 C Airline Reservations: APOLLO	3
ATC 192 C Airline Reservations: SABRE	3
Total Units	35

**ASSOCIATE IN SCIENCE DEGREE
COMMERCIAL PILOT Program Code: 1S03773**

This curriculum is designed to prepare the student to fly commercial, executive, and/or light aircraft as a pilot or instructor.

To earn an Associate Degree students must complete: (1) all major course requirements with a minimum grade of “C”; (2) 25 units of General Education Graduation Requirements; (3) the cultural diversity and reading requirements; (4) any elective courses to complete a minimum of 60 units; and, (5) have a minimum GPA of 2.0. At least 50% of all major course work must be completed at Cypress College.

Courses that fulfill major requirements for an Associate Degree at Cypress College might not be the same as those required for completing the major at a transfer institution offering a Baccalaureate Degree. For information on specific university requirements, please consult with your counselor, or visit the Transfer Center.

Required courses are listed in suggested sequence:

Course #	Title	Units
AVIA 102 C	Career Communication/Portfolio	3
AVIA 104 C	Air Transportation	3
	or	
ATC 270 C	Airline Operations	(3)
AVIA 132 C	Private Pilot	4
AVIA 136 C	Air Navigation	3
AVIA 140 C	Meteorology	3
AVIA 144 C	Aircraft and Engines	3
AVIA 196 C	Ground Trainer Lab — Instrument Flight	1
AVIA 232 C	Instrument Rating	3
AVIA 240 C	Commercial Pilot Seminar	3
AVIA 244 C	Aviation Instructor	3
AVIA 256 C	Crew Resource Management	3
	Elective Units	4
Total Units Required		36

Electives: To complete all major course requirements, students must complete 4 elective units from the list below for a total of 36 units.

	Units
AVIA 050 C Special Projects — Aviation	2
AVIA 112 C Airline/Aviation Management	3
AVIA 148 C Air Traffic Control	3
AVIA 152 C Glider Theory	3
AVIA 189 C Flight Training Device — Intro	.5
AVIA 190 C Flight Training — Private Pilot	2
AVIA 191 C Flight Training — Instrument Rating	2
AVIA 192 C Flight Training — Commercial Pilot	2
AVIA 193 C Flight Training — Flight Instructor	1–5
AVIA 197 C Ground Trainer Lab — Glass Cockpit	1
AVIA 250 C Turbine Simulator Observation	.5
AVIA 255 C Turbine Simulator Orientation	.5
AVIA 295 C Aviation Internship	3
AVIA 298 C Aviation Seminar	.5–12
AVIA 299 C Independent Study	.5–2

**AVIATION CERTIFICATE I —
PRIVATE PILOT Program Code: 1C22916**

This certificate provides students who have begun flying with the basic background and knowledge to gain entry-level employment in the Aviation Industry in areas such as line service and fueling. To earn a certificate, complete the required courses with a minimum grade of “C.” At least 50% of all course work must be completed at Cypress College.

Required courses are listed in suggested sequence:

	Units
AVIA 102 C Career Communication/Portfolio	3
AVIA 104 C Air Transportation	3
	or
ATC 270 C Airline Operations	(3)
AVIA 132 C Private Pilot	4
AVIA 140 C Meteorology	3
AVIA 144 C Aircraft and Engines	3
Total Units	16

**AVIATION CERTIFICATE II —
INSTRUMENT PILOT Program Code: 1C22917**

This certificate provides students with the necessary background to gain employment in the Aviation Industry requiring knowledge of weather, navigation and instrument flight such as flight scheduling and general aviation dispatching. To earn a certificate, complete the required courses with a minimum grade of “C.” At least 50% of all course work must be completed at Cypress College.

Required courses are listed in suggested sequence:

	Units
AVIA 102 C Career Communication/Portfolio	3
AVIA 104 C Air Transportation	3
	or
ATC 270 C Airline Operations	(3)
AVIA 132 C Private Pilot	4
AVIA 140 C Meteorology	3
AVIA 144 C Aircraft and Engines	3
AVIA 136 C Air Navigation	3
AVIA 196 C Ground Trainer Lab — Instrument Flight	1
AVIA 232 C Instrument Rating	3
Total Units	23

**AVIATION CERTIFICATE III —
COMMERCIAL PILOT** Program Code: 1C22918

This certificate prepares students for entry into the commercial pilot profession. To earn a certificate, complete the required courses with a minimum grade of “C.” At least 50% of all course work must be completed at Cypress College.

Required courses are listed in suggested sequence:		Units
AVIA 102 C	Career Communication/Portfolio	3
AVIA 104 C	Air Transportation	3
	or	
ATC 270 C	Airline Operations	(3)
AVIA 132 C	Private Pilot	4
AVIA 140 C	Meteorology	3
AVIA 144 C	Aircraft and Engines	3
AVIA 136 C	Air Navigation	3
AVIA 196 C	Ground Trainer Lab — Instrument Flight	1
AVIA 232 C	Instrument Rating	3
AVIA 240 C	Commercial Pilot Seminar	3
AVIA 244 C	Aviation Instructor	3
AVIA 256 C	Crew Resource Management	3
	Total Units	32

**AVIATION CERTIFICATE IV —
ADVANCED PILOT** Program Code: 1C22919

This certificate prepares students for entry into the aviation/air transportation industry as a professional pilot. To qualify for this certificate, students must have completed all of the required courses listed below and four (4) units from the list of electives. To earn a certificate, complete the required courses with a minimum grade of “C.” At least 50% of all course work must be completed at Cypress College.

Required courses are listed in suggested sequence:		Units
AVIA 102 C	Career Communication/Portfolio	3
AVIA 104 C	Air Transportation	3
	or	
ATC 270 C	Airline Operations	(3)
AVIA 132 C	Private Pilot	4
AVIA 136 C	Air Navigation	3
AVIA 140 C	Meteorology	3
AVIA 144 C	Aircraft and Engines	3
AVIA 196 C	Ground Trainer Lab — Instrument Flight	1
AVIA 232 C	Instrument Rating	3
AVIA 240 C	Commercial Pilot Seminar	3
AVIA 244 C	Aviation Instructor	3
AVIA 256 C	Crew Resource Management	3
	Elective Units	4
	Total Units Required	36

Electives: To complete all major course requirements, students must complete 4 elective units from the list below for a total of 36 units.

	Units	
AVIA 050 C	Special Projects — Aviation	2
AVIA 112 C	Airline/Aviation Management	3
AVIA 148 C	Air Traffic Control	3
AVIA 152 C	Glider Theory	3
AVIA 189 C	Flight Training Device — Intro	.5
AVIA 190 C	Flight Training — Private Pilot	2
AVIA 191 C	Flight Training — Instrument Rating	2
AVIA 192 C	Flight Training — Commercial Pilot	2
AVIA 193 C	Flight Training — Flight Instructor	1–5
AVIA 197 C	Ground Trainer Lab — Glass Cockpit	1
AVIA 250 C	Turbine Simulator Observation	.5
AVIA 255 C	Turbine Simulator Orientation	.5
AVIA 295 C	Aviation Internship	3
AVIA 298 C	Aviation Seminar	.5–12
AVIA 299 C	Independent Study	.5–2

**ARTICULATION AGREEMENTS ARE
IN EXISTENCE FOR TRANSFER PROGRAMS
TO THE FOLLOWING UNIVERSITIES:**

- Arizona State University
- California State University, Los Angeles
- San Jose State University
- Southern Illinois University

Students should consult a counselor or www.assist.org for lower division major requirements for most California public universities. (See the Standard Definitions section of the catalog for a description of ASSIST.) Students transferring to an independent college/university should consult the catalog of the individual school and a counselor for lower division major requirements.

Aviation (AVIA)

Through arrangements with the University of Southern California (USC) and Loyola Marymount University (LMU), three-, and four-year Air Force Reserve Officers Training Corps (AFROTC) programs are available to all qualified students at Cypress College. For additional information, visit www.afrotc.com.

Academic units earned in this program are counted as elective units toward fulfillment of graduation requirements. Successful completion of the AFROTC programs leads to a commission as an officer in the United States Air Force. Those students who qualify and desire to enter Air Force pilot training will be given flight instruction in either the two- or four-year program. Competitive scholarships are available to qualified students. All scholarship students receive tuition, laboratory and book fees, and \$350–\$500 a month. For additional information, contact the Department of Aerospace Studies (AFROTC) at Loyola Marymount at (310) 338-2770, or UCLA at (310) 825-1742 (www.afrotc.ucla.edu), or USC at (213) 740-2670.

**CERTIFICATED PILOTS —
CREDIT BY EXAMINATION**

The Commercial Pilot program at Cypress College is intended to prepare a student for employment in the aviation industry. Although the college offers only ground instruction and ground trainer instruction, it is recognized that flight training and pilot certificates are also required for employment.

In order to complete qualifications for employment, the student arranges for, and secures, the flight training necessary for the needed pilot certificates and ratings. Cypress College and the North Orange County Community College District assume no responsibility or liability for the flight training so obtained.

Unit credit (no grade) may be awarded through the Credit by Examination process (see index). Pilot certificates and ratings issued to the student by the Federal Aviation Administration will be used as evidence and certification of competency. A maximum of 12 units will be granted via Credit by Examination.

AVIA 050 C Special Projects — Aviation 2 Units

Term hours: 16–18 lecture and 48–54 laboratory TBA. This course includes individually directed research by independent study, dealing with present and future problems of the aviation/travel industry. The student will apply previously learned principles and procedures to practical problems to develop increased understanding and to demonstrate knowledge of the subject. May be taken for credit 4 times.

AVIA 100 C Introduction to Aviation 3 Units

Term hours: 48–54 lecture. This course is a general introductory course covering the development of aviation and its importance in the economy. Special emphasis is placed on the history of aviation, the airlines and general aviation. (CSU)

AVIA 102 C Career Communication/Portfolio 3 Units

Term hours: 48–54 lecture. Students will learn how professional presentation skills can make the difference in achieving their personal career success. This course reviews both oral and written communication skills including the development of a comprehensive resume, cover letter, business writing samples, interviewing skills, technology basics, business etiquette, and a career portfolio. Video will be used to help students achieve maximum effectiveness in mock-interviews. Students will also learn test-taking strategies necessary for career success. (CSU)

AVIA 103 C Aviation Open Lab .5 to 3 Units

Corequisite: Concurrent enrollment in at least one other Aviation course required.

Term hours: 24–162 laboratory depending on units attempted. This open-entry, open-exit course with flexible hours and variable units allows self-paced individualized instruction and/or practice in basic flight skills for aviation students. This course provides students with the equipment needed to complete aviation assignments; therefore, concurrent enrollment in any aviation class is required. Twenty-seven (27) hours are required for each one-half unit. May be taken for credit 4 times. Open Entry/Open Exit. Pass/No Pass only. \$5.00 Material Fee — Payable at Registration. (CSU)

AVIA 104 C Air Transportation 3 Units

Prerequisite: Completion of or concurrent enrollment in AVIA 100 C or AVIA 132 C.

Term hours: 48–54 lecture. This course presents the development and current status of the air transportation industry, including aircraft types, airport facilities, State and Federal regulations, security issues, economic challenges, career opportunities, and services of United States air carriers and the organization and function of the FAA, NTSB, IATA and ICAO. Pass/No Pass/Letter Grade Option. (CSU)

AVIA 112 C Airline/Aviation Management 3 Units

Term hours: 48–54 lecture. Students will study the application of management principles to the airlines and general aviation. Major areas of study include planning, organization, regulations, manpower management, facilities, marketing, administration, safety, security, and supervision strategies. (CSU)

AVIA 132 C Private Pilot 4 Units

Term hours: 48–54 lecture and 48–54 laboratory. This course is an introduction to basic principles of aviation, meteorology, navigation, radio communication and Federal Aviation Regulations to qualify the student for the FAA Knowledge examination for the Private Pilot Certificate and meets the FAA requirement for ground training. (CSU)

AVIA 136 C Air Navigation 3 Units

Prerequisite: Completion of or concurrent enrollment in AVIA 132 C.

Term hours: 48–54 lecture. This course is a study of pilotage, dead reckoning, and radio navigation techniques; solution and application of navigation problems. This course meets partial fulfillment of the requirements of the FAA for ground training. (CSU)

AVIA 140 C Meteorology 3 Units

Prerequisite: Completion of or concurrent enrollment in AVIA 132 C.

Term hours: 48–54 lecture. This is a course of study of weather recognition, icing, fog, fronts, clouds, weather maps and symbols, forecasting pressure patterns, wind systems, temperature-humidity-dew point relationships, precipitation, with emphasis on the practical application of this knowledge to safe flying practices. The services and assistance available from the U.S. Weather Bureau will be highlighted. The course meets the meteorology requirements of the FAA for ground training. (CSU)

AVIA 144 C Aircraft and Engines 3 Units

Prerequisite: Completion of or concurrent enrollment in AVIA 132 C.

Term hours: 48–54 lecture. This course is a study of the theory of flight, aircraft design, construction, operation limitations, repair and maintenance, maintenance records and aircraft accessories. Engine study includes principles of internal combustion engines, engine design and construction, fuel, lubrication and cooling systems, propellers, troubleshooting and preventive maintenance. This course meets partial fulfillment of the requirements of the FAA for ground training. (CSU)

AVIA 152 C Glider Pilot 3 Units

Term hours: 48–54 lecture. This is an introductory course in glider flying including the theory of flight, weather, Federal Aviation Regulations, as well as principles and techniques of cross-country and competition flying. It prepares students for the FAA Private Pilot-Glider knowledge examination. Pass/No Pass/Letter Grade Option. (CSU)

AVIA 189 C Flight Training Device — Introduction .5 Units

Term hours: 24–27 laboratory. Students will receive a hands-on introduction to a PC-based Flight Training Device and become familiar with the fundamentals of flight, flight terminology, flight controls, and instrument interpretations. May be taken for credit 4 times. Pass/No Pass/Letter Grade Option. (CSU)

AVIA 190 C Flight Training — Private Pilot 2 Units

Prerequisite: FAA Private Pilot Certificate and completion of at least 3 units of Aviation (132 or above) with a "C" or higher grade.

Term hours: Hours as required by FAA. Students who have earned the FAA Private Pilot Certificate may be granted college credit by meeting the above prerequisites and the Credit by Examination requirements as published in this catalog. Pass/No Pass/Letter Grade Option. (CSU)

AVIA 191 C Flight Training — Instrument Rating 2 Units

Prerequisite: FAA Pilot Certificate with Instrument Rating and completion of at least 3 units of AVIA (132 or above) with a "C" or higher grade.

Term hours: Hours as required by FAA. Students who have earned an FAA Instrument Rating on their Pilot Certificate may be granted college credit by meeting the above prerequisites and the Credit by Examination requirements as published in this catalog. Pass/No Pass/Letter Grade Option. (CSU)

AVIA 192 C Flight Training — Commercial Pilot 2 Units

Prerequisite: FAA Commercial Pilot Certificate and completion of at least 3 units of AVIA (132 or above) with a "C" or higher grade.

Term hours: Hours as required by the FAA. Students who have earned the FAA Commercial Pilot Certificate may be granted college credit by meeting the above prerequisites and meeting the current Credit by Examination requirements as published in this catalog. Pass/No Pass/Letter Grade Option. (CSU)

AVIA 193 C Flight Training — Flight Instructor 1 to 5 Units

Prerequisite: FAA Pilot Certificate with Instrument Rating and completion of at least 3 units of AVIA (132 or above) with a “C” or better.

Term hours: Hours as required by FAA. Students who have earned the FAA Flight Instructor Certificate may be granted college credit as follows: One unit of credit may be granted for each of the following Flight Instructor Certificates or Ratings: Airplane Single Engine, Airplane Multi-engine, Rotocraft, Glider and Instrument. Credit may be granted by meeting the above prerequisites and the Credit by Examination procedures as published in this catalog. May be taken for credit 4 times. Pass/No Pass/Letter Grade Option. (CSU)

AVIA 196 C Ground Trainer Laboratory — Instrument Flight 1 Unit

Prerequisite: Completion of, or concurrent enrollment in, AVIA 132 C or completion of FAA Private Pilot.

Term hours: 16–18 lecture and 16–18 laboratory. This course offers the student the opportunity to develop and maintain necessary instrument flight skills. Laboratory time will be divided between instrument ground trainer and multi-media aids. Flight time in the approved ground trainers may be applied toward requirements for both attaining and maintaining flight ratings. May be taken for credit 4 times. Pass/No Pass/Letter Grade Option. (CSU)

AVIA 197 C Ground Trainer Lab — Glass Cockpit 1 Unit

Prerequisite: Completion of or concurrent enrollment in AVIA 132 C with a minimum grade of “C.”

Term hours: 48–54 laboratory. This course offers students an introduction to the Technically Advanced Aircraft (TAA) Glass Cockpit. The Flight Training Device (FTD) will enable students to become familiar with the operation and displays of the GPS navigator, Primary Flight Display (PFD) and the Multifunction Display (MFD) featured in most current production aircraft. May be taken for credit 4 times. Pass/No Pass/Letter Grade Option. (CSU)

AVIA 220 C Advanced Air Navigation 2 Units

Prerequisite: Completion of, or concurrent enrollment in, AVIA 136 C Air Navigation.

Term hours: 32–36 lecture. This is a course stressing advanced navigation methods and principles including radio and electronic navigation aids, celestial navigation, computerized flight planning and cruise control. (CSU)

AVIA 232 C Instrument Rating 3 Units

Prerequisite: Completion of or concurrent enrollment in AVIA 132 C with a minimum grade of “C” or completion of FAA Private Pilot Certificate.

Advisory: AVIA 136 C and AVIA 240 C.

Term hours: 48–54 lecture. This course is designed to prepare or requalify in instrument flight procedures and techniques, including air traffic control, publications and regulations. This course reviews aeronautical ground training required to pass the FAA Instrument Pilot, Instrument Flight Instructor and Instrument Ground Instructor Knowledge Examinations. Flight time in a Flight Training Device is available by concurrent enrollment in AVIA 196 C. May be taken for credit 2 times. Credit by Examination (for first credit only). (CSU)

AVIA 236 C Aerodynamics 3 Units

Prerequisite: Sophomore standing in Aviation Program, eligibility for MATH 040 C and PHYS 130 C.

Term hours: 48–54 lecture. Students will learn the basic principles of aerodynamics, including airfoil shapes and characteristics, viscous effects, propellers, and aircraft performance viewed in terms of basic laws of physics, aircraft limitations and Federal Aviation Regulations. Emphasis will be on physical aspects of flight time. (CSU)

AVIA 240 C Commercial Pilot Seminar 3 Units

Prerequisite: AVIA 136 C, AVIA 140 C, or Pilot Certificate.

Term hours: 48–54 lecture. This course is a review of current Federal Aviation Regulations and Government Publications for the active pilot; aircraft loading and weight and balance; review of the aeronautical knowledge required to pass the FAA Commercial Pilot knowledge examination. This course meets partial fulfillment of the FAA requirements for ground training. AVIA 240 C may count toward the Aviation Major requirements the first time only. (Flight Training Device flight time is available by concurrent enrollment in AVIA 196 C). May be taken for credit 4 times. Pass/No Pass/Letter Grade Option. (CSU)

AVIA 244 C Aviation Instructor 3 Units

Prerequisite: AVIA 240 C Commercial Pilot Seminar and 120 hours of flight time.

Term hours: 40–45 lecture and 24–27 laboratory. This course is a study of principles of learning and teaching, elements of practical educational psychology, and a review of current trends and techniques in aviation instruction. Class participation in lesson preparation is included. This course meets partial fulfillment of the requirements of the FAA for ground instruction in preparation for the FAA Fundamentals of Instruction, Ground Instructor and Flight Instructor knowledge exams. (CSU)

AVIA 250 C Turbine Simulator Observation .5 Units

Term hours: 8–9 lecture. This course is an introduction and familiarization to an airliner’s flight deck. Students will become familiar with aerodynamics, the fundamentals of flight, the flight deck’s switches and controls, instrument interpretation, basic systems overview and duties of a flight officer. Time will be spent observing in a full-motion flight simulator used to train commercial airline pilots. A required 3-hour preparatory class will be held on campus and the remaining 6-hours will be delivered at FlightSafety International. Students will need to supply a picture ID and an approved background check before entrance to FlightSafety International. May be taken for credit 4 times. Fee may be required, subject to change by facility. (CSU)

AVIA 255 C Turbine Simulator Orientation .5 Units

Advisory: Completion of or concurrent enrollment in AVIA 250 C.

Term hours: 8–9 lecture. Students will practice the fundamentals of flight, utilizing the flight deck’s controls, instruments, and basic systems in a full-motion flight simulator. A required 3-hour preparatory class will be held on campus and the remaining 6-hours will be delivered at FlightSafety International. Students will need to supply a picture ID and an approved background check before entrance to FlightSafety International. May be taken for credit 4 times. Fee may be required, subject to change by facility. (CSU)

AVIA 256 C Crew Resource Management 3 Units

Term hours: 48–54 lecture. This course will examine the concepts of Crew Resource Management (CRM) and Human Factors and Aeronautical Decision Making currently practiced in commercial and corporate aviation. The role of crew supervision and training, leadership styles and management oversight will be studied. Single and multi-crew aircraft situations will be studied. Human factors research and aircraft accident investigations will be examined. Duplicate credit not granted for ATC 256 C. (CSU)

AVIA 295 C Aviation Internship 3 Units

Term hours: 16–18 lecture and 240–270 laboratory. This course offers practical work experience in an approved aviation related industry for the student(s) in the Aviation program. This course is designed to provide vocational learning opportunities throughout employment. Pass/No Pass/Letter Grade Option. (CSU)

AVIA 298 C Aviation Seminar**.5 to 12 Units***Prerequisite: May be required.**Corequisite: May be required.**Advisory: May be required.*

Variable Unit Class. May be taken for credit 1–4 times. Zero to twelve hours lecture and zero to thirty-six hours laboratory per week. This is a course for students who wish to increase their knowledge of Aviation. Various topics will be offered. Unit credit may range from .5 to 12 in any given semester. Consult the class schedule to verify credit for a particular semester. May be taken for credit 1–4 times. Pass/No Pass or Pass/No Pass/Letter Grade Option or Standard Letter Grade. Fees may be required — Payable at Registration. (CSU)

AVIA 299 C Independent Study**.5 to 2 Units***Prerequisite: Students will need to obtain an Approved Independent**Learning Contract from the supervising instructor.*

Term hours: 8–36 lecture depending on units attempted. This course is designed for those students who wish to increase their knowledge of the aviation industry through professionally directed independent study or research. Unit credit may range from .5 to two units in any given semester. May be taken for credit 4 times. Pass/No Pass/Letter Grade Option. (CSU)

Biology

Division of Science/Engineering/Mathematics

Division Dean — Richard Fee*Faculty*

Sujata Chiplunkar

David Gill

Joel Gober

Alex Mintzer

Fumio Ogoshi

Michelle Palmisano

Adel Rajab

Tony Sanchez

Dee Ann Sato

Stephanie Spooner

Counselor

Deidre Porter

PROGRAM LEARNING OUTCOMES (PLOs)

The courses taught by this department contribute to the General Education and Basic Skills Program Learning Outcomes. Please refer to General Education and Basic Skills Program Learning Outcomes.

BIOLOGICAL SCIENCES TRANSFER PROGRAM

Students should consult a counselor or www.assist.org for lower division major requirements for most California public universities. (See the Standard Definitions section of the catalog for a description of ASSIST.) Students transferring to an independent college/university should consult the catalog of the individual school and a counselor for lower division major requirements.

Biology (BIOL)

BIOL 101 C General Biology — Lecture/Lab**5 Units***Advisory: High school chemistry or CHEM 101 C or CHEM 107 C are recommended.*

Term hours: 64–72 lecture and 48–54 laboratory. The course is a survey of modern biological concepts from the areas of molecular, cellular, organismic, and population biology, stressing evolution as the central theme of modern biology. The study of the flow of energy through biological systems is emphasized. This is a general education course in the biological science area. This course will satisfy the Biological Sciences portion of the state college and university general education requirement. Duplicate credit not granted for BIOL 101HC. No Credit if taken after BIOL 174 C, BIOL 176 C or BIOL 177 C. Pass/No Pass/Letter Grade Option. (UC Credit Limitation/CSU, AA GE, CSU GE, IGETC)

BIOL 101HC Honors General Biology**5 Units***Advisory: High school chemistry or CHEM 101 C or CHEM 107 C are recommended.*

Term hours: 64–72 lecture and 48–54 laboratory. The course is an enhanced survey of modern biological concepts for Honors students. The emphasis of this course is on contemporary readings of relevant biology literature. Written essays pertaining to current issues in biology will be paramount. The class will be conducted as a seminar and will require a significant research project that uses correct documentation skills. The course will develop increased critical thinking, reading and writing skills. BIOL 101HC will satisfy the Geological Sciences portion of the state college and university general education requirement. Duplicate credit not granted for BIOL 101 C. No Credit if taken after BIOL 174 C, BIOL 176 C or BIOL 177 C. (UC Credit Limitation/CSU, AA GE, CSU GE, IGETC)

BIOL 102 C Human Biology**3 Units**

Term hours: 48–54 hours lecture. The course is a study of modern biological concepts presented in a human context. The concepts will include human evolution, anatomy, physiology, genetics, population biology, and ecological principles. Included in the course will be discussion on current topics on environmental and public health issues as they relate to the human condition. Not open to students with credit in BIOL 101 C or BIOL 101HC. Pass/No Pass/Letter Grade Option. (UC/CSU, AA GE, CSU GE, IGETC)

BIOL 103 C Environmental Science**3 Units**

Term hours: 48–54 lecture. The course is a study of the ecological principles which form the basis for understanding human existence in relation to environment quality. The topics include human, biological, and cultural evolution; ecological principles; human population issues; and problems relating to the development and use of energy and other resources. In addition, the causes and consequences of pollution will be addressed. The development of an earth ethic toward the world will be stressed. Pass/No Pass/Letter Grade Option. (UC/CSU, AA GE, CSU GE, IGETC)

BIOL 107 C Nutrition and World Food Issues**3 Units**

Term hours: 48–54 lecture. This course is a study of the biological basis of human nutrition, including a survey of anatomical and physiological principles. A study of the human diet in the context of disease prevention, world food supply, and ecological factors will also be included. Pass/No Pass/Letter Grade Option. (UC/CSU, AA GE)

Cypress College Biology Majors Course Sequence*

Courses

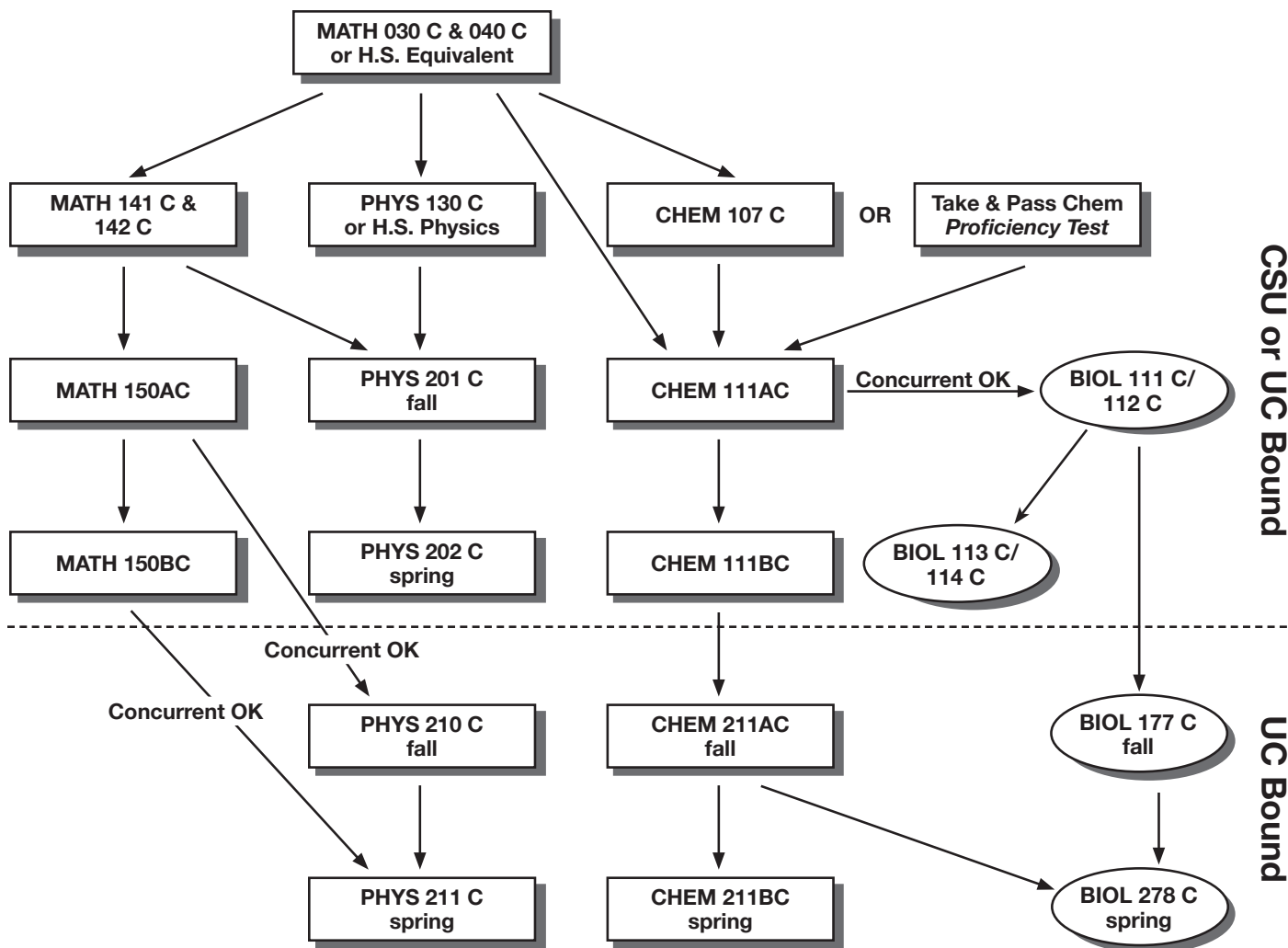

*Each UC and CSU university has specific transfer requirements. Please consult with your counselor and www.assist.org for campus-specific requirements.

Contact: Dr. Adel Rajab at arajab@CypressCollege.edu or (714) 484-7000 x48629

BIOL 111 C Principles of Biology 1

3 Units

Prerequisite: Completion of or concurrent enrollment in CHEM 111AC.

Advisory: ENGL 060 C.

Term hours: 48–54 lecture. This is the first course in a two-semester lecture sequence for science majors. This course presents the biochemistry and molecular biology of cells. In addition, cell principle, cell structure and function, cell growth and reproduction, the development of animals, and Mendelian and molecular genetics will be presented. This course will meet the preparation needs of students transferring to upper division biology study. (UC Credit Limitation/CSU, AA GE, CSU GE, IGETC)

BIOL 112 C Principles of Biology 1 Lab

2 Units

Prerequisite: Completion of or concurrent enrollment in BIOL 111 C.

Term hours: 96–108 laboratory. This is a laboratory course that complements BIOL 111 C. The course explores modern experimental molecular, biochemical, and cellular biology techniques. This course may be taken concurrently with or subsequently to BIOL 111 C. Both BIOL 111 C and BIOL 112 C are required for the biology major. (UC Credit Limitation/CSU, AA GE, CSU GE, IGETC)

BIOL 113 C Principles of Biology 2**3 Units**

Prerequisite: Completion of BIOL 111 C or equivalent course with a "C" or better.

Advisory: MATH 040 C or Algebra II.

Term hours: 48–54 lecture. This is the second course in a two-semester lecture sequence for biology majors. This course is designed to familiarize students with the diversity, evolution, physiology, and ecology of living organisms. Population genetics will also be presented. This class is designed for science majors in transfer programs to upper-division study of biology. (UC Credit Limitation/CSU, AA GE, CSU GE, IGETC)

BIOL 114 C Principles of Biology 2 Lab**2 Units**

Prerequisite: Completion of or concurrent enrollment in BIOL 113 C or equivalent course with a "C" or better.

Advisory: MATH 040 C or Algebra II.

Term hours: 96–108 laboratory. This is a biology laboratory course that complements BIOL 113 C in a two-semester sequence for science majors. This course is designed to familiarize students with the diversity, evolution, physiology, and ecology of living organisms. Population genetics will also be presented. Concurrent enrollment in BIOL 113 C recommended. (UC Credit Limitation/CSU, AA GE, CSU GE, IGETC)

BIOL 122 C Marine Biology**5 Units**

Term hours: 64–72 lecture and 48–54 laboratory. This is a survey of the natural history and biology of marine organisms, and includes an introduction to physical and chemical oceanography, marine ecology, and energy flow within the marine environment, as well as some basic biological concepts using live ecosystems as examples. Pollution and conservation of the marine environment will also be considered. The course satisfies the biological science with a laboratory transfer requirement of universities and state colleges. A single optional boat field trip may be scheduled with a charter cost not to exceed \$30.00. Pass/No Pass/Letter Grade Option. (UC/CSU, AA GE, CSU GE, IGETC)

BIOL 125 C Island Biology**2 Units**

Advisory: BIOL 122 C.

Term hours: 24–27 lecture and 32–36 laboratory. This course is designed as an introduction to the nature and diversity of island life. It offers the student an opportunity to study marine communities with an emphasis on community interactions. The course will also include a consideration of marine wilderness and conservation problems as well as biological processes as they occur on islands. One or more weekend field trips for snorkeling, free diving and field study will be an integral part of the course. A boat charter fee not to exceed \$50 may be required for field trips to the islands. Pass/No Pass/Letter Grade Option. (CSU)

BIOL 160 C Integrated Medical Science**3 Units**

Term hours: 48–54 lecture. This is a one-semester course that includes a systematic coverage of fundamental physical/chemical principles, basic biological concepts, and fundamentals of anatomy and physiology. The course is designed for various allied health programs (psychiatric technician, mortuary science, court reporting, etc.) or others who desire a background in human biology. Pass/No Pass/Letter Grade Option. (CSU, AA GE)

BIOL 161 C Integrated Medical Science Lab**1 Unit**

Prerequisite: Completion of or concurrent enrollment in BIOL 160 C.

Term hours: 48–54 laboratory. The course is a one-semester laboratory that offers the student exposure to the basic principles discussed in BIOL 160 C. The course is designed primarily for allied health vocational programs that require a laboratory course, but is open to other interested students. Pass/No Pass/Letter Grade Option. (CSU)

BIOL 174 C Cell and Molecular Biology**5 Units**

Prerequisite: Completion of or concurrent enrollment in CHEM 111AC with a minimum grade of "C."

Advisory: ENGL 060 C.

Term hours: 56–63 lecture and 96–108 laboratory. This is the first course within the biology majors AS degree. This course presents the biochemistry and molecular biology of cells and tissues. Representative topics to be included are: biomolecules, cell structure and metabolism, cell growth and reproduction, cell integration into tissues, and basic Mendelian and molecular genetics. This course will meet the preparation needs of students transferring to upper division biology study. Cost of field trips not to exceed \$30.00 (UC Credit Limitation/CSU, AA GE, CSU GE, IGETC)

BIOL 175 C Evolution and Biodiversity**5 Units**

Prerequisite: BIOL 174 C with a minimum grade of "C" or completion of BIOL 111 C or equivalent course with a grade of "C" or better.

Term hours: 56–63 lecture and 96–108 laboratory. This is the second course in a three-semester lecture/lab sequence for science majors and the Biology AS degree. This course is designed to familiarize students with the evolution and diversity of living organisms. Population genetics and basic concepts of anatomy related to diversity of form will also be presented. This class is designed for science majors in transfer programs to upper-division study of biology. Cost of field trips not to exceed \$30.00. (UC Credit Limitation/CSU, AA GE, CSU GE, IGETC)

BIOL 180 C Field Biology**5 Units**

Term hours: 64–72 lecture and 48–54 laboratory. This course includes reading and discussions in the biology of selected natural areas and may include driving, camping, hiking, or other activity to study the natural history of a particular biotic region. Extensive multi-day field trips will be required. Pass/No Pass/Letter Grade Option. (CSU)

BIOL 210 C Anatomy and Physiology**5 Units**

Advisory: BIOL 160 C, or one semester each of college biology/chemistry, or one year each of high school biology/chemistry completed within the last five years.

Term hours: 48–54 lecture and 96–108 laboratory. The course includes a study of the normal structure and function of the human body using mammalian specimens as examples. Selected physiological exercises are included which often utilize the student's own body function. This course is designed for students pursuing the health professions (registered nursing, radiological technology, medical records technology, dental hygiene, respiratory therapy, etc.), physical education majors, and any other interested students. (Not open to students with credit in BIOL 240 C.) Pass/No Pass/Letter Grade Option. (UC/CSU, AA GE, CSU GE, IGETC)

BIOL 220 C Medical Microbiology**4 Units**

Advisory: BIOL 160 C or one year each of high school chemistry/biology completed in the last five years with a minimum grade of "C" or one semester each college chemistry/biology completed in the last five years with a minimum grade of "C."

Term hours: 48–54 lecture and 48–54 laboratory. This course is a study of the etiology, transmission, diagnosis, pathology, and control of infectious disease. Special attention is given to the topics of immunology and chemotherapy. Laboratory emphasis is placed on providing experience and insight into the processes of specimen handling, isolation, identification, and sensitivity testing of pathogenic microorganisms. Aseptic techniques are stressed throughout the course. This course is recommended for students of nursing (RN), dental technology, medical records, and baccalaureate degree medical or public health programs. Recommended background is one year each, high school chemistry/biology, or one semester each, college chemistry/biology. If the student has no science background, prior completion of BIOL 160 C is strongly recommended. Pass/No Pass/Letter Grade Option. (CSU)

BIOL 231 C General Human Anatomy 4 Units*Advisory: High School Biology and Chemistry.*

Term hours: 48–54 lecture and 48–54 laboratory. This course presents a logical analysis of body tissues, organs, and systems. It stresses the microscopic, developmental, and gross anatomy of mammals, with special emphasis on human anatomy. Special attention is given to pathological as well as normal conditions. The three hour laboratory includes study of fresh and preserved specimens and models. This course is designed primarily for physical education and allied health majors. High school biology and chemistry, or equivalent is recommended background. Students are encouraged to take BIOL 101 C and BIOL 160 C if they have no previous science background. Pass/No Pass/Letter Grade Option. (UC/CSU, AA GE, CSU GE, IGETC)

BIOL 241 C General Human Physiology 4 Units*Prerequisite: BIOL 230 C or BIOL 231 C or BIOL 210 C.**Advisory: CHEM 101 C.*

Term hours: 48–54 lecture and 48–54 laboratory. This course is an in-depth study of human function. Special attention is given to the abnormal as well as the normal functional state. The laboratory experience includes selected exercises that emphasize the interrelationships between structure and function. It is designed primarily for physical education and allied health programs that require 3 hours of laboratory per week. Pass/No Pass/Letter Grade Option. (UC/CSU, CSU GE, AA GE, IGETC)

BIOL 276 C Ecology and Physiology 5 Units*Prerequisite: BIOL 175 C with a minimum grade of "B."*

Term hours: 56–63 lecture and 96–108 laboratory. This is the third course within the Biology majors AS degree. This course examines the basic principles governing interactions between organisms and the environment and the physiological responses of organisms to external and internal stimuli. Intended for biology majors, this lecture/lab course emphasizes ecological principles and relationships among organisms and between organisms and their environments. The course also emphasizes the physiology of plant and animal systems. Cost of field trips not to exceed \$30.00. (UC/CSU)

BIOL 277 C Genetics 3 Units*Prerequisite: BIOL 111 C or BIOL 174 C.*

Term hours: 48–54 lecture. This course presents an introduction to genetics, inheritance and genetic changes that occur over time in populations. Basic features of the replication and expression of DNA, cell division and gene transmission are considered. Recombination and mutation in diploid organisms are discussed. Concepts of genetic variability and the role of natural selection in the evolution of populations are presented. Cost of field trips not to exceed \$30.00. (UC/CSU)

BIOL 278 C Molecular Biology 4 Units*Prerequisite: BIOL 177 C and CHEM 211AC.*

Term hours: 64–72 lecture. This course presents mechanisms of gene expression and its regulation at the transcriptional and translational levels in eukaryotic and prokaryotic systems. The structure and biosynthesis of proteins and nucleic acids, as well as the importance of viral life cycles in understanding basic cellular processes, will be included. The major biochemical pathways in cells, with an emphasis on the thermodynamic constraints on living systems, will also be studied. (UC/CSU)

BIOL 298 C Biology Seminar .5 to 12 Units*Prerequisite: May be required.**Corequisite: May be required.**Advisory: May be required.*

Term hours: 0–216 lecture and/or 0–648 laboratory depending on units attempted. This seminar is designed to intensify knowledge in a variety of biological topics. They may include lectures, discussions, field excursions, and other activities at the discretion of the instructor. Actual seminar topics will be listed in the class schedule for a particular semester. May be taken for credit 1–4 times. May be taken for credit 1–4 times. Pass/No Pass or Pass/No Pass/Letter Grade Option or Standard Letter Grade. Fees may be required — Payable at Registration. (UC Credit Limitation/CSU)

BIOL 299 C Independent Study for Biology .5 to 2 Units*Prerequisite: Approved Independent Study Learning Contract.*

Term hours: 0–36 lecture and 0–108 laboratory depending on units attempted. This is for biology majors who have demonstrated interest in and capability for increased knowledge of biological and medical sciences through individual study, small group discussion/conference, special laboratory projects, or field research projects. May be taken for Credit 4 times. Pass/No Pass/Letter Grade Option. (UC Credit Limitation/CSU)

Business —**See Accounting (ACCT), or Management (MGT), or Marketing (MKT)****Business Administration****ASSOCIATE IN SCIENCE DEGREE IN BUSINESS ADMINISTRATION FOR TRANSFER**

This curriculum is designed to provide an opportunity for the Business Administration major to achieve an Associate in Arts in Business Administration for Transfer Degree (AA-T in Business Administration) which completes the first and second year requirements for transfer into the CSU system.

Advanced degrees and/or professional certificates, such as a baccalaureate degree, are required for those considering professional careers. Completion of this curriculum will demonstrate a commitment to the field and provide comprehensive preparation for further academic study through upper-division course work. This curriculum specifically prepares the prospective transfer student for upper division coursework in Business Administration or a similar major at a California State University (CSU) campus. Students should consult a counselor, the Transfer Center and the catalog of the transfer college or university to plan a specific program of study to meet the college or university's requirements. Note: Courses that fulfill major requirements for an Associate Degree for Transfer at Cypress College might not be the same as those required for completing the major at all transfer institutions offering a Baccalaureate Degree.

The Student Transfer Achievement Reform Act (Senate Bill 1440, now codified in California Education Code sections 66746–66749) guarantees admission to a California State University (CSU) campus for any community college student who completes an “associate degree for transfer,” a newly established variation of the associate degrees traditionally offered at a California community college. The AA-T is intended for students who plan to complete a bachelor’s degree in a similar major at a CSU campus. Students completing these degrees (AA-T) are guaranteed admission to the CSU system, but not to a particular campus or major. Students transferring to a CSU campus that does accept the AA-T will be required to complete no more than 60 units after transfer to earn a bachelor’s degree (unless the major is designated “high-unit” major). This degree may not be the best option for students intending to transfer to a particular CSU campus or to a university or college that is not part of the CSU system. Students should consult with a counselor when planning to complete the degree for more information on university admission and transfer requirements.

Students successfully completing the AA-T in Business Administration will gain knowledge in accounting, business communications, information technologies, finance, law, management, and marketing. Because business is such a broad field with many emphases and majors, this degree will provide the student a broad overview of the possible fields of study in various business areas.

To earn an AA-T in Business Administration students must complete the following requirements: (1) a minimum of 27 semester units or 40.5 quarter units in the Business Administration major with a minimum grade of “C”; (2) California State University General Education Breadth requirements (CSU GE Breadth) or the Intersegmental General Education Transfer Curriculum (IGETC); (3) elective courses to complete a minimum of 60 units of CSU transferable coursework; (4) have an overall GPA of 2.0.

Required Core Courses are listed in suggested sequence. (17 units)

	Units
ACCT 101 C Financial Accounting	4
ACCT 102 C Managerial Accounting	4
ECON 100 C Principles of Economics — Macro	3
or	
ECON 100HC Honors Principles of Economics	(3)
ECON 105 C Principles of Economics — Micro	3
or	
ECON 105HC Honors Principles of Economics	(3)
MGT 240 C Legal Environment of Business	3

List A: Select one of the following: (4 units)

	Units
MATH 130 C Survey of Calculus	4
MATH 120 C Intro Probability and Statistics	4
MATH 115 C Finite Mathematics	4

List B: Select two of the following or any course from List A not already chosen. (6–8 units)

	Units
CIS 111 C Computer Information Systems	3
MGT 161 C Introduction to Business	3
or	
MGT 211 C Writing for Business	(3)
Total Units	27–29

**ASSOCIATE IN ARTS DEGREE
BUSINESS**

Program Code: 1A16599

This curriculum is designed to provide an opportunity for the business major to achieve an Associate in Arts Degree Business while completing the first and second year requirements for transfer to a four-year institution. While a baccalaureate degree is recommended preparation for those considering professional careers in business, completion of this curriculum will demonstrate commitment to the field and provide comprehensive preparation for upper-division work. Students should consult a counselor and the catalog of the individual college or university to plan a program of study. The internet site www.assist.org will also provide information for California public universities. Courses selected to fulfill the requirements of the associate degree should reflect requirements of the college to which the student plans to transfer. To earn an Associate Degree students must complete: (1) all major course requirements with a minimum grade of “C”; (2) California State University General Education Breadth requirements (CSU GE Breadth) or IGETC General Education Plan; (3) any elective courses to complete a minimum of 60 units; (4) complete all graduation requirements; and, (5) have an overall GPA of 2.0. At least 50% of all major course work must be completed at Cypress College. Students pursuing more than one specified departmental major may double count a maximum of 7 units to fulfill major requirements. Courses that fulfill major requirements for an Associate Degree at Cypress College might not be the same as those required for completing the major at a transfer institution offering a Baccalaureate Degree. For information on specific university requirements, please consult with your counselor, or visit the Transfer Center.

Required courses are listed in suggested sequence:

	Units
MGT 161 C Introduction to Business	3
CIS 111 C Computer Information Systems	3
ECON 100 C Principles of Economics — Macro	3
or	
ECON 100HC Honors Principles of Economics	(3)
ECON 105 C Principles of Economics — Micro	3
or	
ECON 105HC Honors Principles of Economics	(3)
MGT 240 C Legal Environment of Business	3
or	
MGT 241 C Legal Aspects — Business Transactions	(3)
ACCT 101 C Financial Accounting	4
ACCT 102 C Managerial Accounting	4
MATH 130 C Survey of Calculus	4
MKT 222 C Principles of Marketing	3

Elective

	Units
MGT 211 C Writing for Business	3
Total Units	33

BUSINESS ADMINISTRATION TRANSFER PROGRAM

Accounting, Finance, International Business, Marketing, Management, Management — Information Systems, Quantitative Systems

Students should consult a counselor or www.assist.org for lower division major requirements for most California public universities. (See the Standard Definitions section of the catalog for a description of ASSIST.) Students transferring to an independent college/university should consult the catalog of the individual school and a counselor for lower division major requirements.

GENERAL BUSINESS TRANSFER PROGRAM

Accounting, Information Technologies, Finance, Law, Management, and Marketing

Students should consult a counselor or www.assist.org for lower division major requirements for most California public universities. (See the Standard Definitions section of the catalog for a description of ASSIST.) Students transferring to an independent college/university should consult the catalog of the individual school and a counselor for lower division major requirements.

Business Law — See Management (MGT)

Chemistry

Division of Science/Engineering/Mathematics

Division Dean — Richard Fee

Faculty

Robin De Roo
Allison Gotoh
Lenore Landis
Craig Tomooka

Counselor

Deidre Porter

PROGRAM LEARNING OUTCOMES (PLOs)

The courses taught by this department contribute to the General Education and Basic Skills Program Learning Outcomes. Please refer to General Education and Basic Skills Program Learning Outcomes.

CHEMISTRY TRANSFER PROGRAM

Students should consult a counselor or www.assist.org for lower division major requirements for most California public universities. (See the Standard Definitions section of the catalog for a description of ASSIST.) Students transferring to an independent college/university should consult the catalog of the individual school and a counselor for lower division major requirements.

Chemistry (CHEM)

CHEM 060 C Chemistry Review**1 Unit**

Term hours: 16–18 lecture. This course is a review of the concepts and principles of general, inorganic, and organic chemistry, as taught in: Introduction to Chemistry (CHEM 101 C), Fundamentals of College Chemistry (CHEM 107 C), General Chemistry I (CHEM 111AC) and/or General Chemistry II (CHEM 111BC). It is recommended for students who have completed or are currently enrolled in one of the previously named courses. May be taken for credit 4 times. Pass/No Pass only.

CHEM 100 C Chemistry for Daily Life**4 Units**

Term hours: 48–54 lecture and 48–54 laboratory. The course is designed for the non-science major seeking a laboratory science. The course will adopt a non-mathematical approach to explain the fundamental concepts of chemistry. From this foundation, the course will focus on topics that are related to the impact that chemistry has on our society. The laboratory section will provide hands-on experience with many of the lecture topics. (UC Credit Limitation/CSU, AA GE, CSU GE, IGETC)

CHEM 101 C Introduction to Chemistry**5 Units**

Prerequisite: MATH 020 C with a minimum grade of "C."

Term hours: 64–72 lecture and 32–36 discussion and 32–36 laboratory. This course is the first semester of a two-semester sequence (CHEM 101 C and CHEM 201 C). This course covers the basic principles of atomic structure, chemical bonding, the mole concept, states of matter, solutions, energy, and organic compounds. This course is designed for students majoring in health science. No credit if taken after CHEM 111AC. (UC Credit Limitation/CSU, AA GE, CSU GE, IGETC)

CHEM 103 C Chemistry in a Changing World**3 Units**

Term hours: 48–54 lecture. This is a general education course in chemistry. A non-mathematical approach will be taken to examine the fundamental concepts of chemistry and their application to various facets of life. Topics will include a discussion of chemicals in air, water, food, drugs, and the environment, as well as areas of current interest. Pass/No Pass/Letter Grade Option. (UC Credit Limitation/CSU, AA GE, CSU GE, IGETC)

CHEM 104 C Physical Science for Teachers**4 Units**

Prerequisite: MATH 020 C with a minimum grade of "C."

Term hours: 48–54 lecture and 48–54 laboratory. This activity-based course provides an introduction to the basic concepts of physical science with emphasis on their practical importance and application in the real world. Topics include global warming, the automobile, health, and energy. This course is intended for students who want to become primary school teachers. Duplicate credit not granted for PHSC 104 C. (CSU, AA GE, CSU GE)

CHEM 107 C Foundations of College Chemistry**5 Units**

Prerequisite: MATH 040 C with a minimum grade of "C."

Term hours: 64–72 lecture and 32–36 discussion and 32–36 laboratory. This course provides a general introduction to the basic concepts, principles and laws of modern chemistry. Topics include a study of atomic theory, molecular structure, chemical reactivity, and the properties of the various phases of matter. Laboratory experiments include both qualitative and quantitative analysis, with an emphasis on proper laboratory techniques. This course applies to the physical science requirement for general education and is not acceptable for credit for students majoring in physical science. CHEM 107 C is a recommended preparatory course for students planning to take CHEM 111AC and CHEM 111BC. No credit if taken after CHEM 111AC. (UC Credit Limitation/CSU, AA GE, CSU GE, IGETC)

CHEM 111AC General Chemistry I **5 Units**

Prerequisite: MATH 040 C and CHEM 107 C with a grade of "C" or better, or a passing score on the Chemistry Proficiency Test.

Term hours: 48–54 lecture and 32–36 discussion and 64–72 laboratory. Topics covered include the general principles of chemistry with associated laboratory analysis. This includes atomic structure, bonding, the mole concept, properties of solutions, gas laws, and thermochemistry. (UC/CSU, AA GE, CSU GE, IGETC)

CHEM 111BC General Chemistry II **5 Units**

Prerequisite: Completion of CHEM 111AC with a minimum grade of "C."

Term hours: 48–54 lecture and 32–36 discussion and 64–72 laboratory. Topics covered include the general principles of chemistry with associated laboratory analysis. This includes kinetics, equilibrium, thermodynamics, electrochemistry and nuclear chemistry. (UC Credit Limitation/CSU, AA GE, CSU GE, IGETC)

CHEM 112 C Chemistry for Engineers **3 Units**

Prerequisite: Completion of CHEM 111AC with a grade of "C" or better.

Term hours: 48–54 lecture. Topics covered include the general principles of chemistry. This includes kinetics, equilibrium, thermodynamics, electrochemistry and nuclear chemistry. (UC Credit Limitation/CSU)

CHEM 201 C Basic Organic and Biochemistry **5 Units**

Prerequisite: CHEM 101 C.

Term hours: 64–72 lecture and 32–36 discussion and 32–36 laboratory. This course is the second semester of a two-semester sequence (CHEM 101 C and CHEM 201 C). This course covers the structures, nomenclature, reactions, and applications of organic and biochemical compounds, as well as cell structure, metabolism, biotechnology, vitamins and enzymes. This course is designed for students majoring in health science. No credit if taken after CHEM 211AC. (CSU)

CHEM 205 C Analytical Chemistry **4 Units**

Prerequisite: CHEM 111BC or CHEM 112 C.

Term hours: 32–36 lecture and 96–108 laboratory. This is an introduction to analytical methods of chemical analysis. It includes gravimetric and volumetric methods for qualitative and quantitative determination of chemical compounds. Laboratory work emphasizes the use of modern chemical instrumentation methods and the tools for spectroscopic analysis, chromatography, potentiometric titration, NMR, electrochemical analysis, and mass spectroscopy. (UC/CSU)

CHEM 211AC Organic Chemistry I **5 Units**

Prerequisite: Completion of CHEM 111BC with a grade of "C" or better.

Term hours: 48–54 lecture and 32–36 discussion and 64–72 laboratory. This course is the first part of a two semester organic chemistry lecture and laboratory sequence. This course covers the study of functionalized compounds, stereochemistry, substitution and elimination reactions, alkenes, alkynes, and spectroscopic methods. Laboratory work includes the synthesis, isolation, and characterization of organic compounds by using modern techniques and instrumentation. This course is designed for students who plan to major in chemistry, biochemistry, biology, and premedical/prepharmacy/pre dental programs. (UC/CSU)

CHEM 211BC Organic Chemistry II **5 Units**

Prerequisite: Completion of CHEM 211AC with a grade of "C" or better.

Term hours: 48–54 lecture and 32–36 discussion and 64–72 laboratory. This course is the second part of a two semester organic chemistry lecture and laboratory sequence. The course includes the study of radicals, aromatic compounds, carbonyl-containing compounds, amines, biologically important compounds, and strategy in organic synthesis. Laboratory work includes modern techniques required to synthesize organic compounds, and the isolation and analysis of these compounds. This course is designed primarily for students who plan to major in chemistry, biochemistry, biology, and premedical/prepharmacy/pre dental programs. (UC/CSU)

CHEM 298 C Chemistry Seminar **.5 to 12 Units**

Prerequisite: May be required.

Corequisite: May be required.

Advisory: May be required.

Term hours: 0–216 lecture and 0–864 laboratory depending on units attempted. Seminars are designed to help students conceptualize and intensify knowledge in a variety of chemical topics. They may include lecture, discussions, and other activities at the discretion of the instructor. Actual seminar topics will be listed in the class schedule for a particular semester. Consult the class schedule to verify unit credit and prerequisites for a particular semester. May be taken for credit 1–4 times. Pass/No Pass or Pass/No Pass/Letter Grade Option or Standard Letter Grade. Fees may be required — Payable at Registration. (UC Credit Limitation/CSU)

Chinese

Division of Language Arts

Division Dean — Eldon Young

Faculty

Hong Chi

Counselors

Velia Lawson

Therese Mosqueda-Ponce

Daniel Pelletier

PROGRAM LEARNING OUTCOMES (PLOs)

The courses taught by this department contribute to the General Education and Basic Skills Program Learning Outcomes. Please refer to General Education and Basic Skills Program Learning Outcomes.

Chinese (CHIN)

CHIN 098 C Chinese Seminar **.5 to 12 Units**

Prerequisite: May be required.

Corequisite: May be required.

Advisory: May be required.

Term hours: 0–216 lecture and 0–432 laboratory depending on units attempted. This seminar is for students who wish to extend their knowledge of literature, language and culture through small group discussion. May be taken for credit 1–4 times. Pass/No Pass or Pass/No Pass/Letter Grade Option or Standard Letter Grade. Fees may be required — Payable at Registration.

CHIN 100 C Beginning Spoken Chinese 3 Units

Term hours: 48–54 lecture. This course is for students at beginning levels who would like to have exposure to Chinese without having to learn Chinese characters. It is an introduction to spoken Chinese with emphasis on pronunciation, oral practice, vocabulary development, and use of common expressions for daily conversations in a culturally appropriate way. May be taken for credit 2 times. Pass/No Pass/Letter Grade Option. (CSU, AA GE)

CHIN 101 C Elementary Chinese — Mandarin I 5 Units

Term hours: 80–90 lecture. The course emphasizes the acquisition of basic skills in pronunciation, listening, speaking, reading, and writing, and the grammar and vocabulary necessary to acquire these skills. Students will be introduced to customs, culture, and geography of China through lectures, films, and reading assignments. Pass/No Pass/Letter Grade Option. (UC/CSU, AA GE, CSU GE)

CHIN 102 C Elementary Chinese — Mandarin II 5 Units

Prerequisite: CHIN 101 C with grade of “C” or better or one year of high school Chinese with grade of “C” or better.

Term hours: 80–90 lecture. This course continues to emphasize the acquisition of basic skills in pronunciation, listening and speaking, reading, and writing, and the grammar and vocabulary necessary to acquire these skills. Students will increase their knowledge of the customs, culture, and geography of China and other Chinese speaking countries/areas through lectures, reading, writing assignments, and film. Pass/No Pass/Letter Grade Option. (UC/CSU, AA GE, CSU GE, IGETC)

CHIN 298 C Chinese Seminar .5 to 12 Units

Prerequisite: May be required.

Corequisite: May be required.

Advisory: May be required.

Term hours: 0–216 lecture and 0–432 laboratory depending on units attempted. This seminar is for students who wish to extend their knowledge of literature, language and culture through small group discussion. Fees may be required — Payable at Registration. May be taken for credit 1–4 times. Pass/No Pass or Pass/No Pass/Letter Grade Option or Standard Letter Grade. (UC Credit Limitation/CSU)

CHIN 298AC Seminar: Beginning Spoken Chinese 3 Units

Term hours: 48–54 lecture and 16–18 laboratory. This course is for students at beginning levels who would like to have exposure to Chinese without having to learn Chinese characters. It is an introduction to spoken Chinese with emphasis on pronunciation, oral practice, vocabulary development and use of common expressions for daily conversations in a culturally appropriate way. May be taken for credit 2 times. Credit/No Credit/Letter Grade Option. (CSU)

CHINESE TRANSFER PROGRAM

Students should consult a counselor or www.assist.org for lower division major requirements for most California public universities. (See the Standard Definitions section of the catalog for a description of ASSIST.) Students transferring to an independent college/university should consult the catalog of the individual school and a counselor for lower division major requirements.

**Communications —
See Journalism (JOUR)**

Communication Studies (formerly Speech)

Division of Language Arts

Division Dean — Eldon Young

Faculty

Michael Brydges

Patricia Ganer

Liana Koepfel

John Lambros

Counselors

Velia Lawson

Therese Mosqueda-Ponce

Daniel Pelletier

PROGRAM LEARNING OUTCOMES (PLOs)

The courses taught by this department contribute to the General Education and Basic Skills Program Learning Outcomes. Please refer to General Education and Basic Skills Program Learning Outcomes.

**ASSOCIATE IN ARTS IN
COMMUNICATION STUDIES FOR
TRANSFER DEGREE Program Code: 1S31002**

This curriculum is designed to provide an opportunity for the Communication Studies major to achieve an Associate in Arts Degree in Communication Studies for Transfer while completing the first and second year requirements for transfer to a four-year institution. While a baccalaureate degree is recommended preparation for those considering professional careers, completion of this curriculum will demonstrate commitment to the field and provide comprehensive preparation for upper division work.

The Student Transfer Achievement Reform Act (Senate Bill 1440, now codified in California Education Code sections 66746–66749) guarantees admission to a California State University (CSU) campus for any community college student who completes an “associate degree for transfer,” a newly established variation of the associate degrees traditionally offered at a California community college. The Associate in Arts for Transfer (AA-T) is intended for students who plan to complete a bachelor’s degree in a similar major at a CSU campus. Students completing these degrees (AA-T) are guaranteed admission to the CSU system, but not to a particular campus or major. Students transferring to a CSU campus that does accept the AA-T will be required to complete no more than 60 units after transfer to earn a bachelor’s degree (unless the major is designated “high-unit” major). This degree may not be the best option for students intending to transfer to a particular CSU campus or to a university or college that is not part of the CSU system. Students should consult with a counselor when planning to complete the degree for more information on university admission and transfer requirements.

To earn an Associate in Arts for Transfer (AA-T) students must complete: (1) 18 units of major course requirements with a minimum grade of “C”; (2) California State University General Education Breadth requirements (CSU GE Breadth) or the Intersegmental General Education Transfer Curriculum (IGETC); (3) any elective courses to complete a minimum of 60 units of CSU transferable coursework; (4) have an overall GPA of 2.0.

Required course		Units
COMM 100 C	Human Communication or	3
COMM 100HC	Honors Human Communication	(3)
Restricted Electives List A. Select 6 units.		
Students may choose from the following courses:		
COMM 105 C	Interpersonal Communication	3
COMM 124 C	Small Group Communication	3
COMM 135 C	Argument and Critical Thinking	3
Restricted Electives List B. Select 6 Units.		
Students may choose from any course not used in List A and/or any of the following courses:		
(Forensics — maximum of 3 units)		
COMM 120 C	Intercultural Communication	3
COMM 138 C	Forensics	1–2
COMM 238 C	Forensics	1–2
JOUR 110 C	Global Media	3
Restricted Electives List C. Select 3 units.		
Students may choose from any course not used in Lists A or B or from any of the following courses:		
COMM 220 C	The Rhetoric of the City	3
COMM 220HC	Honors Rhetoric of the City	3
JOUR 101 C	Reporting and Writing	3
PSY 101 C	Introduction to Psychology	3
PSY 101HC	Honors Introduction to Psychology	3
SOC 101 C	Introduction to Sociology	3
SOC 101HC	Honors Intro to Sociology	3
ANTH 102 C	Cultural Anthropology	3
ANTH 102HC	Honors Cultural Anthropology	3
	Total Units	18

COMMUNICATION STUDIES TRANSFER PROGRAM

Students should consult a counselor or www.assist.org for lower division major requirements for most California public universities. (See the Standard Definitions section of the catalog for a description of ASSIST.) Students transferring to an independent college/university should consult the catalog of the individual school and a counselor for lower division major requirements.

Communication Studies (COMM)

COMM 049 C Oral Communication for Advanced Non-Natives 3 Units

Term hours: 48–54 lecture. This course teaches the non-native speaker of English effective communication techniques in everyday situations. Emphasis is placed on developing speaking skills such as pronunciation, articulation, organization and delivery. This course is especially helpful for students who have completed Advanced courses in English as a Second Language. May be taken for credit 2 times. Pass/No Pass/Letter Grade Option.

COMM 050 C Effective Communication 3 Units

Term hours: 48–54 lecture. The course is designed to teach students effective communication techniques in everyday situations. Emphasis is placed on developing communication skills in a variety of settings including interviewing, resume building, public speaking and working in small groups. Pass/No Pass/Letter Grade Option. (AA GE)

COMM 098 C Communication Seminar 5 to 12 Units

Term hours: 0–216 lecture and 0–432 laboratory depending on units attempted. This seminar is for able students who wish to extend their knowledge of literature, language, and culture through small groups discussion. May be taken for credit 1–4 times. Pass/No Pass or Pass/No Pass/Letter Grade Option or Standard Letter Grade. Fee may be required — Payable at Registration.

COMM 100 C Human Communication 3 Units

Term hours: 48–54 lecture. Introduction to the fundamentals and principles which underlie effective speech communication. Practical experience, emphasizing content, organization and delivery, will be required in at least three speaking situations, specifically including persuasive and informative speaking. Duplicate credit not granted for COMM 100HC. (UC Credit Limitation/CSU, AA GE, CSU GE, IGETC)

COMM 100HC Honors Human Communication 3 Units

Term hours: 48–54 lecture. Communication Studies 100HC is a college level course enhanced for Honors students. This course will introduce students to fundamentals and advanced principles which underlie effective speech communication and will offer an overview of the disciplinary field of speech communication. Enhanced practical applications, emphasizing content, organization, and delivery will be required in at least four speaking situations, specifically including persuasive and informative speaking. Principles of rhetorical criticism will also be studied. Duplicate credit not granted for COMM 100 C. (UC Credit Limitation/CSU, AA GE, CSU GE, IGETC)

COMM 105 C Interpersonal Communication 3 Units

Term hours: 48–54 lecture. The purpose of this course is to improve the students' understanding and the ability to deal effectively with people. Major theories in the field of interpersonal communication will be studied so the student can develop a basic understanding of them and also acquire skills for self-improvement. Methods of instruction include lecture, discussion, simulation experiments, and small group activities. No formal speeches required. (CSU/CSU GE)

COMM 120 C Intercultural Communication 3 Units

Advisory: Eligibility for ENGL 100 C.

Term hours: 48–54 lecture. This course focuses on the cultural and social variables, communication theories and practices, and communicative styles that affect the communication process between members of different cultures. It includes an assessment of both the communication problems that occur between members of different cultures and on methods and techniques of adapting communication in an effort to overcome such difficulties. (UC/CSU, CSU GE, IGETC, CUL DIV)

COMM 124 C Small Group Communication 3 Units

Term hours: 48–54 lecture. This course is an introduction to theoretical and applied concepts in small group communication through participation and observation, analysis, and evaluation of group processes. Elements of small group behavior to be studied include leadership, roles, norms, networks, conflict and cohesion needs, and decision making. (UC/CSU)

COMM 135 C Argument and Critical Thinking 3 Units

Term hours: 48–54 lecture. This course is a study of argumentation — logic, reasoning, analysis of issues, audience analysis, evidence, refutation, case construction — and its relationship to advocacy. Emphasis is placed on the development of critical thinking skills. (UC/CSU, AA GE, CSU GE)

COMM 138 C Forensics**1 to 2 Units**

Term hours: 32–36 lecture and 16–18 laboratory. This course is designed to prepare students to participate in intercollegiate speech competition. Practical experience, emphasizing content, organization and delivery will be offered in debate, persuasive speaking, informative speaking, extemporaneous speaking, impromptu speaking and oral interpretation. May be taken for credit 2 times. Open Entry/Open Exit. (CSU, CSU GE)

COMM 220 C The Rhetoric of the City**3 Units**

Term hours: 48–54 lecture. This course will examine the communicative meanings found in the culture, environment, history and social structure for a specific city. Students will be exposed to an interdisciplinary focus on a specific city and will examine the communicative interrelationship between the city and its populace. Duplicate credit not granted for SPCH 220HC. (CSU, AA GE, CSU GE)

COMM 220HC Honors Rhetoric of the City**3 Units**

Term hours: 48–54 lecture. This course is a college level course enhanced for Honors students. This course will be conducted as a seminar. This course will examine the communicative meanings found in the culture, environment, history and social structure of a specific city. Students will be exposed to an interdisciplinary focus on a specific city and will examine the communicative interrelationships between the city and its populace. Duplicate credit will not be granted for COMM 220 C. (CSU, AA GE, CSU GE)

COMM 238 C Forensics**1 to 2 Units**

Term hours: 32–36 lecture and 16–18 laboratory. This course is designed to prepare students to participate in intercollegiate speech competition. Practical experience, emphasizing content, organization and delivery will be offered in debate, persuasive speaking, informative speaking, extemporaneous speaking, impromptu speaking and oral interpretation. May be taken for credit 2 times. Open Entry/Open Exit. (CSU, CSU GE)

COMM 298 C Communication Studies Seminar .5 to 12 Units*Prerequisites: May be required.**Corequisites: May be required.**Advisory: May be required.*

Term hours: 0–216 lecture and 0–432 laboratory depending on units attempted. This seminar is for able students who wish to extend their knowledge of literature, language, and culture through small group discussion. May be taken for credit 1–4 times. Pass/No Pass or Pass/No Pass/Letter Grade Option or Standard Letter Grade. Fee may be required — Payable at Registration. (UC Credit Limitation/CSU)

COMM 299 C Communication Independent Study .5 to 2 Units*Prerequisite: Approved Independent Study Learning Contract.*

Term hours: 8–36 conference depending on units attempted. This course is for able students who wish to increase their knowledge of speech/communication language through individual study or research. May be taken for credit 3 times. (UC Credit Limitation/CSU)

Computer Information Systems

Division of Business and Computer Information Systems

Division Dean — Dave Wassenaar*Faculty*

Patricia Dellinger

Behzad Izadi

Susana Jianto

Richard McKnight

Alireza Moady

Patricia Pelachik

Jesse Saldana

Donna Woo

Penn Wu

Counselor

Robert Grantham

PROGRAM LEARNING OUTCOMES (PLOs)

Computer Application

A student who completes the Computer Application field of study will be able to:

- Demonstrate the knowledge and skills to perform investigation in file system, operating systems, registry, logs, emails, Internet history, or other digital storage media
- Use contemporary software application to create and modify word processing, spreadsheet, database, or presentation files
- Acquire computer application skills to enhance his/her employment opportunity

Computer Networking

A student who completes the Computer Networking field of study will be able to:

- Understand computer networking concepts including network security, and the operation of client and server computers and networking devices
- Acquire hands-on skills to configure, maintain, and troubleshoot client and server computers, and networking devices
- Enhance his/her employment opportunity in the specific area of computer networking

Computer Programming

A student who completes the Computer Programming field of study will be able to:

- Acquire problem analysis skills to design suitable solutions
- Code, debug, implement and maintain the computer programs
- Enhance his/her employment opportunity in the specific area of computer programming

Web Applications and Programming

A student who completes the Web Applications field of study will be able to:

- Demonstrate the knowledge and skills to employ the Internet tools to search the Web, manage email, communicate on the Web, download programs, share information, and strengthen Web security.
- Demonstrate the knowledge and skills to create and implement maintainable Web sites using a range of programming techniques and languages.
- Demonstrate the knowledge and skills to apply a variety of Web site management tools to maintain Web sites.
- Enhance his/her employment opportunity in a specific area of Web applications programming.

ASSOCIATE IN ARTS DEGREE

BUSINESS

Program Code: 1A16599

This curriculum is designed to provide an opportunity for the business major to achieve an Associate in Arts Degree Business while completing the first and second year requirements for transfer to a four-year institution. While a baccalaureate degree is recommended preparation for those considering professional careers in business, completion of this curriculum will demonstrate commitment to the field and provide comprehensive preparation for upper-division work. Students should consult a counselor and the catalog of the individual college or university to plan a program of study. The internet site www.assist.org will also provide information for California public universities. Courses selected to fulfill the requirements of the associate degree should reflect requirements of the college to which the student plans to transfer. To earn an Associate Degree students must complete: (1) all major course requirements with a minimum grade of "C"; (2) California State University General Education Breadth requirements (CSU GE Breadth) or IGETC General Education Plan; (3) any elective courses to complete a minimum of 60 units; (4) complete all graduation requirements; and, (5) have an overall GPA of 2.0. At least 50% of all major course work must be completed at Cypress College. Students pursuing more than one specified departmental major may double count a maximum of 7 units to fulfill major requirements. Courses that fulfill major requirements for an Associate Degree at Cypress College might not be the same as those required for completing the major at a transfer institution offering a Baccalaureate Degree. For information on specific university requirements, please consult with your counselor, or visit the Transfer Center.

Required courses are listed in suggested sequence:		Units
MGT 161 C	Introduction to Business	3
CIS 111 C	Computer Information Systems	3
ECON 100 C	Principles of Economics — Macro	3
	or	
ECON 100HC	Honors Principles of Economics	(3)
ECON 105 C	Principles of Economics — Micro	3
	or	
ECON 105HC	Honors Principles of Economics	(3)
MGT 240 C	Legal Environment of Business	3
	or	
MGT 241 C	Legal Aspects — Business Transactions	(3)
ACCT 101 C	Financial Accounting	4
ACCT 102 C	Managerial Accounting	4
MATH 130 C	Survey of Calculus	4
MKT 222 C	Principles of Marketing	3
Elective		Units
MGT 211 C	Writing for Business	3
Total Units		33

CISCO NETWORKING

CERTIFICATE

Program Code: 1K12937

This curriculum prepares the students for a career in the area of computer networking. The program is designed to teach students the skills needed to design, build, and maintain small to medium-size networks. The certificate totals 12 units in required courses.

To earn a certificate, complete the required courses as listed with a minimum grade of "C." At least 50% of all course work must be completed at Cypress College.

Required courses are listed in suggested sequence:

Course#	Title	Units
CIS 230 C	Cisco Networking 1	3
CIS 231 C	Cisco Networking 2	3
CIS 232 C	Cisco Networking 3	3
CIS 233 C	Cisco Networking 4	3
Total Units Required		12 Units

ASSOCIATE IN SCIENCE DEGREE

COMPUTER APPLICATIONS Program Code: 1S07824

The Associate in Science Degree Computer Applications program provides theoretical and practical knowledge to students in the area of computer applications. This degree program focuses on recent developments and current discoveries in computer applications from academia and business related industries. This degree program is aimed at students who need to apply an understanding of computer applications to an on-the-job learning environment.

To earn an Associate Degree students must complete: (1) all major course requirements with a minimum grade of "C"; (2) 25 units of General Education Graduation Requirements; (3) the cultural diversity and reading requirements; (4) any elective courses to complete a minimum of 60 units; and, (5) have a minimum GPA of 2.0. At least 50% of all major course work must be completed at Cypress College.

Courses that fulfill major requirements for an Associate Degree at Cypress College might not be the same as those required for completing the major at a transfer institution offering a Baccalaureate Degree. For information on specific university requirements, please consult with your counselor, or visit the Transfer Center.

Required Courses are listed in suggested sequence:

Course #	Title	Units
CIS 107 C	Introduction to Windows	1
	or	
CIS 110 C	Linux Operating System	(3)
CIS 108 C	Introduction to Internet	2
CIS 111 C	Computer Information Systems	3
CIS 132 C	Spreadsheet — Excel for Windows	3
CIS 142 C	Database — Access for Windows	3
CIS 160 C	Information Systems Management	3
CIS 182 C	Data Communications Management	3
CIS 211 C	Introduction to Programming	3
CIS 115 C	Desktop Publishing — Publisher	2
CIS 250 C	Word Processing	2
CIS 116 C	Microsoft Outlook/PDA	3
Total Units Required		28–30

COMPUTER APPLICATIONS CERTIFICATE

Program Code: 1C21105

This curriculum gives the student a working knowledge for a career in the area of computer applications. The certificate totals 28–30 units in required courses.

To earn a certificate, students must complete the required courses as listed with a minimum grade of “C.” At least 50% of all course work must be completed at Cypress College.

Required courses are listed in suggested sequence:

Course #	Title	Units
CIS 107 C	Introduction to Windows or Linux Operating Systems	1 (3)
CIS 110 C	Introduction to Internet	2
CIS 108 C	Computer Information Systems	3
CIS 111 C	Spreadsheet — Excel for Windows	3
CIS 132 C	Database — Access for Windows	3
CIS 142 C	Information Systems Management	3
CIS 160 C	Data Communications Management	3
CIS 182 C	Introduction to Programming	3
CIS 211 C	Desktop Publishing — Publisher	2
CIS 115 C	Word Processing	2
CIS 250 C	Microsoft Outlook/PDA	3
CIS 116 C		
Total Units Required		28–30

ASSOCIATE IN SCIENCE DEGREE COMPUTER INFORMATION SYSTEMS

Program Code: 1S03767

This curriculum prepares the student for a career in the area of computer information systems. The program is designed to develop a working knowledge of what is required to be successful in business computer information systems.

To earn an Associate Degree students must complete: (1) all major course requirements with a minimum grade of “C”; (2) 25 units of General Education Graduation Requirements; (3) the cultural diversity and reading requirements; (4) any elective courses to complete a minimum of 60 units; and, (5) have a minimum GPA of 2.0. At least 50% of all major course work must be completed at Cypress College.

Courses that fulfill major requirements for an Associate Degree at Cypress College might not be the same as those required for completing the major at a transfer institution offering a Baccalaureate Degree. For information on specific university requirements, please consult with your counselor, or visit the Transfer Center.

Required courses are listed in suggested sequence:

Course #	Title	Units
ACCT 101 C	Financial Accounting	4
CIS 111 C	Computer Information Systems	3
CIS 132 C	Spreadsheet — Excel for Windows	3
CIS 142 C	Database — Access for Windows	3
CIS 150 C	Microsoft Office Applications	3
CIS 160 C	Information Systems Management	3
CIS 211 C	Introduction to Programming	3
CIS 250 C	Word Processing	2
MGT 111 C	Business Communications or Writing for Business	3 (3)
Total Units Required		27

COMPUTER INFORMATION SYSTEMS CERTIFICATE

Program Code: 1C21104

This curriculum prepares the student for a career in the area of computer information systems. The program is designed to develop a working knowledge of what is required to be successful in business computer information systems. The certificate totals 27 units in required courses.

To earn a certificate, students must complete the required courses as listed with a minimum grade of “C.” At least 50% of all course work must be completed at Cypress College.

Required courses are listed in suggested sequence:

Course #	Title	Units
ACCT 101 C	Financial Accounting	4
CIS 111 C	Computer Information Systems	3
CIS 132 C	Spreadsheet — Excel for Windows	3
CIS 142 C	Database — Access for Windows	3
CIS 150 C	Microsoft Office Applications	3
CIS 160 C	Information Systems Management	3
CIS 211 C	Introduction to Programming	3
CIS 250 C	Word Processing	2
MGT 111 C	Business Communications or Writing for Business	3 (3)
Total Units Required		27

ASSOCIATE IN SCIENCE DEGREE COMPUTER PROGRAMMING

Program Code: 1S03768

This program prepares the student for a career in the area of computer programming. The curriculum is designed to develop a working knowledge of what is required to be successful in business computer programming.

To earn an Associate Degree students must complete: (1) all major course requirements with a minimum grade of “C”; (2) 25 units of General Education Graduation Requirements; (3) the cultural diversity and reading requirements; (4) any elective courses to complete a minimum of 60 units; and, (5) have a minimum GPA of 2.0. At least 50% of all major course work must be completed at Cypress College.

Courses that fulfill major requirements for an Associate Degree at Cypress College might not be the same as those required for completing the major at a transfer institution offering a Baccalaureate Degree. For information on specific university requirements, please consult with your counselor, or visit the Transfer Center.

Required courses are listed in suggested sequence:

Course #	Title	Units
CIS 111 C	Computer Information Systems	3
CIS 211 C	Introduction to Programming	3
CIS 217 C	Visual Basic Programming	3
CIS 223 C	Visual C++ Programming	3
CIS 226 C	Java Programming	3
CIS 218 C	Visual C# Programming	3
Total Units Required		18

**COMPUTER PROGRAMMING
CERTIFICATE** **Program Code: 1C21106**

This program prepares the student for a career in the area of computer programming. The program is designed to develop a working knowledge of what is required to be successful in business computer programming.

To earn a certificate, students must complete the required courses as listed with a minimum grade of "C." At least 50% of all course work must be completed at Cypress College.

Course #	Title	Units
Required 2 core courses are listed in suggested sequence:		
CIS 111 C	Computer Information Systems	3
CIS 211 C	Introduction to Programming	3
Select 2 of the following courses:		
CIS 217 C	Visual Basic Programming	3
CIS 218 C	Visual C# Programming	3
CIS 223 C	Visual C++ Programming	3
CIS 226 C	Java Programming	3
Total Units Required		12

**COMPUTER SOFTWARE AND APPLICATION
CERTIFICATE** **Program Code: 1C31196**

This certificate focuses on introductory business software applications used to manage and format information in word processing, in a spreadsheet or database, for desktop publishing, on the Internet, or as a Web page. Students apply their software application knowledge to on-the-job learning situations.

To earn a certificate, complete the required courses as listed with a minimum grade of "C." At least 50% of all course work must be completed at Cypress College.

Course #	Title	Units
Required courses are listed in suggested sequence:		
CIS 050 C	Intro — Comp and Windows Concepts	3
CIS 101 C	Intro MS Word/Doc Formatting	4
CIS 150 C	Microsoft Office Applications	3
CIS 250 C	Word Processing	2
CIS 115 C	Desktop Publishing — Publisher or	2
CIS 075 C	Business Skills Development	(2)
CIS 103 C	Microsoft Excel and PowerPoint	3
CIS 113 C	MS Access and Expression Web	3
Total Units		20

**GAME PROGRAMMING
CERTIFICATE** **Program Code: 1C31197**

The Game Programming certificate is designed for students who wish to learn the essential game programming skills to get started in the exciting world of computer game software. Upon the completion of all required courses students will have the basic skills required to create gaming environments and scenarios.

To earn a certificate, complete the required courses as listed with a minimum grade of "C." At least 50% of all course work must be completed at Cypress College.

Required courses are listed in suggested sequence:		Units
CIS 211 C	Introduction to Programming	3
CIS 260 C	Game Concepts Development	3
CIS 261 C	Game Programming	3
CIS 263 C	Mobile Game Programming	3
or		
CIS 265 C	3D Game Programming	(3)
CIS 264 C	Windows Game Programming	3
CIS 266 C	Game Programming in Flash	3
Total Units		18

**COMPUTER FORENSICS
CERTIFICATE** **Program Code: 1K30328**

The goal of this program is to equip students with the necessary skills and knowledge required to collect digital artifacts and present them to related parties as digital evidence. Students will learn how to process cases from start to finish in addition to the use of software toolkits. To earn a certificate, complete the required courses as listed with a minimum grade of "C." At least 50% of all course work must be completed at Cypress College.

Students who successfully complete the following required courses are eligible for applying for certification in Computer Forensics:

Course #	Title	Units
CIS 276 C	Computer Forensics I	3
CIS 277 C	Computer Forensics II	3
CIS 278 C	Cyber Crime	3
CIS 279 C	Comp Forensics Legal Aspects	3
CIS 280 C	Analysis of Digital Media	3
CIS 281 C	Computer Forensics Capstone	3
Total Units		18

**INTERNET AND DATA COMMUNICATIONS
CERTIFICATE** **Program Code: 1C31198**

This certificate program provides theoretical and practical knowledge to students in the areas of Personal Computer Networking, Internet, and Web Publishing. This certificate program focuses on recent developments and current discoveries in data communications and Web technologies.

To earn a certificate, complete the required courses as listed with a minimum grade of "C." At least 50% of all course work must be completed at Cypress College.

Required courses are listed in suggested sequence:		Units
CIS 108 C	Introduction to Internet	2
CIS 109 C	E-Business Applications	3
CIS 155 C	Microsoft Expression Web Apps	3
or		
CIS 157 C	Dreamweaver Business Apps	(3)
CIS 179 C	Intro to Web Page Design	3
CIS 182 C	Data Communications Management	3
CIS 220 C	Web Page Programming	3
or		
CIS 227 C	Java Script Programming and AJAX	(3)
Total Units		17

PC/NETWORK HARDWARE SUPPORT CERTIFICATE

Program Code: 1K30330

This certificate is intended for those individuals who need to gain hands-on practice and competency in core hardware related to both PC and network operating system technologies. Upon completion of all required courses, students will be able to recognize major personal computer components including their functions, and configure the most common technical problems associated with a personal computer in both stand-alone and networking platforms. Special emphasis is focused on hands-on skills with PC hardware and software installation and troubleshooting in a networked environment. To earn a certificate, complete the required courses as listed with a minimum grade of "C." At least 50% of all course work must be completed at Cypress College.

Required courses are listed in suggested sequence:		Units
CIS 161 C	PC Operating System	3
CIS 162 C	PC Hardware Configurations	3
CIS 163 C	Intro to Network Hardware	3
CIS 164 C	Computer Desktop Support	3
CIS 182 C	Data Communications Management	3
	or	
CIS 185 C	Windows Server Administration	(3)
Total Units		15

MICROSOFT NETWORKING CERTIFICATE

Program Code: 1K30331

This certificate program prepares students for a certificate in the administration of a Microsoft network in today's businesses. This program includes skills in planning, designing, implementing, and managing a Microsoft network. It is intended for those individuals who need to gain skills in day-to-day general network administration, configuration, and support tasks.

To earn a certificate, students must complete the required courses as listed with a minimum grade of "C." At least 50% of all course work must be completed at Cypress College.

Required courses are listed in suggested sequence:		Units
Course #	Title	
CIS 184 C	Windows Client Administration	3
CIS 185 C	Windows Server Administration	3
CIS 189 C	MS Windows Active Directory	3
CIS 191 C	Network Infrastructure Admin.	3
CIS 194 C	Internet Security (ISA) Server	3

Take 1 of the following courses:

CIS 182 C	Data Communications Management	3
CIS 187 C	MS Windows Exchange Server	3
CIS 188 C	Microsoft Windows TCP/IP	3
CIS 197 C	Microsoft Network Design	3
Total Units Required		18

NETWORK VIRTUALIZATION CERTIFICATE

Program Code: 1C31329

This certificate is designed to provide students with the key virtualization techniques and the applications of virtualization technology in the design, planning, implementation, management, and evaluation of virtualized enterprise infrastructure including computational clouds. The certificate covers recent trends in virtualization including the current wave of virtualization technology from both VMware and Microsoft. To earn a certificate, complete the required courses as listed with a minimum grade of "C." At least 50% of all course work must be completed at Cypress College.

Required courses are listed in suggested sequence:		Units
CIS 185 C	Windows Server Administration	3
CIS 189 C	MS Windows Active Directory	3
CIS 163 C	Intro to Network Hardware	3
CIS 201 C	MS Virtualization Network	3
CIS 202 C	VMware Virtualization Network	3
Total Units		15

WEB NETWORKING TECHNOLOGY CERTIFICATE

Program Code: 1K30329

The Web Networking Technology Certificate is designed to prepare students with the focused knowledge and understanding of collaborative Web technologies. The curriculum covers the use of the Internet to enhance interconnectivity and interactivity of Web-delivered contents including information sharing, social networking, publishing and posting information on the Web, and developing interactive and collaborative Web sites.

To earn a certificate, complete the required courses as listed with a minimum grade of "C." At least 50% of all course work must be completed at Cypress College.

Required courses are listed in suggested sequence:		Units
CIS 120 C	Advanced Internet Applications	3
CIS 121 C	Adobe PDF Document Management	3
CIS 155 C	Microsoft Expression Web Apps	3
	or	
CIS 157 C	Dreamweaver Business Apps	(3)
CIS 179 C	Intro to Web Page Design	3
CIS 221 C	Web Networking Technology	3
CIS 262 C	New Technology	3
Total Units		18

**WEB PAGE DESIGN
CERTIFICATE**

Program Code: 1K30334

This certificate focuses on the current development in Web page technologies used in academia and the business industry. This certificate prepares students to design and modify Web pages using current software programs or programming languages and apply their knowledge to on-the-job learning situations.

To earn a certificate, students will complete the required courses as listed with a minimum grade of "C." At least 50% of all course work must be completed at Cypress College.

Required courses are listed in suggested sequence:		Units
CIS 108 C	Introduction to Internet	2
CIS 109 C	E-Business Applications	3
CIS 155 C	Microsoft Expression Web Apps	3
	or	
CIS 157 C	Dreamweaver Business Apps	(3)
CIS 179 C	Intro to Web Page Design	3
CIS 211 C	Introduction to Programming	3
CIS 220 C	Web Page Programming	3
	or	
CIS 227 C	Java Script Programming and AJAX	(3)
	Total Units	17

**ADVANCED WEB PAGE DESIGN
CERTIFICATE**

Program Code: 1K30335

The Advanced Web Page Design Certificate offers advanced and latest programming technologies in the area of Web publishing and Web site management with e-commerce capabilities. Students will learn how to implement a full-featured Web site on the Internet or a corporate Intranet including deploying dynamic content using related tools. This certificate is designed for students who need to apply for positions such as Web Programmer, Web Master, Web Page Designer, Marketing and Advertising Coordinator, and Web Technical Support.

To earn a certificate, complete the required courses as listed with a minimum grade of "C." At least 50% of all course work must be completed at Cypress College.

Required courses are listed in suggested sequence:		Units
CIS 179 C	Intro to Web Page Design	3
CIS 220 C	Web Page Programming	3
CIS 245 C	Perl Programming	3
CIS 247 C	Python Programming	3
CIS 246 C	PHP Programming	3
	Take 1 of the following courses:	Units
CIS 222 C	Web Server Management	3
CIS 225 C	Web Programming with ASP	3
CIS 227 C	Java Script Programming and AJAX	3
CIS 229 C	Intro to XML Programming	3
	Total Units	18

**ADVANCED NETWORKING
CERTIFICATE**

Program Code: 1K30332

This curriculum focuses on advanced networking concepts such as network security, voice over IP, wireless LANS and Microsoft networking services. Special emphasis is on developing hands-on skills with advanced networking equipment.

To earn a certificate, students must complete the required courses as listed with a minimum grade of "C." At least 50% of all course work must be completed at Cypress College.

Required courses are listed in suggested sequence:		
Course #	Title	Units
Take 1 of the following courses:		
CIS 182 C	Data Communications Management	3
CIS 185 C	Windows Server Administration	3
CIS 191 C	Network Infrastructure	3
Take 2 of the following courses:		
CIS 239 C	CCNA Bootcamp	3
CIS 240 C	Cisco Wireless Networking	3
CIS 248 C	Voice Over IP	3
Take 2 of the following courses:		
CIS 187 C	MS Windows Exchange Server	3
	or	
CIS 194 C	Internet Security (ISA) Server	(3)
CIS 195 C	Network Security	3
CIS 196 C	Anti-Hacking Network Security	3
CIS 258 C	CCNA Security	3
	Total Units Required	15

**ASSOCIATE IN ARTS DEGREE
COMPUTER AND OFFICE
APPLICATIONS**

Program Code: 1A31209

The Associate in Arts Degree Computer and Office Applications program provides theoretical and practical knowledge to students in the area of computer applications used in an office setting. This degree program focuses on recent computer applications used in a wide variety of government, academia, and business-related settings. This degree program is aimed at students who need to apply an understanding of computer applications to an on-the-job learning environment.

To earn an Associate Degree students must complete: (1) all major course requirements with a minimum grade of "C"; (2) 25 units of General Education Graduation Requirements; (3) the cultural diversity and reading requirements; (4) any elective courses to complete a minimum of 60 units; and, (5) have a minimum GPA of 2.0. At least 50% of all major course work must be completed at Cypress College.

Required Courses are listed in suggested sequence:		Units
CIS 101 C	Intro MS Word/Doc Formatting	4
CIS 102 C	Advanced MS Word Business Apps	4
CIS 103 C	Microsoft Excel and PowerPoint	3
CIS 150 C	Microsoft Office Applications	3
CIS 113 C	MS Access and Expression Web	3
CIS 116 C	MS Outlook/Office Procedures	3
CIS 250 C	Word Processing	2
CIS 251 C	Advanced Word Processing	2
CIS 160 C	Information Systems Management	3
CIS 111 C	Computer Information Systems	3
	Total Units	30

COMPUTER AND OFFICE APPLICATIONS CERTIFICATE

Program Code: 1C33193

This curriculum gives the student a working knowledge for a career in computer applications in an office setting. Upon completion, the student will work in the capacity of office assistant, computer application specialist, or administrative assistant. To earn a certificate, students must complete the required courses as listed with a minimum of "C" grade. At least 50% of all course work must be completed at Cypress College.

Required Courses are listed in suggested sequence:		Units
CIS 101 C	Intro MS Word/Doc Formatting	4
CIS 102 C	Advanced MS Word Business Apps	4
CIS 103 C	Microsoft Excel and PowerPoint	3
CIS 150 C	Microsoft Office Applications	3
CIS 113 C	MS Access and Expression Web	3
CIS 116 C	MS Outlook/Office Procedures	3
CIS 160 C	Information Systems Management	3
CIS 250 C	Word Processing	2
CIS 251 C	Advanced Word Processing	2
Total Units		27

OFFICE ASSISTANT CERTIFICATE

Program Code: 1C31199

To prepare students for a variety of occupational office positions with a basic understanding of computer software.

To earn a certificate, complete the required courses as listed with a minimum grade of "C." At least 50% of all course work must be completed at Cypress College.

Required courses are listed in suggested sequence:		Units
CIS 050 C	Intro — Comp and Windows Concepts	3
CIS 101 C	Intro MS Word/Doc Formatting	4
CIS 150 C	Microsoft Office Applications	3
CIS 116 C	MS Outlook/Office Procedures	3
MGT 055 C	Business English	3
Total Units		16

COMPUTER INFORMATION SYSTEMS TRANSFER PROGRAM

Students should consult a counselor or www.assist.org for lower division major requirements for most California public universities. (See the Standard Definitions section of the catalog for a description of ASSIST.) Students transferring to an independent college/university should consult the catalog of the individual school and a counselor for lower division major requirements.

Computer Information Systems (CIS)

CIS 050 C Introduction to Computer and Windows Concepts **3 Units**

Term hours: 48–54 lecture and 16–18 laboratory. This course is designed to teach the computer hardware, Windows, Email, and Internet concepts. Students will receive hands-on experience. Students may elect to take this class as preparation for CIS 111 C, CIS 150 C, or CIS 250 C. Non-Degree Credit. Pass/No Pass/Letter Grade Option. \$3.00 Laboratory Fee — Payable at Registration.

CIS 075 C Business Skills Development **.5 to 10 Units**

Term hours: 8–180 lecture and 24–540 laboratory TBA depending on units attempted. This variable unit, open entry/open exit course with flexible hours is designed for the student who needs to gain marketable job skills in a short period of time. Occupational training will be provided in the areas of computer applications, information processing, office occupations, and communication skills. May be taken for a cumulative total of 10 units. Open Entry/Open Exit. Pass/No Pass/Letter Grade Option. \$3.00 Materials Fee — Payable at Registration.

CIS 101 C Introduction to MS Word/Document Formatting **4 Units**

Term hours: 48–54 lecture and 48–54 laboratory. Students will learn to build speed and accuracy using the touch method and learn to format letters, table, memos, and reports using Microsoft Word. May be taken for credit 4 times. Pass/No Pass/Letter Grade Option. \$3.00 Materials Fee — Payable at Registration. (CSU)

CIS 102 C Advanced MS Word Business Applications **4 Units**

Term hours: 48–54 lecture and 48–54 laboratory. This course teaches the student how to create and format business, legal and medical documents using Microsoft Word. Focus will be on using Word features such as mail merge, styles, graphics, etc. to generate letters, tables, reports and newsletters. Cloud computing, using Web Apps, posting blogs and using the SkyDrive will be taught. Pass/No Pass/Letter Grade Option. \$3.00 Material Fee — Payable at Registration. (CSU)

CIS 103 C Microsoft Excel and PowerPoint **3 Units**

Advisory: CIS 101 C, or CIS 125 C, or a basic knowledge of MS Word and the ability to type 20 wpm.

Term hours: 48–54 lecture and 32–36 laboratory. This course teaches the student how to use Excel and PowerPoint for business and professional use. This course provides the student with the knowledge and skills necessary to take the Core level Microsoft Office Specialist Excel and Comprehensive PowerPoint exams. Pass/No Pass/Letter Grade Option. \$3.00 Material Fee — Payable at Registration. (CSU)

CIS 107 C Introduction to Windows **1 Unit**

Term hours: 16–18 lecture and 16–18 laboratory TBA. This course is designed to use Microsoft Windows on the personal computer. It covers the graphical user interface, and how to manipulate Windows, using Help, and launching Applications. \$3.00 Materials Fee — Payable at Registration. (CSU)

CIS 108 C Introduction to Internet **2 Units**

Term hours: 32–36 lecture and 16–18 laboratory. This course will prepare students to use the Internet, a worldwide computer network. Emphasis is on introducing the features of the Internet, including electronic mail, Telnet, FTP (File Transfer Protocol), Usenet, and Gopher, as well as other Internet services and utilities. Students will explore the vast resources of the Internet and learn to access information using a variety of hands-on methods. Pass/No Pass/Letter Grade Option. \$3.00 Materials Fee — Payable at Registration. (CSU)

CIS 109 C E-Business Applications **3 Units**

Term hours: 48–54 lecture and 16–18 laboratory. This course introduces the technological infrastructure needed for implementing e-Business solutions. It also discusses the software components necessary to implement such applications. A major component of the course will be hands-on projects of evaluating e-business tools and application software. \$3.00 Material Fee — Payable at Registration. (CSU)

CIS 110 C Linux Operating System 3 Units

Term hours: 48–54 lecture and 32–36 laboratory TBA. This course is an introduction to the Linux operating system. Topics include installing, configuring, maintaining, administering, and troubleshooting of the Linux Operating System. It provides preparation for the Sair Linux Certification. \$3.00 Materials Fee — Payable at Registration. (CSU)

CIS 111 C Computer Information Systems 3 Units

Term hours: 48–54 lecture and 16–18 laboratory. This course is an introduction to computer concepts, computer organization, operation, hardware, systems and application software; business-problem solving; and applications to business. \$3.00 Material Fee — Payable at Registration. (UC/CSU, AA GE, CSU GE)

CIS 113 C MS Access and Expression Web 3 Units

Term hours: 32–36 lecture and 48–54 laboratory. This course teaches the student how to use Expression Web and Access for business and professional use. This course provides the student with the knowledge and skills necessary to take the Specialist level of the Microsoft Office Access and Web Expression exams. \$3.00 Materials Fee — Payable at Registration. Pass/No Pass/Letter Grade Option. (CSU)

CIS 115 C Desktop Publishing — Publisher 1 to 2 Units

Term hours: 8–18 lecture and 24–54 laboratory TBA depending on units attempted. This class is designed for office support staff, secretaries, administrative assistants, small business owners, and others who require a basic knowledge of business desktop publication applications. This course uses Microsoft Office Publisher. May be taken for credit 2 times. Open Entry/Open Exit. Pass/No Pass/Letter Grade Option. \$3.00 Material Fee — Payable at Registration. (CSU)

CIS 116 C MS Outlook/Office Procedures 3 Units

Term hours: 48–54 lecture and 16–18 laboratory. This course prepares management or office personnel for work in a computerized office environment. MS Outlook is taught in this class and integrated with Word and other MS office applications. \$3.00 Material Fee — Payable at Registration. (CSU)

CIS 120 C Advanced Internet Applications 3 Units

Term hours: 48–54 lecture and 16–18 laboratory. This course provides students an opportunity to develop an understanding of various Internet applications. In doing this, students will study the Internet fundamentals, client/server applications, networking, Web site development, Internet security, and E-commerce. At the completion of this course, students will learn Internet, Intranet, and Extranet services and technologies. Pass/No Pass/Letter Grade Option. \$3.00 Material Fee — Payable at Registration. (CSU)

CIS 121 C Adobe PDF Document Management 3 Units

Term hours: 48–54 lecture and 32–36 laboratory TBA. This class is designed to teach students to use Adobe Acrobat Professional to convert technical documents to PDF (Portable Document Format) files. Students will prepare, edit, and format PDF documents, enhance and control PDF accessibility features, create interactive documents that can be shared via email and the Web, and prepare PDF documents for commercial printing. \$3.00 Materials Fee — Payable at Registration. (CSU)

CIS 132 C Spreadsheet — Excel for Windows 3 Units

Term hours: 48–54 lecture and 32–36 laboratory TBA. This course is designed to introduce students to the use of spreadsheet programs in the solution of problems. Students will use spreadsheet software to create, edit, graph, save, and print out spreadsheets. \$3.00 Material Fee — Payable at Registration. (CSU)

CIS 142 C Database — Access for Windows 3 Units

Term hours: 48–54 lecture and 32–36 laboratory TBA. This course is designed to introduce the student to the use of database programs in the solution of record keeping problems. Students will use database software to create, update, and report data files. \$3.00 Material Fee — Payable at Registration. (CSU)

CIS 150 C Microsoft Office Applications 3 Units

Term hours: 48–54 lecture and 16–18 laboratory. This course studies the terms, concepts, and features of Microsoft Office software in today's business office. Students will create hands-on application office projects using Microsoft Office. May be taken for credit 4 times. Pass/No Pass/Letter Grade Option. \$3.00 Material Fee — Payable at Registration. (CSU)

CIS 155 C Microsoft Expression Web Apps 3 Units

Term hours: 48–54 lecture and 16–18 laboratory. This course offers the introductory and advanced features of Microsoft Expression Web and how it can be utilized in creating personal and business Web applications. Topics include introducing Expression Web, creating and revising Web pages, using links, images, and task lists, creating tables, frames, borders, form applications, and dynamic Web templates. In addition, students will explore HyperText Markup Language (HTML), Extensible HyperText Markup Language (XHTML), and Cascading Style Sheets (CSS) Web techniques. Pass/No Pass/Letter Grade Option. \$3.00 Material Fee — Payable at Registration. (CSU)

CIS 157 C Dreamweaver Business Apps 3 Units

Advisory: MAD 103 C or by consent of Instructor.

Term hours: 48–54 lecture and 16–18 laboratory. This course covers advanced topics in Adobe Dreamweaver. Topics include using layers, styles, templates, library elements, and automation to create Web pages. In addition, the course offers several features to create dynamic and database-driven Web application sites. Pass/No Pass/Letter Grade Option. \$3.00 Materials Fee — Payable at Registration. (CSU)

CIS 160 C Information Systems Management 3 Units

Term hours: 48–54 lecture and 32–36 laboratory TBA. This course is for students interested in managing a Computer Information Systems Center. The subject areas to be studied are planning, equipping, staffing, and managing a computerized business office. The student will use a computer spreadsheet and database in hands-on exercises in planning and managing an information systems office. \$3.00 Materials Fee — Payable at Registration. (CSU)

CIS 161 C PC Operating System 3 Units

Term hours: 48–54 lecture and 16–18 laboratory. The course uses the latest version of Windows to introduce students to the technical aspects of an operating system program. This course takes students from the fundamental concepts of modern computer operating systems, and leads them into more advanced topics and network implementation. Topics include installing, configuring, upgrading, diagnosing, and troubleshooting desktop operating systems. Pass/No Pass/Letter Grade Option. \$3.00 Material Fee — Payable at Registration. (CSU)

CIS 162 C PC Hardware Configurations 3 Units

Term hours: 48–54 lecture and 16–18 laboratory. This course prepares students with both theoretical and practical lessons relating to Microcomputer hardware. Emphasis is placed on how hardware components function together to make a Microcomputer work properly, how software interacts with hardware, and practical methods to protect hardware and software. Topics include installing, configuring, and upgrading personal computer components and peripherals in a networked environment. Pass/No Pass/Letter Grade Option. \$3.00 Material Fee — Payable at Registration. (CSU)

CIS 163 C Introduction to Network Hardware 3 Units

Term hours: 48–54 lecture and 16–18 laboratory. This course builds on students' knowledge of basic networking concepts and theory through hands-on experience. The course will provide students with an in-depth understanding of network infrastructure, standards, and technologies. Students will gain hands-on experience with current network design issues, protocol, and components. Hands-on experience will also include working with wired and wireless standards and network components such as servers, routers, switches, hubs, and firewalls. Pass/No Pass/Letter Grade Option. \$3.00 Material Fee — Payable at Registration. (CSU)

CIS 164 C Computer Desktop Support 3 Units

Term hours: 48–54 lecture and 16–18 laboratory. This class is designed to teach students the crucial skills needed to work as a computer end-user support in an Active Directory network environment or Windows work-group environment as well as how to troubleshoot applications running in Microsoft Windows platform. Students will learn the kinds of knowledge, skills, abilities, and strategies they need to be employable in the support industry. Emphasis will be placed on end-user computing, communication and customer service skills of user support staff, problem solving strategies, common support problems, and technical skills required for user support positions. This course prepares students for the Microsoft Certified Desktop Support Technician curriculum (MCDST). Pass/No Pass/Letter Grade Option. \$3.00 Material Fee — Payable at Registration. (CSU)

CIS 179 C Introduction to Web Page Design 3 Units

Term hours: 48–54 lecture and 16–18 laboratory. This course introduces students to Web publishing with HTML (HyperText Markup Language) for business and personal applications. Students will learn fundamentals of the Internet and how to employ HTML techniques to convey their messages, and design a professional-looking Web site. Emphasis is placed on learning the HyperText Markup Language from the basic tags to the advanced topics such as tables, forms, graphics, and creation of the business-related Web pages. \$3.00 Material Fee — Payable at Registration. (CSU)

CIS 182 C Data Communications Management 3 Units

Term hours: 48–54 lecture and 16–18 laboratory. The course provides a comprehensive introduction of the fundamental concepts and theory of data communications. Students will understand basic networked communications and identify essential technical and operational components. Topics include communication concepts, communication components and hardware, communication media, topologies, protocols, local and wide area networks, network administration and support, and wireless communications. Students will use their computers to examine Windows related network administration commands during the lecture. It is designed for every one with an interest in data communications and system administration. Pass/No Pass/Letter Grade Option. \$3.00 Material Fee — Payable at Registration. (CSU)

CIS 184 C Windows Client Administration 3 Units

Term hours: 48–54 lecture and 16–18 laboratory. This course introduces students to Microsoft Client for Windows on the personal computer. Students will learn the features and architecture of the Windows operating system. This course will cover an overview of the Windows program installation, working with files and folders, how to manipulate Windows printing system, configuring local group policy as well as client software, user management, and monitoring system performance. Pass/No Pass/Letter Grade Option. \$3.00 Material Fee — Payable at Registration. (CSU)

CIS 185 C Windows Server Administration 3 Units

Term hours: 48–54 lecture and 16–18 laboratory. This course introduces students to the Microsoft Windows Server Management and enterprise networks. Topics include installing the server operating system, administering user accounts, managing system resources, installing active directory, and implementing DNS service. May be taken for credit 3 times. Pass/No Pass/Letter Grade Option. \$3.00 Material Fee — Payable at Registration. (CSU)

CIS 187 C MS Windows Exchange Server 3 Units

Term hours: 48–54 lecture and 16–18 laboratory. This course introduces students to the administration of Microsoft Exchange Server. Students learn an overview of the Exchange Server environment, installing and administering Exchange Server, user and database management, and operating Exchange Server in a networking environment. Emphasis is placed on installing and administering Exchange Server, setting up user accounts and user access, and managing resources. Students should be familiar with using Microsoft Windows Server Operating System. Pass/No Pass/Letter Grade Option. \$3.00 Material Fee — Payable at Registration. (CSU)

CIS 188 C Microsoft Windows TCP/IP 3 Units

Term hours: 48–54 lecture and 16–18 laboratory. This course increases student knowledge of the Transmission Control/Internet Protocol (TCP/IP) by introducing theory on how the protocol functions, installation and configuration techniques, and utilities to manage a TCP/IP based network. Topics include TCP/IP theory and operation, installing TCP/IP on a Microsoft network, configuring protocol settings, troubleshooting, and managing a TCP/IP network. Students should be familiar with the basic concepts of data communications and using Microsoft Windows operating system. Pass/No Pass/Letter Grade Option. \$3.00 Material Fee — Payable at Registration. (CSU)

CIS 189 C MS Windows Active Directory 3 Units

Term hours: 48–54 lecture and 16–18 laboratory. This course introduces students to Microsoft Windows Active Directory and enterprise networks. Students learn an overview of the Windows operating system in a networked environment, installing and administering DNS servers, Active Directory management and networking. Emphasis is placed on managing a Windows Active Directory network, setting up user accounts and user access, and managing resources. Students should be familiar with the basic concepts of data communications and using Microsoft Windows operating system. Pass/No Pass/Letter Grade Option. \$3.00 Material Fee — Payable at Registration. (CSU)

CIS 191 C Network Infrastructure Admin 3 Units

Term hours: 48–54 lecture and 16–18 laboratory. This course provides students with the knowledge and skills necessary to manage, monitor, troubleshoot, and support a Microsoft enterprise network. Emphasis is placed on analyzing the requirements of business organizations for implementing a reliable network infrastructure strategy. Emphasis is placed on the underlying services and protocols such as DNS (Domain Naming Service), DHCP (Dynamic Host Configuration Protocol), Remote Access, Network Protocols, IP (Internet Protocol) Routing, VPN (Virtual Private Network), and WINS (Windows Internet Naming Service). Pass/No Pass/Letter Grade Option. \$3.00 Material Fee — Payable at Registration. (CSU)

CIS 194 C Internet Security (ISA) Server 3 Units

Term hours: 48–54 lecture and 16–18 laboratory. This course prepares students to install and configure the Microsoft Internet Security and Acceleration Server (ISA) Enterprise Edition. Students will gain knowledge of how to use the Microsoft ISA server as both a firewall and web-caching server. Topics include installing the ISA server; configuring and troubleshooting the ISA server services; configuring, managing, and troubleshooting policies and rules; deploying, configuring, and troubleshooting the client computer; and monitoring, managing, and analyzing the ISA server use. Pass/No Pass/Letter Grade Option. \$3.00 Material Fee — Payable at Registration. (CSU)

CIS 195 C Network Security 3 Units

Term hours: 48–54 lecture and 16–18 laboratory. This course prepares students to identify network security threats and implement procedures for securing networks. Topics include authentication, attacks and malicious codes, intruder detection, remote access security, web security, email security, directory service and file transfer security, and firewalls. Pass/No Pass/Letter Grade Option. \$3.00 Material Fee — Payable at Registration. (CSU)

CIS 196 C Anti-Hacking Network Security 3 Units

Term hours: 48–54 lecture and 16–18 laboratory. This course prepares students to analyze past attacks and to learn how these attacks could have been prevented. It also provides training in protecting networks by using an attackers knowledge to compromise network security. Topics include footprinting, port scanning, enumeration, hacking Microsoft Windows and Unix operating system platforms, VPN hacking, firewalls, advanced techniques, and Web hacking. Pass/No Pass/Letter Grade Option. \$3.00 Material Fee — Payable at Registration. (CSU)

CIS 197 C Microsoft Network Design 3 Units

Term hours: 48–54 lecture and 16–18 laboratory. This course prepares students to work with the Microsoft network operating systems in medium to very large business environments. Emphasis will be placed on how to analyze an organization's business needs for designing a network infrastructure as well as a directory services infrastructure. Network infrastructure elements include: analyzing business requirements, analyzing technical requirements, designing a Microsoft network infrastructure, designing for internet connectivity, designing a wide area network infrastructure, and designing a management strategy for Microsoft networking. Directory services elements include: analyzing an organization's business needs for designing a directory services infrastructure. In addition, students will learn through hands-on practices, the four steps of active directory infrastructure design process including creating a forest plan, a domain plan, an organizational unit (OU) plan and a site topology plan. Pass/No Pass/Letter Grade Option. \$3.00 Material Fee — Payable at Registration. (CSU)

CIS 198 C Microsoft Network Exams Prep. 3 Units

Term hours: 32–36 lecture and 32–36 laboratory. This course prepares students for Microsoft Certification exams in Windows Client/Server Administration, Network Infrastructure, and Active Directory. Students will use exam certification simulators during the course to create a simulation of actual certification questions in novel and creative ways. Upon course completion, students will be prepared for Microsoft Certified Professional (MCP) exams. Pass/No Pass/Letter Grade Option. \$3.00 Material Fee — Payable at Registration. (CSU)

CIS 201 C MS Virtualization Network 3 Units

Term hours: 48–54 lecture and 16–18 laboratory. This course prepares students to plan, implement, and manage a Microsoft virtualized enterprise infrastructure. Virtualization technologies such as Microsoft Windows Server with Hyper-V, Remote Desktop Services, Microsoft Enterprise Desktop Virtualization, and Application Virtualization as well as supporting applications and utilities will be discussed. It is recommended ONLY for students with strong knowledge in networking. May be taken for credit 2 times. \$3.00 Material Fee — Payable at Registration. (CSU)

CIS 202 C VMware Virtualization Network 3 Units

Advisory: CIS 201 C or consent of instructor.

Term hours: 48–54 lecture and 16–18 laboratory. In this hands-on training course students will install, configure, manage, and troubleshoot a VMware virtual network. It begins to explore desktop virtualization and cloud environment, and continues to examine concepts and capabilities of virtual architecture with a focus on the installation, configuration, and management of a virtual infrastructure. In doing so, it covers fundamentals of virtual network design and implementation, fundamentals of storage area networks, virtual switching, virtual system management, and engineering for high availability. It is recommended ONLY for students with strong knowledge in networking. Pass/No Pass/Letter Grade Option. \$3.00 Material Fee — Payable at Registration. (CSU)

CIS 211 C Introduction to Programming 3 Units

Term hours: 48–54 lecture and 16–18 laboratory. This beginning course in programming introduces students to the Visual C# .NET and Visual Basic .NET programming languages. Students will learn how to design, code, and debug programs common to the business environment. Some of the topics include: Program Design, Control Structures, Functions, Sub Procedures, Form Design, and Object-Oriented coding. \$3.00 Material Fee — Payable at Registration. (UC/CSU)

CIS 216 C Microsoft Project 3 Units

Term hours: 48–54 lecture and 32–36 laboratory TBA. This course uses Microsoft Project to create a task list, set up and assign resources, format and print plan, track progress, share project information, and manage project team. Students will learn how to solve typical project and business problems using the planning, control and reporting features of Microsoft Project. \$3.00 Material Fee — Payable at Registration. (CSU)

CIS 217 C Visual Basic Programming 3 Units

Prerequisite: CIS 211 C.

Term hours: 48–54 lecture and 16–18 laboratory. This course introduces students to the Visual Basic programming language. Students will learn how to design, code, and debug programs common to the business environment. Some of the topics include: Form Design, Sub Procedures, Functions, Object-Oriented Programming, Arrays, and Accessing DataBase Files. \$3.00 Material Fee — Payable at Registration. (UC/CSU)

CIS 218 C Visual C# Programming 3 Units

Prerequisite: CIS 211 C.

Term hours: 48–54 lecture and 16–18 laboratory. This course introduces students to the Visual C# programming language. Students will learn how to design, code, and debug programs common to the business environment. Some of the topics include: Classes and Objects, Methods, Arrays, and Form Development. \$3.00 Material Fee — Payable at Registration. (CSU)

CIS 219 C Advanced Visual Basic 3 Units

Prerequisite: CIS 217 C Visual Basic Programming.

Term hours: 48–54 lecture and 16–18 laboratory. This is an advanced course in Visual Basic programming. Special emphasis will be placed on the application of the Visual Basic language to solve business problems, including requirements definition, design, construction, testing, and documenting. Multiple forms, objects, controls, Object Linking and Embedding (OLE), and the use of the data control object to interface with databases external to Visual Basic .NET will be covered. \$3.00 Material Fee — Payable at Registration. (CSU)

CIS 220 C Web Page Programming 3 Units

Term hours: 48–54 lecture and 16–18 laboratory. Students will learn how to create Web pages that include Cascading Style Sheets (CSS), how to create JavaScript programs inside HTML (Hyper Text Markup Language) documents, how to use JavaScript programs to enhance Web pages, and how to use elements of Dynamic HTML. Emphasis is placed on multiple page layers, scripting, and managing large-scale Web sites. Using these tools and techniques, students will learn to create dynamic effects based on users interaction, simple animation, drop-down menu, and other sophisticated and useful design effects. Pass/No Pass/Letter Grade Option. \$3.00 Material Fee — Payable at Registration. (CSU)

CIS 221 C Web Networking Technology 3 Units

Term hours: 48–54 lecture and 16–18 laboratory. This course introduces students to the new concept in the Web technology called the Collaborative Internet. The term refers to the use of the Internet technology to enhance information sharing, interactive and collaborative Web sites, social networking, publishing and posting information on the Web, and active participation among Web users. Emphasis is placed on the various applications of this emerging Web technology such as Podcasts, Blogs, Wikis, Mashups, RSS (Really Simple Syndication) Feeds, Flickr, collaborative favorites, and social networks in both theoretical and practical frameworks. Pass/No Pass/Letter Grade Option. \$3.00 Material Fee — Payable at Registration. (CSU)

CIS 222 C Web Server Management 3 Units

Term hours: 48–54 lecture and 16–18 laboratory. This course presents advanced topics in Web site development and maintenance. Emphasis is placed on web programming, client/server scripting, and Web server configuration. Other topics include how to design effective user interfaces, how to process user data with forms, how to configure a Web server, and how to write a script in PERL (Practical Extraction and Report Language), as well as in CGI (Common Gateway Interface). Students should have a working knowledge of Hyper Text Markup Language (HTML) and JavaScript. Pass/No Pass/Letter Grade Option. \$3.00 Material Fee — Payable at Registration. (CSU)

CIS 223 C Visual C++ Programming 3 Units

Prerequisite: CIS 211 C.

Term hours: 48–54 lecture and 16–18 laboratory. This course introduces students to the Visual C++ programming language. Students will learn how to design, code, and debug programs common to the business environment. Some of the topics include: Control Structures, Functions, Classes and Objects, Arrays, and File Processing. \$3.00 Material Fee — Payable at Registration. (UC/CSU)

CIS 225 C Web Programming with ASP 3 Units

Term hours: 48–54 lecture and 16–18 laboratory. This course prepares students to use ASP (Active Server Pages) as a web programming language to create dynamic, interactive, and data-driven web applications. Students will learn how to develop web applications that interact with viewers as well as with other computer applications. Emphasis is placed on reading and writing data to a file on the web server, developing interactive web pages, creating web applications that integrate data bases, server-side programming, optimizing the performance of web applications, developing user controls, working with ASP web services, debugging web applications, creating mobile web applications. Pass/No Pass/Letter Grade Option. \$3.00 Material Fee — Payable at Registration. (CSU)

CIS 226 C Java Programming 3 Units

Prerequisite: CIS 211 C.

Term hours: 48–54 lecture and 32–36 laboratory TBA. This course introduces students to the Java programming language. Students will learn the language syntax, how to design and debug programs, and how to use Java programs with HTML pages. \$3.00 Material Fee — Payable at Registration. (UC/CSU)

CIS 227 C Java Script Programming and AJAX 3 Units

Advisory: CIS 179 C or Consent of Instructor.

Term hours: 48–54 lecture and 16–18 laboratory. This course teaches the students to use the JavaScript programming languages to enhance Web pages. Emphasis is placed on creating HTML pages that include JavaScript programs. The student will learn the basic syntax of the JavaScript language, how to create JavaScript programs inside HTML documents, and how to use JavaScript programs to enhance Web pages. In addition, the application of AJAX Web programming language will be discussed. Pass/No Pass/Letter Grade Option. \$3.00 Material Fee — Payable at Registration. (CSU)

CIS 229 C Introduction to XML Programming 3 Units

Term hours: 48–54 lecture and 16–18 laboratory. This is a class in Web documents management. The course is ideal for students interested in next-generation Web publishing who want to gain a working knowledge of XML and use it to build a wide range of dynamic effects and compelling Web applications from formatting and managing documents to E-commerce and searching and managing data. In this class, students will master the fundamentals of XML, including XSL (Extensible Stylesheet Language), DTDs (Document Type Definitions), CSS (Cascading Style Sheets) and XML schemas. This course is designed for those with experience in creating Web pages and who have some knowledge of style sheets. Pass/No Pass/Letter Grade Option. \$3.00 Material Fee — Payable at Registration. (CSU)

CIS 230 C Cisco Networking 1 3 Units

Term hours: 32–36 lecture and 48–54 laboratory. This course focuses on network terminology and protocols, Local Area Networks (LANs), Wide Area Networks (WANs), Open System Interconnection (OSI) model, cabling, cabling tools, routers, router programming, Ethernet, Internet Protocol (IP) addressing, and network standards. This course is offered through Cisco Local Academy and upon successful course completion students will receive a certificate from Cisco. \$3.00 Material Fee — Payable at Registration. (CSU)

CIS 231 C Cisco Networking 2 3 Units

Prerequisite: CIS 230 C.

Term hours: 32–36 lecture and 48–54 laboratory. This course introduces students to router fundamentals, router setup and configuration, network management, routing and routed protocols, and network troubleshooting. Topics include: managing Cisco IOS software, Distance Vector Routing Protocols, TCP/IP suite error and control messages, basic router troubleshooting, and access control lists. This course is offered through Cisco Local Academy and upon successful course completion students will receive a certificate from Cisco. \$3.00 Material Fee — Payable at Registration. (CSU)

CIS 232 C Cisco Networking 3 3 Units

Prerequisite: CIS 231 C.

Term hours: 32–36 lecture and 48–54 laboratory. This course focuses on advanced IP addressing techniques; Variable Length Subnet Masking (VLSM), intermediate routing protocols (RIP v2, single-area OSPF, EIGRP), command-line interface configuration of switches, Ethernet switching, Virtual LANs (VLANs), Spanning Tree Protocol (STP) and VLAN Trunking Protocol (VTP). This course is offered through Cisco Local Academy and upon successful course completion students will receive a certificate from Cisco. \$3.00 Material Fee — Payable at Registration. (CSU)

CIS 233 C Cisco Networking 4 3 Units

Prerequisite: CIS 232 C.

Term hours: 32–36 lecture and 48–54 laboratory. This course focuses on advanced IP addressing techniques; Network Address Translation (NAT), Port Address Translation (PAT), and DHCP; WAN technology and terminology; PPP, ISDN, DDR, Frame Relay, network management, and introduction to optical networking. This course is offered through Cisco Local Academy and upon successful course completion students will receive a certificate from Cisco. \$3.00 Material Fee — Payable at Registration. (CSU)

CIS 234 C Advanced Java Programming 3 Units*Prerequisite: CIS 226 C.*

Term hours: 48–54 lecture and 32–36 laboratory TBA. This course covers advanced topics in Java programming. Topics include graphics, animation, GUI components, exception handling, files and streams, and data structures. \$3.00 Material Fee — Payable at Registration. (CSU/UC)

CIS 236 C Introduction to Oracle: SQL and PL/SQL 3 Units

Term hours: 32–36 lecture and 48–54 laboratory. This course offers students an extensive introduction to data server technology. The class covers the concepts of both relational and object relational databases and the powerful SQL (Structured Query Language) and PL/SQL (Programming Language/Structured Query Language) programming languages. Students are taught to create and maintain database objects and to store, retrieve, and manipulate data. In addition, students learn to create PL/SQL blocks of application code that can be shared by multiple forms, reports, and data management applications. Demonstrations and hands-on practice reinforce the fundamental concepts. \$3.00 Material Fee — Payable at Registration. (CSU)

CIS 237 C Oracle: Architecture and Admin 3 Units*Prerequisite: CIS 236 C.*

Term hours: 32–36 lecture and 48–54 laboratory. This course is designed to give the students a firm foundation in basic administrative tasks and provide the necessary knowledge and skills to set up, maintain, and troubleshoot an Oracle database. The student learns to use an administration tool to start up and shut down a database, create a database, manage file and database storage, and manage users and their privileges. In addition, the student learns to organize the database and to move data into and between databases, under different environments. \$3.00 Material Fee — Payable at Registration. (CSU)

CIS 238 C Oracle: Backup and Recovery 3 Units*Prerequisite: CIS 237 C.*

Term hours: 32–36 lecture and 48–54 laboratory. This course introduces the students to the critical task of planning and implementing database backup and recovery strategies. The class addresses backup and recovery techniques and examines various backup, failure, restore, and recovery scenarios. In the hands-on exercises, students examine backup methodologies based on business requirements in a mission critical enterprise. Students utilize multiple strategies and Oracle tools such as Recovery Manager to perform backup, restore, and recovery operations. \$3.00 Material Fee — Payable at Registration. (CSU)

CIS 239 C CCNA Bootcamp 3 Units

Term hours: 48–54 lecture and 16–18 laboratory. Three hours lecture and two hours laboratory TBA per week. The Cisco networking courses will be reviewed to prepare for the CCNA exam. Topics include IP addressing and subnetting, router and switch configurations, LAN and WAN protocols, and sample exam questions. \$3.00 Materials Fee — Payable at Registration. (CSU)

CIS 240 C Cisco Wireless Networking 3 Units

Term hours: 48–54 lecture and 16–18 laboratory. This course focuses on the design, installation, configuration, operation, and troubleshooting of enterprise-level Wireless Local Area Networks (WLANs). A comprehensive overview of wireless technologies, devices, security, design, and best practices with a particular emphasis on real world applications and skills is covered. Pass/No Pass/Letter Grade Option. \$3.00 Material Fee — Payable at Registration. (CSU)

CIS 241 C Spreadsheet — Advanced MS Excel 3 Units*Prerequisite: CIS 132 C.*

Term hours: 48–54 lecture and 16–18 laboratory. This course is designed to introduce students to the use of advanced spreadsheet tools in the solution of problems. Students will use Visual Basic to develop Excel applications. \$3.00 Material Fee — Payable at Registration. (CSU)

CIS 242 C Database — Advanced MS Access 3 Units*Prerequisite: CIS 142 C.*

Term hours: 48–54 lecture and 32–36 laboratory TBA. This course teaches advanced topics in Microsoft Access. Students will learn how to design and implement complex databases; how to use Structured Query Language; and how to create complex queries, complex forms, and complex reports. Other topics include how to write Microsoft Access programs using Visual Basic and how to use Access with other applications. \$3.00 Material Fee — Payable at Registration. (CSU)

CIS 243 C Oracle Forms and Reports 3 Units

Term hours: 32–36 lecture and 48–54 laboratory. This course provides coverage of Oracle database applications development, including client/server database architecture, SQL commands, PL/SQL programs, Forms Builder and Report Builder. Discussions will include new technologies, such as the new browser interface for the Enterprise Manager and SQL. \$3.00 Material Fee — Payable at Registration. (CSU)

CIS 244 C Java Game Programming 3 Units

Term hours: 48–54 lecture and 16–18 laboratory. This course covers game programming for Java developers. It leads students to create desktop and Internet computer games using the latest Java programming language techniques. \$3.00 Material Fee — Payable at Registration. (CSU)

CIS 245 C Perl Programming 3 Units

Term hours: 48–54 lecture and 16–18 laboratory TBA. This hands-on course introduces students to the Perl and CGI programming language. Topics include syntax, basic scripting skills, arrays and hashes, I/O, regular expressions, and subroutines. The course also introduces object-oriented programming in Perl, as well as CGI.pm module and Perl web programming. Pass/No Pass/Letter Grade Option. \$3.00 Material Fee — Payable at Registration. (CSU)

CIS 246 C PHP Programming 3 Units

Term hours: 48–54 lecture and 16–18 laboratory TBA. This hands-on course introduces students to the PHP programming language. Topics include basic PHP programming skills, and integration with HTML. It also explores advanced modules including accessing the MySQL database. Students will learn to develop dynamic web content and data-driven web sites using PHP. Pass/No Pass/Letter Grade Option. \$3.00 Material Fee — Payable at Registration. (CSU)

CIS 247 C Python Programming 3 Units

Term hours: 48–54 lecture and 16–18 laboratory TBA. In this class students will obtain a hands-on introduction to the Python language, Python tools, Python applications, and Python Web programming. Through lectures and laboratory work, students learn the skills of Python programming. Pass/No Pass/Letter Grade Option. \$3.00 Material Fee — Payable at Registration. (CSU)

CIS 248 C Voice Over IP 3 Units

Term hours: 48–54 lecture and 16–18 laboratory. This course focuses on the design, configuration, troubleshooting and operation of IP (Internet Protocol) telephony technology to exchange voice. A comprehensive overview of packet telephony technologies including signaling, call control and voice quality with a particular emphasis on real world applications and skills is covered. Pass/No Pass/Letter Grade Option. \$3.00 Material Fee — Payable at Registration. (CSU)

CIS 250 C Word Processing 1 to 4 Units

Term hours: 16–72 lecture and 48–216 laboratory TBA. This variable unit, open entry/open exit course with flexible hours consists of basic and advanced text editing performed using Microsoft Word. Unit credit may range from 1 to 4 units in any given semester. Units may be increased or decreased no later than the withdrawal deadline of the course. Only upon successful completion of the first unit of instruction will the student be eligible for the second unit of credit for the semester. Knowledge of keyboarding is recommended. Open Entry/Open Exit. May be taken for a cumulative total of 4 units. Pass/No Pass/Letter Grade Option. \$3.00 Material Fee — Payable at Registration. (CSU)

CIS 251 C Advanced Word Processing 1 to 4 Units

Prerequisite: Two units of CIS 250 C.

Term hours: 16–72 lecture and 48–216 laboratory TBA. This variable unit, open entry/open exit course with flexible hours is designed as a continuation of CIS 250 C. Advanced applications include, but are not limited to, desktop publishing, macros, margins, and record processing. Unit credit may range from 1 to 4 units in any given semester. Units may be increased or decreased no later than the withdrawal deadline of the course. Only upon successful completion of the first unit of instruction will the student be eligible for the second unit of credit for the semester. May be taken for a cumulative total of 4 units. Open Entry/Open Exit. Pass/No Pass/Letter Grade Option. \$3.00 Material Fee — Payable at Registration. (CSU)

CIS 252 C Java Web Applications 3 Units

Prerequisite: CIS 226 C.

Term hours: 48–54 laboratory and 32–36 laboratory TBA. This course covers topics in Java Web Applications. Topics include multithreading, networking, JDBC, Servlet, JSP, JSF, and web services. \$3.00 Material Fee — Payable at Registration. (CSU)

CIS 253 C Oracle PL/SQL Programming 3 Units

Term hours: 48–54 lecture and 16–18 laboratory. This course introduces students to the essential concepts and techniques needed to build web application on Oracle Application Server. Students will learn to create PL/SQL applications that access Oracle database but deliver outputs in HTML format. \$3.00 Material Fee — Payable at Registration. (CSU)

CIS 258 C CCNA Security 3 Units

Term hours: 32–36 lecture and 48–54 laboratory. CCNA Security equips students with the knowledge and skills needed to prepare for entry-level security specialist careers. Topics covered include: implementing AAA on network devices, implementing Cisco IOS firewall and IPS feature sets, implementing site-to-site IPsec VPNs, and administering effective security policies. This course is offered through Cisco Local Academy and upon successful course completion students will receive a certificate from Cisco. Pass/No Pass/Letter Grade Option. \$3.00 Material Fee — Payable at Registration. (CSU)

CIS 260 C Game Concepts Development 3 Units

Term hours: 48–54 laboratory and 32–36 laboratory TBA. In this course students will study the technology, structure, hardware, software, graphics and art, sound effects, simulation engines, and job market trends involved in the construction of computer games. Students will learn how to plan and develop outlines for their own games. The course will emphasize hands-on exercises in creation of games using game generator software. Pass/No Pass/Letter Grade Option. \$3.00 Material Fee — Payable at Registration. (CSU)

CIS 261 C Game Programming 3 Units

Term hours: 48–54 lecture and 16–18 laboratory TBA. This course introduces students to basic game programming concepts and program design process. Topics include game terminology, genre analysis, platform comparisons, and content creation. Students will also explore major game programming languages. Pass/No Pass/Letter Grade Option. \$3.00 Materials Fee — Payable at Registration. (CSU)

CIS 262 C New Technology 3 Units

Term hours: 48–54 lecture and 16–18 laboratory. This hands-on class is designed to teach students to acquire the necessary technical skills in the use of the latest technology. Emphasis is placed on the current and future trends of information technology in today's computer industry. The topics discussed will include, but are not limited to, the Internet technology and applications, networking and wireless technology, Web technology, mobile and hand-held computing, storage technology, robotics applications, and artificial intelligence. Pass/No Pass/Letter Grade Option. \$3.00 Material Fee — Payable at Registration. (CSU)

CIS 263 C Mobile Game Programming 3 Units

Term hours: 48–54 lecture and 32–36 laboratory TBA. This course offers an overview of the gaming products for platforms involving anything handheld, including cell phones, PDAs and Pocket PCs. Students will learn to develop mobile games for the portable platforms of their choices. Pass/No Pass/Letter Grade Option. \$3.00 Materials Fee — Payable at Registration. (CSU)

CIS 264 C Windows Game Programming 3 Units

Term hours: 48–54 lecture and 16–18 laboratory TBA. This course leads students to develop skills and techniques relevant to the programming of computer games for Windows. The course will focus primarily on programming aspects. Pass/No Pass/Letter Grade Option. \$3.00 Material Fee — Payable at Registration. (CSU)

CIS 265 C 3D Game Programming 3 Units

Term hours: 48–54 lecture and 16–18 laboratory TBA. This course uses open source tools to introduce programming skills and techniques for creating interactive 3D games. The course will focus primarily on programming aspects. Pass/No Pass/Letter Grade Option. \$3.00 Material Fee — Payable at Registration. (CSU)

CIS 266 C Game Programming in Flash 3 Units

Term hours: 48–54 lecture and 16–18 laboratory. This course teaches students how to use Macromedia Flash to create games. Topics include a review of basic Flash concepts, basic Action Script programming, creating Flash 3D effects, using physics and motion in a game, including sound in a game, and creating the overall game design structure. Pass/No Pass/Letter Grade Option. \$3.00 Material Fee — Payable at Registration. (CSU)

CIS 274 C Project Management Fundamentals 3 Units

Term hours: 48–54 laboratory and 32–36 laboratory. This course teaches the basics of project management and includes preparation for the Project Management Professional certification exam. Topics include integration, scope, time, cost, quality, human resource management, communications, risk, and procurement management. Pass/No Pass/Letter Grade Option. \$3.00 Materials Fee — Payable at Registration. (CSU)

CIS 276 C Computer Forensics I 3 Units

Term hours: 48–54 lecture and 16–18 laboratory TBA. This course introduces basic techniques and methods used for collecting and preserving digital evidences for computer forensic process. This course emphasizes on gathering digital evidences from a computer system. Pass/No Pass/Letter Grade Option. \$3.00 Material Fee — Payable at Registration. (CSU)

CIS 277 C Computer Forensics II**3 Units**

Term hours: 48–54 lecture and 16–18 laboratory. This course equips students with professional knowledge and techniques to investigate, preserve, process, report, and present digital evidence. Pass/No Pass/Letter Grade Option. \$3.00 Material Fee — Payable at Registration. (CSU)

CIS 278 C Cyber Crime**3 Units**

Term hours: 48–54 lecture and 16–18 laboratory. This course will introduce the student to concepts and actions involved with cybercrime. The emphasis of the course will be placed on the student gaining an understanding of the types, the elements, and the corresponding forensic evidence that exists from cybercrime. Pass/No Pass/Letter Grade Option. \$3.00 Material Fee — Payable at Registration. (CSU)

CIS 279 C Comp Forensics Legal Aspects**3 Units**

Term hours: 48–54 lecture and 16–18 laboratory. This course will examine the civil and criminal aspects of computer forensics. Students will be introduced to case law and will learn appropriate steps, procedures, and techniques to comply with law when conducting forensic examinations. Also, testimony concepts by the forensic examiner will be discussed. Pass/No Pass/Letter Grade Option. \$3.00 Material Fee — Payable at Registration. (CSU)

CIS 280 C Analysis of Digital Media**3 Units**

Term hours: 48–54 lecture and 16–18 laboratory. This course will provide the student with the concepts and skills to complete examinations on alternative digital media. This includes an understanding of the various file systems, acquisition procedures, recovery methods, and reporting on findings. Pass/No Pass/Letter Grade Option. \$3.00 Material Fee — Payable at Registration. (CSU)

CIS 281 C Computer Forensics Capstone**3 Units**

Prerequisite: CIS 280 C with a minimum grade of "C."

Term hours: 48–54 lecture and 16–18 laboratory. This course will complete the computer forensics certificate program with a thorough testing process of the student's knowledge of computer forensics. Through a series of examinations, students will demonstrate their knowledge of appropriate computer forensic procedures/protocol, acquisition techniques, file systems, analysis of files, alternative media, Internet history/email analysis, log analysis, reporting, incorporating all knowledge gained through the courses. \$3.00 Material Fee — Payable at Registration. (CSU)

CIS 295 C CIS Internship**1 to 4 Units**

Term hours: 16–18 lecture and 54–240 laboratory depending on units attempted. This course is designed to give the student credit for work experience at a related occupational worksite, while being concurrently enrolled in a vocational major. For each unit of credit, a minimum of 75 paid or 60 unpaid worksite internship hours is required. The internship allows students to apply knowledge gained in college courses to an actual work setting, sample career choices and improve job-readiness skills. Supplemental reading and course assignments required. Variable Unit Class. May be taken for credit 4 times. Open Entry/Open Exit. Pass/No Pass/Letter Grade Option. (CSU)

CIS 298 C Computer Information Systems**Seminar****.5 to 12 Units**

Prerequisite: May be required.

Corequisite: May be required.

Advisory: May be required.

Term hours: 0–216 lecture and 0–648 laboratory. This course will utilize a lecture and/or lab approach for students enrolled in the Computer Information Systems Program to increase their knowledge in applied areas. Topics will be offered to increase the student's knowledge of the computer information systems profession by updating content on recent changes and requirements and by preparing for new trends in Computer Information Systems. May be taken for credit 1–4 times. Pass/No Pass or Pass/No Pass/Letter Grade Option or Standard Letter Grade. Fee may be required — Payable at Registration. (CSU)

CIS 299 C CIS Independent Study**.5 to 2 Units**

Prerequisite: Approved Independent Study Learning Contract.

Term hours: 8–36 hours lecture depending on units attempted. This course is designed for students who wish to gain further experience, knowledge, or expertise beyond their current offerings in their area of study. The number of class hours or activities per week will be determined by the scope of the topic. The instructor will devise learning strategies to be followed by the student. Students must obtain permission from the program coordinator to be enrolled in this class. May be taken for credit 4 times. (CSU)

Computer Science

Division of Science/Engineering/Mathematics

Division Dean — Richard Fee

Counselor

Deidre Porter

COMPUTER SCIENCE TRANSFER PROGRAM

Students should consult a counselor or www.assist.org for lower division major requirements for most California public universities. (See the Standard Definitions section of the catalog for a description of ASSIST.) Students transferring to an independent college/university should consult the catalog of the individual school and a counselor for lower division major requirements.

Computer Science (CSCI)

CSCI 123 C Introduction to Programming Concepts**in C++****4 Units**

Prerequisite: MATH 141 C or MATH 142 C with minimum grades of "C."

Term hours: 64–72 lecture and 16–18 laboratory. This course is an introduction to the basic principles of programming using C++ as the development tool. Topics include the structure and design of algorithms, input/output, branching structures, functions, recursion, built-in data types, arrays, structures, files, pointers and elementary operations on linked structures. The object-oriented programming paradigm will be introduced. Topics include encapsulation, polymorphism, libraries, streams, inheritance and abstract data types. Students will design algorithms, write external and internal documentation and design and write source code in C++. (UC/CSU)

CSCI 133 C Data Structures in C++**4 Units***Prerequisite: CSCI 123 C with a grade of "C" or better.*

Term hours: 64–72 lecture and 16–18 laboratory TBA. This is a course in algorithm design and data structures implemented using C++. Data structures examined are arrays, linked lists, stacks, queues, trees, tables, and graphs. Algorithm topics include hashing, sorting heaps, searches and algorithm efficiency using Big-O notation. Students will create and modify class libraries to implement these structures. (UC/CSU)

CSCI 205 C Fortran Programming**3 Units***Prerequisite: MATH 142 C, or MATH 130 C, or three and one-half years of high school college preparatory mathematics.*

Term hours: 48–54 lecture and 16–18 laboratory TBA. This is a course for science, engineering, and mathematics students to acquaint them with the use of digital computers and to enable them to write programs in the FORTRAN language. Elementary numerical methods, algorithms, flow-charting, and program documentation are included. (UC/CSU, CSU GE)

CSCI 298 C Computer Science Seminar**.5 to 12 Units***Prerequisite: May be required.**Corequisite: May be required.**Advisory: May be required.*

Term hours: 0–216 lecture and 0–648 laboratory. This is a lecture/discussion approach to special topics involving computer science. It may be a problem session related to a particular course in the curriculum, or a study of topics not ordinarily covered within the curriculum. Consult the class schedule to verify unit credit for a particular semester. May be taken for credit 1–4 times. Pass/No Pass or Pass/No Pass/Letter Grade Option or Standard Letter Grade. Fees may be required — Payable at Registration. (UC Credit Limitation/CSU)

CSCI 299 C Computer Science**Independent Study****.5 to 2 Units***Prerequisite: Approved Independent Study Learning Contract.*

Variable Unit Class. May be taken for credit 4 times. Six hours assigned independent study or research per week for maximum credit. This course is for students who have demonstrated interest and capability for increased knowledge of computer science topics not ordinarily covered in the curriculum. Students will participate in independent study or research on assigned projects under faculty supervision. (UC Credit Limitation/CSU)

Continuing Education Program

The Division of Health Science offers courses through extended day sessions at Cypress College and through the Adult Continuing Education Department of the North Orange County Community College District. Continuing education courses are designed for programs within the Health Science Division.

General inquiries and application to programs may be obtained from the Health Science Counseling Office at (714) 484-7270. The classes offered are approved by the California Board of Regional Nursing (Provider Number 00110), for the number of hours the class meets. Request list of approved classes from the Health Science Division.

Counseling and Student Development

Division of Counseling

Division Dean — Paul R. de Dios*Director, DSP&S* — Kimberly K. Bartlett*Manager, International Student Program* — Yongmi Han*Manager, Matriculation* — Kristine Nelson*Articulation Officer* — Stacey Howard*Faculty — Counselors*

Dana Bedard

dbedard@CypressCollege.edu

Kelly Carter

kcarter@CypressCollege.edu

Penny Gabourie

pgabourie@CypressCollege.edu

Robert Grantham

rgrantham@CypressCollege.edu

Jane Jepson

jjepson@CypressCollege.edu

Renay Laguana-Ferinac

rlaguana@CypressCollege.edu

Velia Lawson

vlawson@CypressCollege.edu

Deborah Michelle

dmichelle@CypressCollege.edu

Therese Mosqueda-Ponce

tmponce@CypressCollege.edu

Daniel Pelletier

dpelletier@CypressCollege.edu

Deidre Porter

dporter@CypressCollege.edu

Renee Ssensalo

rssensalo@CypressCollege.edu

Denise Vo

dvo@CypressCollege.edu

During the summer months, counselors can be reached by email at onlinecounselor@CypressCollege.edu.

PROGRAM LEARNING OUTCOMES (PLOs)

The courses taught by this department contribute to the General Education and Basic Skills Program Learning Outcomes. Please refer to General Education and Basic Skills Program Learning Outcomes.

Counseling and Student Development (COUN)

COUN 040 C College Readiness**.5 Units**

Term hours: 8–9 lecture. This course is designed to prepare students for their first college semester by satisfying the California community colleges' matriculation requirements of assessment, orientation, and counseling/advising. Non-Degree Credit. Pass/No Pass only.

COUN 060 C Academic Success and College Survival**1 Unit**

Term hours: 8–9 lecture. This course is designed to help students who are experiencing difficulties in succeeding in college. Students will learn skills such as time management, decision-making, and study skills which will enable them to identify and overcome educational difficulties. Pass/No Pass only.

COUN 071 C Career Prep and Life Management**3 Units**

Term hours: 48–54 lecture. This course is designed for students needing special assistance in career planning, job search techniques, personal adjustment, life management. Emphasis will be placed on discovering individual areas of strength which will enable students to focus on possibilities for success. Non-Degree Credit. Pass/No Pass/Letter Grade Option.

COUN 072 C Learning Assessment .5 Units*Prerequisite: Learning Disability Specialist Approval.*

Term hours: 8–9 lecture. Intensive diagnostic learning assessment for students with learning disabilities whose learning disabilities have impeded academic performance. Emphasis is on assessing specific academic and learning modality strengths and weaknesses. Development of an individual education plan (IEP) outlining long term goals/short term objectives for identified eligible students with learning disabilities. Non-Degree Credit. Open Entry/Open Exit. Pass/No Pass only.

COUN 073 C Computer Access I 3 Units

Term hours: 32–36 lecture and 48–54 laboratory. This course is designed for students with verified disabilities. This course provides training in the use of assistive technology which enhances the ability of students with disabilities to access and use personal computers. The course will cover word processing and an introduction to the Internet. May be taken for credit 2 times. Pass/No Pass/Letter Grade Option.

COUN 074 C Computer Access II 3 Units*Prerequisite: COUN 073 C.*

Term hours: 32–36 lecture and 48–54 laboratory. This course is designed for, but not limited to, students with verified disabilities. This course provides training in intermediate computer concepts using prescribed assistive technology. The course will also cover intermediate to advanced Internet skills. Students will enhance computer access skills through completion of assigned projects in a variety of formats (word processing, spreadsheets, presentations, and publications). May be taken for credit 2 times. Pass/No Pass/Letter Grade Option.

COUN 100 C College Orientation 3 Units*Prerequisite: Entry in Special Assistance Program-Disabled Student Programs and Services.*

Term hours: 48–54 lecture. This course is designed for students with Learning Disabilities and will introduce college support services, provide vocational and educational planning (SEC), given an orientation into college life and raise student awareness of the importance of self-motivation and perseverance in the pursuit of personal goals. Students will learn campus policies and procedures, strengthen study skills and develop responsible academic and personal attitudes for student success. Pass/No Pass/Letter Grade Option. (CSU)

COUN 105 C Stress Management 1 Unit

Term hours: 8–9 lecture. This course is designed to increase the student's awareness of the effects of stress on academic performance and daily life. Emphasis will be placed on understanding effective and ineffective responses to stress and on planning a personal stress management program. Students will explore and practice a variety of practical stress management techniques. May be taken for credit 2 times. Pass/No Pass only. \$3.00 Material Fee — Payable at Registration. (CSU, CSU GE)

COUN 110 C Teaching as a Career 3 Units

Term hours: 32–36 lecture and 48–54 laboratory TBA. This course is designed as an introduction to the teaching profession where students will examine concepts and issues related to education in a democratic society within historical, social, philosophical, legal and political contexts. Students will develop personal knowledge and understanding of (1) the competing purpose and values of schools in society, (2) the nature of teaching and the teaching profession, (3) the impact of local, state, and federal government policies on schools, and (4) contemporary educational issues. Course content and assignments will be related to a 45 hour fieldwork experience in an educational setting. Pass/No Pass/Letter Grade Option. (UC/CSU)

COUN 135 C Leadership 3 Units

Term hours: 48–54 lecture. This course includes the study and practical application of group and individual leadership techniques. It is designed to improve awareness of group dynamics, listening skills, personal values, decision-making, problem solving and organizational development. Duplicate credit not granted for COUN 135HC. (UC/CSU)

COUN 135HC Honors Leadership 3 Units

Term hours: 48–54 lecture. This course is designed for Honors students and requires leadership participation in a campus or community organization. It includes the study and practical application of group and individual leadership techniques. It is designed to improve awareness of group dynamics, listening skills, personal values, decision-making, problem solving and organizational development. It emphasizes critical analysis of leaders in the news, history or literature. Duplicate credit not granted for COUN 135 C. (UC/CSU)

COUN 140 C Educational Planning .5 Units

Term hours: 8–9 lecture. This course is required the first semester of attendance as part of the matriculation process for all new students who are taking more than two classes or who plan to earn the Associate Degree, obtain a Certificate, or transfer to a four year college. The course includes orientation to college life and responsibilities, college requirements and regulations, career guidance, and development of a personal educational plan. Duplicate credit not granted for COUN 140HC. \$6.00 Materials Fee — Payable at Registration. Pass/No Pass only. (CSU)

COUN 141 C Career Exploration 1 Unit

Term hours: 16–18 lecture. This class is designed for students who are undecided about their educational or career goals. Using a career planning process, students assess interests, skills, personality, values, life and work style choices. Students explore cultural differences and gain an awareness which is applied to the work setting. Students research potential educational and career goals; apply decision making tools, and relate their self-assessment information to occupational possibilities and college majors. Pass/No Pass only. \$6.00 Material Fee — Payable at Registration. (CSU, CSU GE)

COUN 144 C Women and Careers 2 Units

Term hours: 32–36 lecture. This course is designed to help women expand their self-image by providing personal exploration through career assessment, values clarification and skills analysis. The course provides creative job search techniques and resume writing, interviewing skills, decision-making, goal setting, as well as an "Informational Interview Project and a Portfolio. Pass/No Pass only. \$6.00 Material Fee — Payable at Registration. (CSU, CSU GE)

COUN 145 C Adult Career/Life Transitions 2 Units

Term hours: 32–36 lecture. Course is designed to assist adults in management of the multitude of transitions experienced in mid-life, primarily that of career changes, whether by choice, economic forces, or other personal circumstances. Assessment of strengths, interests, skills, values and personality type support targeted career research, creative job search techniques and resume writing. Decision making and goal setting, as well as typical adult development issues (mental, financial, relational, spiritual, and aging) are addressed to assist in the transition to new and more meaningful employment. (CSU, CSU GE)

COUN 146 C Decision Making 1 Unit

Term hours: 16–18 lecture. This course is designed to teach students decision-making concepts and skills for application in career planning, educational planning, and everyday life. Emphasis will be placed on practicing decision-making through class discussions, role-playing, and simulation. Pass/No Pass/Letter Grade Option. (CSU, CSU GE)

COUN 147 C Peer Advising 1 Unit

Term hours: 18 lecture. This course is designed to provide skills in specific peer advisement situations, observations, and communications. Training in active listening, group processes, and role-playing are emphasized. May be taken for credit 2 times. Pass/No Pass only. (CSU)

COUN 148 C Human Potential 1 Unit

Term hours: 18 lecture. This experiential course enables students to examine and assess their strengths, values, decision-making skills and potential in order to plan realistic educational goals. Pass/No Pass/Letter Grade Option. (CSU)

COUN 150 C Academic and Life Success 3 Units

Term hours: 48–54 lecture. This course will provide students with knowledge, information, and practical skills to better understand themselves as students, people and members of society. It will assist them in achieving academic, and life goals and to develop plans and strategies to successfully meet those goals. (CSU, CSU GE)

COUN 151 C Career/Life Planning 3 Units

Term hours: 48–54 lecture and 3 laboratory. A complete class in career/life planning, including introduction to the tools for dealing with change; an analysis of desired lifestyles; self-assessment; overcoming obstacles, and analysis of work, its organizations, and where you want to work; decision-making, people, environments, career-researching and job-finding, resumes, interviewing, and goal setting. \$3.00 Material Fee — Payable at Registration. (CSU, CSU GE)

COUN 156 C Self-Concept 1 Unit

Term hours: 16–18 lecture. This course introduces the student to the self-concept and assists students in acquiring the psychological characteristics necessary to meet daily challenges. Emphasis is on the enhancement of academic performance and success as a result of developing a stronger self-concept. Pass/No Pass/Letter Grade Option. (CSU)

COUN 160 C College/University Transition 1 Unit

Term hours: 16–18 lecture. This course is designed for student and the parents of students who plan to transfer to a college or university. Topics include the value of pursuing higher education, selection of a transfer institution, admissions, academic requirements, financial aid options, special programs, priority filing deadline, and developing an autobiographical essay. Duplicate credit not granted for COUN 160HC. Pass/No Pass/Letter Grade Option. (CSU)

COUN 160HC Honors University Transition 1 Unit

Term hours: 16–18 lecture. COUN 160HC is required during the first semester of attendance as part of the matriculation process for Honors Program students. The course is an enhanced orientation to the transfer process. Topics include the value of pursuing higher education, selection of a transfer institution, admission, academic requirements, financial aid options, special programs, priority filing deadlines, developing an autobiographical essay and personal portfolio. Emphasis will be placed on researching and evaluating transfer options. Duplicate credit not granted for COUN 160 C. Pass/No Pass/Letter Grade Option. (CSU)

COUN 298 C Counseling/Guidance Seminar .5 to 12 Units

Prerequisite: May be required.

Corequisite: May be required.

Advisory: May be required.

Term hours: 0–216 lecture and/or 0–648 laboratory depending on units attempted. Various classes may be offered which are designed to meet the interests and needs of the students and faculty. May be taken for credit 1–4 times. Pass/No Pass or Pass/No Pass/Letter Grade Option or Standard Letter Grade. Fees may be required — Payable at Registration. (CSU)

COUN 299 C Counseling — Independent Study .5 to 2 Units

Prerequisite: Approved Independent Study Learning Contract.

Term hours: Hours vary according to units assigned. This course is designed for students who wish to explore in-depth various guidance-related topics. Students develop an Independent Study Learning Contract with the instructor that details the objectives and course content and scope to be completed by the student. Consult class schedule to verify credit for a particular term. May be taken for credit 4 times. Open Entry/Open Exit. Pass/No Pass only. (CSU)

Court Reporting

Division of Business and Computer Information Systems

Division Dean — Dave Wassenaar

Faculty

Carolee Freer

Counselor

Robert Grantham

PROGRAM LEARNING OUTCOMES (PLOs)

Court Reporting

A student who completes the Court Reporting field of study will be able to:

1. Students will be able to transcribe documents at a professional level.
2. Students will have the ability to apply the rules of grammar, spelling, punctuation, and capitalization to sentences, paragraphs, testimony, and jury charge through a systematic series of programmed (takes) testing and other projects.
3. Students will be able to demonstrate an understanding and application of California and United States criminal and civil law, along with a basic knowledge of related areas of law and legal terminology.
4. Students will be able to demonstrate an understanding and application of anatomy, physiology, and/or medical terminology.
5. Students will be able to assume the role of the real-time reporter through simulated trials and depositions to perform various functions.
6. Students will be able to produce a complete and accurate transcript of at least ten pages from steno notes, using computer-aided transcription.
7. Students will be able to fulfill the state required internship hours and submit a written narration of their experiences, either in transcript format or in report format. Students will submit a timesheet signed by the supervising reporter in the field verifying hours completed.
8. Students will be able to understand and apply knowledge of basic vocabulary to a variety of reporting situations.
9. Students will be able to understand and follow the California codes as they apply to reporting situations.
10. Students will be able to demonstrate knowledge of court and deposition procedures, along with an understanding of court structure, both state and Federal.
11. Students will be able to prepare an 18,000 word steno dictionary using computer software with applications for the completion of transcripts and other documents.

12. Students will be familiar with the California Court Reporters Code of Ethics and the National Court Reporters Association Code of Ethics and be able to apply these standards, rules, and regulations in the preparation of documents and in reporting situations.

**ASSOCIATE IN SCIENCE DEGREE
COURT REPORTING Program Code: 1S07819**

Preparation for State Certificate Examination

The courses listed meet the requirements of the Court Reporter’s Board for an Associate Degree at Cypress College. This program was accredited by the CR Board on March 7, 1978. Academic courses completed in Adult Education or a private Court Reporting School are not transferable.

To earn an Associate Degree students must complete: (1) all major course requirements with a minimum grade of “C”; (2) 25 units of General Education Graduation Requirements; (3) any elective courses to complete a minimum of 60 units; and, (4) with an overall GPA of 2.0. At least 50% of all major course work must be completed at Cypress College.

Courses that fulfill major requirements for an Associate Degree at Cypress College might not be the same as those required for completing the major at a transfer institution offering a Baccalaureate Degree. For information on specific university requirements, please consult with your counselor, or visit the Transfer Center.

**STUDENTS MUST FURNISH
THEIR OWN MACHINE AND PAPER**

Required Courses are listed in suggested sequence:

Course #	Title	Units
SEMESTER 1		
CTRP 040 C	Beg. Machine Shorthand Theory	3
CTRP 041 C	Court Reporting Theory Review	3
CTRP 071 C	Legal Terminology and Rhetoric	3
MGT 055 C	Business English	3
CTRP 067 C	Basic Vocabulary Development	2
COUN 140 C	Educational Planning	.5
Total Units Required		14.5
SEMESTER 2		
CTRP 042 C, 043 C	Machine Shorthand Speed Bldg 1 and 2	4
CTRP 051 C	Court/Conference Reporting: Legal	3
CTRP 073AC	Spelling for Modern Business	1
CTRP 073BC	Punctuation — Court Reporting	1
HS 145 C	Survey of Medical Terminology	3
*ENGL 106 C	Critical Thinking	3
MGT 041 C	Survey of Business Law	3
	or	
MGT 240 C	Legal Environment of Business	(3)
	or	
MGT 241 C	Legal Aspects — Business Transactions	(3)
	or	
MGT 141 C	Personal Law	(3)
*SOSC	Social Science Elective	3
Total Units Required		21
SUMMER SESSION		
CTRP 044 C, 045 C	Machine Shorthand Speed Bldg 3 and 4	4

SEMESTER 3		
CTRP 057 C	Mach. Shorthand Challenge — 160	2
CTRP 046 C	Machine Shorthand Speed Bldg 5	2
CTRP 052 C	Court/Conference Reporting: Medical	3
MGT 242 C	American Judicial System	4
CTRP 066 C	Machine Transcription — Medical	2
	*Humanities Elective	3
	*Physical Education Elective	1
CTRP 054 C	Two/Four Voice Testimony	3
CTRP 082 C	Computer Aided Transcription: ProCAT	1
	or	
CTRP 083 C	Computer Aided Transcription: Stenograph	(1)
	or	
CTRP 084 C	Computer Aided Transcription: Eclipse	(1)
Total Units Required		21

SEMESTER 4		
CTRP 047 C	Machine Shorthand Speed Bldg 6	2
CTRP 053 C	Court/Conference Reporting: Congressional	3
CTRP 055 C, 056 C	Court/Conf. Reporting: Jury Charge 1 and 2	6
CTRP 072 C	Legal Procedures	4
CTRP 068 C	Advanced Vocabulary Development	1.5
MGT 143 C	Introduction to Legal Research	1
CTRP 058, 059 C	Machine Shorthand Challenge 180 and 200	4
CTRP 085 C	Computer Aided Trans: Dictionary Bldg.	1
Total Units Required		22.5

SUMMER SESSION		
CTRP 048 C	Machine Shorthand Speed Bldg 7	2
CTRP 060 C	Mach. Shorthand Challenge — 220	2
Total Units Required		4

SEMESTER 5		
*POSC 100 C	United States Government	3
CTRP 076 C	Court and Deposition Procedures	1.5
CTRP 081 C	Internship: Court Reporting	2
*BIOL 160 C	Integrated Medical Science	3
	or	
HI 102 C	Legal Aspects of Health Care	(2)
	or	
HS 147 C	Survey of Disease	(3)
CTRP 074 C	CSR/RPR/CBC/CCP Exam Prep.	1
CTRP 092 C	Realtime Writing Concepts	2
Total Units Required		11.5–12.5

PLUS 12–13 Units From the following graduation requirements:

Written Communication	3
Cultural Diversity	3
Mathematics	3–4
Art	3
Program Total Units	110.5–112.5

*Meets Partial Requirements for Associate Degree

**COURT REPORTING
CERTIFICATE Program Code: 1C21103**

Preparation for State Certificate Examination

The courses listed are required to meet the requirements of the Court Reporter’s Board. This program was accredited by the CR Board on March 7, 1978. Academic courses completed in Adult Education or a private Court Reporting School are not transferable.

To earn a certificate, students must complete the required courses as listed with a minimum grade of “C.” At least 50% of all course work must be completed at Cypress College.

STUDENTS MUST FURNISH THEIR OWN MACHINE AND PAPER

Required Courses are listed in suggested sequence:

Course #	Title	Units
SEMESTER 1		
CTRP 040 C	Beg. Machine Shorthand Theory	3
CTRP 041 C	Court Reporting Theory Review	3
CTRP 071 C	Legal Terminology and Rhetoric	3
MGT 055 C	Business English	3
CTRP 067 C	Basic Vocabulary Development	2
COUN 140 C	Educational Planning	.5
Total Units Required		14.5
SEMESTER 2		
CTRP 042 C, 043 C	Machine Shorthand Speed Bldg 1 and 2	4
CTRP 051 C	Court/Conference Reporting: Legal	3
HS 145 C	Survey of Medical Terminology	3
*ENGL 106 C	Critical Thinking	3
MGT 041 C	Survey of Business Law	3
	or	
MGT 240 C	Legal Environment of Business	(3)
	or	
MGT 241 C	Legal Aspects — Business Transactions	(3)
	or	
MGT 141 C	Personal Law	(3)
CTRP 073AC	Spelling for Modern Business	1
CTRP 073BC	Punctuation — Court Reporting	1
Total Units Required		18
SUMMER SESSION		
CTRP 044 C, 045 C	Machine Shorthand Speed Bldg 3 and 4	4
SEMESTER 3		
CTRP 057 C, 058 C	Mach. Shorthand Challenge — 160 and 180	4
CTRP 046 C	Machine Shorthand Speed Bldg 5	2
CTRP 052 C	Court/Conference Reporting: Medical	3
CTRP 072 C	Legal Procedures	4
CTRP 054 C	Two/Four Voice Testimony	3
CTRP 085 C	Computer Aided Trans: Dictionary Bldg.	1
Total Units Required		17
SEMESTER 4		
CTRP 059 C	Mach. Shorthand Challenge — 200	2
CTRP 047 C	Machine Shorthand Speed Bldg 6	2
CTRP 053 C	Court/Conference Reporting: Congressional	3
CTRP 055 C, 056 C	Court/Conf. Reporting: Jury Charge 1 and 2	6
CTRP 068 C	Adv. Vocabulary Development	1.5
CTRP 082 C	Computer Aided Transcription: ProCAT	1
	or	
CTRP 083 C	Computer Aided Transcription: Stenograph	(1)
	or	
CTRP 084 C	Computer Aided Transcription: Eclipse	(1)
	or	
CTRP 070 C	Computer Aided Trans: StenoCAT	(1)
MGT 143 C	Introduction to Legal Research	1
Total Units Required		16.5
SUMMER SESSION		
CTRP 048 C	Machine Shorthand Speed Bldg 7	2
CTRP 060 C	Mach. Shorthand Challenge — 220	2
Total Units Required		4

SEMESTER 5

CTRP 076 C	Court and Deposition Procedures	1.5
CTRP 081 C	Internship: Court Reporting	2
*BIOL 160 C	Integrated Medical Science	(3)
	or	
HS 147 C	Survey of Disease	3
CTRP 074 C	CSR/RPR/CBC/CCP Exam Preparation	1
CTRP 092 C	Realtime Writing Concepts	2
Total Units Required		8.5–9.5
Program Total Units		78.5–79.5

Note: Students are advised to contact a Business counselor for any questions regarding this program.

CALIFORNIA COURT REPORTERS BOARD ACCREDITATION

ACCREDITED COURT REPORTING PROGRAM

In order for the person to qualify from a school to take the state licensing examination, the person shall complete a program at a recognized school. For information concerning the minimum requirements that a court reporting program must meet in order to be recognized contact:

The Court Reporter's Board of California
2535 Capitol Oaks Drive, Suite 230
Sacramento, CA 95833

*CYPRESS COLLEGE BUSINESS/CIS DIVISION
COURT REPORTING PROGRAM*

This program was approved by the Court Reporter's Board on March 7, 1978. Academic courses completed in Adult Education are not transferable. Courses taken in Distance Education will be evaluated on an individual basis for transferability and hour requirements. Private school academics may be evaluated for certification to take the CSR examination. The California Court Reporter's Board sets the standards for hours of training under the following listed categories. The Cypress College program exceeds all state requirements. The student may go on to earn an Associate in Arts Degree or other specialized certificate. Students must furnish their own equipment, paper, and other supplies. Student must enter the program with a basic typing speed of 25 words per minute.

1. Machine Shorthand and Transcription — 2300 hours (Lab hours do not count for machine credit in this category, per the CR Board.)

CORE REQUIREMENTS:

CTRP 040 C	90
CTRP 041 C	90
CTRP 042 C–045 C	360
CTRP 046 C–048 C	270
CTRP 057 C–060 C	360
CTRP 050 C	90
CTRP 051 C	90
CTRP 052 C	90
CTRP 053 C	90
CTRP 054 C	90
CTRP 055 C	90
CTRP 056 C	90
CTRP 075 C	90
CTRP 089 C or 090 C or 096 C	90
Total Hours	1980

Core Requirements must be completed in order to qualify. Students must pass one ten (10) minute qualifier in CTRP 050 C to be eligible to take the state CSR licensing examination. Transfer students must demonstrate course comparability in speed building categories.

ELECTIVES — After completing the core requirements, students may gain additional machine hours by completing any of the following.

CTRP 049 C	90
CTRP 094 C	36
CTRP 095 C	36
CTRP 089 C or 090 C or 096 C	90

Total Hours 342

2. ENGLISH — 240 Hours required

MGT 055 C	Business English	54
ENGL 103 C	Reasoning and Writing	54
	or	
ENGL 106 C	Critical Thinking	(54)
CTRP 073AC	Spelling	18
CTRP 073BC	Punctuation	18
CTRP 067 C	Vocabulary	36
CTRP 068 C	Adv. Vocabulary Development	27
ENGL 135 C	Advanced Grammar	54

Total Hours 261

3. MEDICAL — 120 Hours required

HS 145 C	Survey of Medical Terminology	54
BIOL 160 C	Integrated Medical Science	54
	or	
HS 147 C	Survey of Disease	(54)
CTRP 052 C	Court/Conference Reporting: Medical	18

Total Hours 126

4. LEGAL — 150 Hours required

CTRP 071 C	Legal Term	54
MGT 041 C	Survey of Business Law	
	or	
MGT 141 C	Personal Law	
	or	
MGT 240 C	Legal Environment of Business	
	or	
MGT 241 C	Legal Aspects — Business Transactions	54
CTRP 076 C	Court and Depositions Procedures	54

Total Hours 162

5. KEYBOARDING: 45 words per minute net (Cypress requirement 50 net words per minute)

CTRP 072 C	Legal Procedures	90
------------	------------------	----

6. TRANSCRIPT PREPARATION — 25 Hours required

CTRP 073CC	Formatting, Style, and Usage	18
CTRP 073DC	Proofreading	18

Total Hours 36

7. RESOURCE MATERIALS — 5 Hours required

MGT 143 C	Legal Research	18
-----------	----------------	----

Total Hours 18

8. APPRENTICESHIP TRAINING/COURT OBSERVATION — 60 Hours required

CTRP 081 C	Internship: Court Reporting	36
	20 Hours — Court	
	20 Hours — Deposition	
	10 Hours — Observation — Off Campus (prior to 140 wpm)	

Observation Hours may be completed in various classes		
CTRP 074 C	CSR/RPR/CBC/CCP Exam Preparation	27

Total Hours 63

9. TECHNOLOGY — 60 Hours required

CTRP 092 C	Realtime Writing	36
CTRP 085 C	Dictionary Build (18,000 words)	18
CTRP 093 C	Information Technology	36

SELECT ONE OF THE FOLLOWING: 18 units

CTRP 082 C	ProCAT	
CTRP 083 C	Stenograph	
CTRP 084 C	Eclipse	
CTRP 070 C	StenoCAT	

Suggested Elective:

CTRP 065 C	Advanced CAT Systems	(36)
------------	----------------------	------

Total Hours 108

NOTE: An 18,000 word dictionary is required in order to take the CSR examination.

In order for a person to qualify from a school to take the state licensing examination, the person shall complete a program at a recognized school. For more information contact:

**Department of Consumer Affairs
Court Reporter's Board
2535 Capitol Oaks Drive, Suite 230
Sacramento, CA 92583
(916) 263-3660**

All candidates must have a high school diploma or equivalent to take the CSR examination.

*Section 2411(a)(7) of the CR Board regulations state that a student will be allowed a reduction in the required machine hours if a student is able to pass the qualifier examination before completing the hours described in Section 1 under Machine Shorthand and Transcription. This does not exempt a student from completing the core required classes in order to qualify.

(Revised April, 2008)

CAPTIONING CERTIFICATE Program Code: 1C31330

The Captioning Certificate is designed to prepare students who are interested in pursuing careers in broadcast captioning, both online and off-line, using the latest in realtime technology with specific application software. Students will be encouraged to explore all areas of the captioning arena for future possible employment opportunities. To earn a certificate, complete the required courses as listed with a minimum grade of "C." At least 50% of all course work must be completed at Cypress College.

Required courses are listed in suggested sequence:		Units
CTRP 085 C	Computer Aided Trans: Dict. Bldg.	1
CTRP 090 C	Court/Conf Reporting: Literary	3
CTRP 089 C	Court and Conf. Rptg.: Lit. II	3
CTRP 096 C	Court and Conf. Rptg: Lit. III	3
CTRP 092 C	Realtime Writing Concepts	2
CTRP 088 C	Internship: Captioning	2
CTRP 068 C	Adv. Vocabulary Development	1.5
CTRP 091 C	Advanced Dictionary Build	1
Total Units		16.5

CART* CERTIFICATE
***COMMUNICATION ACCESS**
REALTIME TRANSLATION **Program Code: 1C07821**
STUDENTS MUST FURNISH
THEIR OWN MACHINE AND PAPER

The CART (Communication Access Realtime Translation) Certificate will provide the student with an opportunity for future employment as a classroom captionist shadowing a hearing-impaired individual, providing a realtime translation of all proceedings. The training program provides for an internship experience, where students will learn first-hand the job duties of a CART reporter.

To earn a certificate, complete the required courses as listed with a minimum grade of "C." At least 50% of all course work must be completed at Cypress College.

Required courses are listed in suggested sequence:		Units
CIS 050 C	Intro — Comp and Software Concepts or	3
CIS 150 C	Microsoft Office Applications	(3)
CTRP 040 C	Beg. Machine Shorthand Theory	3
CTRP 041 C	Court Reporting Theory Review	3
CTRP 042 C	Machine Shorthand Speed Bldg 1	2
CTRP 043 C	Machine Shorthand Speed Bldg 2	2
CTRP 044 C	Machine Shorthand Speed Bldg 3	2
CTRP 045 C	Machine Shorthand Speed Bldg 4	2
CTRP 051 C	Court/Conference Reporting: Legal	3
CTRP 052 C	Court/Conference Rptg — Medical	3
CTRP 067 C	Basic Vocabulary Development	2
CTRP 068 C	Adv. Vocabulary Development	1.5
CIS 107 C	Introduction to Windows	1
CTRP 092 C	Realtime Writing Concepts	2
CTRP 079 C	Internship: CART	2
CTRP 090 C	Court/Conf Reporting: Literary	3
CTRP 089 C	Court and Conf. Rptg.: Lit. II	3
ENGL 180 C	Sign Language — SEE Level 1	3
CTRP 032 C	CTRP Career Exploration	1
Total Units		41.5

COMPUTER EDITOR (SCOPIST)
CERTIFICATE **Program Code: 1C07820**
STUDENTS MUST FURNISH
THEIR OWN MACHINE AND PAPER

The Computer Editor (Scopist) Certificate prepares the student for employment in the field of court reporting working one-on-one with a Certified Shorthand Reporter to prepare and edit official transcripts for court, depositions, hearings, and other venues.

To earn a certificate, the student must complete the required courses as listed with a minimum grade of "C." At least 50% of all course work must be completed at Cypress College.

Required courses are listed in suggested sequence:		Units
CIS 050 C	Intro — Comp and Software Concepts or	3
CIS 111 C	Computer Information Systems	(3)
CIS 107 C	Introduction to Windows	1
CTRP 040 C	Beg. Machine Shorthand Theory	3
CTRP 041 C	Court Reporting Theory Review	3
CTRP 071 C	Legal Terminology and Rhetoric	3
CTRP 073AC	Spelling for Modern Business	1
CTRP 073BC	Punctuation for Court Reporting	1
CTRP 073CC	Formatting, Style and Usage	1
CTRP 032 C	CTRP Career Exploration	1
CTRP 097 C	Internship: Scoping/Editing	1

Select a minimum of four units from the following courses:		4
Electives:		Units
CTRP 082 C	Computer Aided Transcription: ProCAT	1
CTRP 083 C	Computer Aided Transcription: Stenograph	1
CTRP 084 C	Computer Aided Transcription: Eclipse	1
CTRP 070 C	Computer Aided Transcription: StenoCAT	1
HS 145 C	Survey of Medical Terminology	3
MGT 055 C	Business English	3
MGT 143 C	Introduction to Legal Research	1
CTRP 067 C	Basic Vocabulary Development	2
CTRP 068 C	Adv. Vocabulary Development	1.5
Total Units		22

COURT AND AGENCY SERVICES
CERTIFICATE **Program Code: 1C30333**

The Court and Agency Services Certificate will provide the student with the necessary knowledge, skills, and training to be employed in the field of court and/or deposition agency administration and operations. The training provides for an internship experience of 40 hours.

To earn a certificate, the student must complete the required courses as listed with a minimum grade of "C." At least 50% of all course work must be completed at Cypress College.

Required courses are listed in the suggested sequence:		Units
CTRP 073AC	Spelling for Modern Business	1
CTRP 073BC	Punctuation for Court Reporting	1
CTRP 073CC	Formatting, Style and Usage	1
CTRP 073DC	Proofreading	1
CIS 102 C	Advanced MS Word Business Applications	4
CTRP 071 C	Legal Terminology and Rhetoric	3
CTRP 072 C	Legal Procedures	4
CTRP 076 C	Court and Deposition Procedures	3
CTRP 093 C	Information Technology — CTRP	2
MGT 143 C	Introduction to Legal Research	1
CTRP 033 C	Internship: Agency Services or	2
CTRP 034 C	Internship: Court Services	(2)
CTRP 062 C	Notary Public Exam Preparation	1
Total Units		24

LEGAL ADMINISTRATIVE ASSISTANT
CERTIFICATE **Program Code: 1C30459**

This certificate prepares the student to work in a variety of venues related to the legal profession including positions as a legal administrative assistant in a law office, or in the court system, and in a variety of other legal settings.

To earn a certificate, complete the required courses as listed with a minimum grade of "C." At least 50% of all course work must be completed at Cypress College.

Required courses are listed in suggested sequence:		Units
CTRP 073AC	Spelling for Modern Business	1
CTRP 073BC	Punctuation for Court Reporting	1
CTRP 071 C	Legal Terminology and Rhetoric	3
CIS 102 C	Advanced MS Word Business Applications	4
CTRP 072 C	Legal Procedures	4
CIS 150 C	Microsoft Office Applications	3
MGT 055 C	Business English	3
MGT 143 C	Introduction to Legal Research	1
CTRP 080 C	Internship: Law Office	2
Total Units		22

PROOFREADING CERTIFICATE

Program Code: 1C31331

This certificate provides the student with the necessary knowledge, skills, and background to work in the field of court reporting as a proofreader. To earn a certificate, a student must complete the required courses as listed with a minimum grade of “C.” At least 50% of all course work must be completed at Cypress College.

Required courses are listed in suggested sequence:		Units
CTRP 040 C	Beg. Machine Shorthand Theory	3
CTRP 041 C	Court Reporting Theory Review	1–3
CTRP 073AC	Spelling for Modern Business	1
CTRP 073BC	Punctuation for Court Reporting	1
CTRP 073CC	Formatting, Style and Usage	1
CTRP 073DC	Proofreading	1
CTRP 067 C	Basic Vocabulary Development	2
CTRP 068 C	Adv. Vocabulary Development	1.5
MGT 055 C	Business English	3
CTRP 086 C	Internship: Proofreading	1
Total Units		15.5–17.5

Court Reporting (CTRP)

CTRP 030 C CR Beginning Practice Lab 1 to 6 Units

Term hours: 54–324 laboratory depending on units attempted. This course is designed as an open entry lab to fulfill the Court Reporter’s Board lab requirements for court reporting students receiving instruction in theory to 100 words per minute. Fifty-four hours is required for one unit of credit. Variable Unit Class. May be taken for a cumulative total of 6 units. Open Entry/Open Exit. Pass/No Pass only. \$3.00 Material Fee — Payable at Registration.

CTRP 031 C CR Intermediate Practice Lab 1 to 6 Units

Term hours: 54–324 laboratory depending on units attempted. This course is designed as an open entry skill building lab to fulfill the Court Reporter’s Board lab requirements for students receiving instruction from 110 to 140 words per minute. Fifty-four hours is required for one unit of credit. (May be taken for a cumulative total of 6 units.) Pass/No Pass. \$3.00 Material Fee — Payable at Registration.

CTRP 032 C CTRP Career Exploration 1 Unit

Term hours: 16–18 lecture. This course is designed as a career exploration class for students interested in entering the legal field, court reporting, captioning, CART, text-entry, scoping, proofing, editing, and realtime writing. Pass/No Pass only.

CTRP 033 C Internship: Agency Services 2 Units

Term hours: 32–36 lecture and 40 hours of internship plus 10 hours of observation. This course provides practical work experience in an office setting in order to prepare the student to work in a court reporting agency. There will be 40 hours of internship required, plus 10 hours of observation.

CTRP 034 C Internship: Court Services 2 Units

Term hours: 32–36 lecture and 40 hours of internship plus 10 hours of observation. This course offers practical work experience in order to prepare the student to work in an administrative or clerical capacity in the California court system. There will be 40 hours of internship required, along with 10 hours of observation.

CTRP 035 C Advanced Practice Lab 1 to 6 Units

Term hours: 54–324 laboratory depending on units attempted. This course is designed as an open entry skill building lab to fulfill the California Court Reporter’s Board lab requirements for students receiving instruction from 140 to 180 words per minute. Fifty-four hours is required for one unit of credit. May be taken for a cumulative total of 6 units. Pass/No Pass. \$3.00 Material Fee — Payable at Registration.

CTRP 036 C CR High Speed Proficiency Lab 1 to 6 Units

Term hours: 54–324 laboratory depending on units attempted. This course is designed as an open entry skill building lab to fulfill the California Court Reporter’s Board lab requirements for students receiving instruction from 180 to 220 words per minute. May be taken for a cumulative total of 6 units. Open Entry/Open Exit. Pass/No Pass. \$3.00 Material Fee — Payable at Registration.

CTRP 037 C CR Qualifier Lab 1 to 6 Units

Term hours: 54–324 laboratory depending on units attempted. This course is designed as an open entry skill building lab to fulfill the California Court Reporter’s Board lab requirements for students in the qualifier program. Fifty-four hours is required for one unit of credit. May be taken for a cumulative total of 6 units. Open Entry/Open Exit. Pass/No Pass. \$3.00 Material Fee — Payable at Registration.

CTRP 040 C Beg. Machine Shorthand Theory 3 Units

Term hours: 48–54 lecture and 32–36 laboratory. This first semester course covers the basic theory of machine shorthand and mastery of the keyboard. This course meets partial requirements of the Court Reporter’s Board and the National Court Reporter’s Association. Recommend concurrent enrollment in CTRP 041 C. Three hours of court observation required. Pass/No Pass/Letter Grade Option.

CTRP 041 C Court Reporting Theory Review 1 to 3 Units

Prerequisite: Concurrent enrollment in or completion of CTRP 040 C.
Term hours: 32–36 lecture and 48–54 laboratory depending on units attempted. This course covers the basic theory of court reporting which emphasizes reporting theory, reading fluency, and transcribing skills. This course meets partial requirements of the Court Reporter’s Board and the National Court Reporter’s Association. May be taken for credit 3 times. Open Entry/Open Exit. Pass/No Pass/Letter Grade Option.

CTRP 042 C Machine Shorthand Speed Bldg 1 .5 to 2 Units

Prerequisite: Completion of CTRP 041 C.
Term hours: 16–18 lecture and 64–72 laboratory depending on units attempted. This course promotes further development of speed and accuracy in taking dictation on the machine. The student will review theory and develop sufficient skills to take new material dictation at 80 wpm for a minimum of three minutes with 95% accuracy. Units of credit will be granted when the speed and accuracy objective is attained. This course meets partial requirements of the Court Reporter’s Board and the National Court Reporter’s Association. May be taken for credit 4 times. Open Entry/Open Exit. Pass/No Pass/Letter Grade Option.

CTRP 043 C Machine Shorthand Speed Bldg 2 .5 to 2 Units

Prerequisite: Completion of CTRP 042 C.
Term hours: 16–18 lecture and 64–72 laboratory depending on units attempted. This course promotes further development of speed and accuracy in taking dictation on the machine. The student will review theory and develop sufficient skills to take new material dictation at 100 wpm for a minimum of five minutes with 95% accuracy. Units of credit will be granted when the speed and accuracy objective is attained. This course meets partial requirements of the Court Reporter’s Board and the National Court Reporter’s Association. May be taken for credit 4 times. Open Entry/Open Exit. Pass/No Pass/Letter Grade Option.

CTRP 044 C Machine Shorthand Speed Bldg 3 .5 to 2 Units*Prerequisite: Completion of CTRP 043 C.*

Term hours: 16–18 lecture and 64–72 laboratory depending on units attempted. This course promotes further development of speed and accuracy in taking dictation on the machine. The student will review techniques of writing and develop sufficient skills to take new material dictation at 120 wpm for five minutes with 95% accuracy. Units of credit will be granted when the speed and accuracy objective is attained. The course meets partial requirements of the Court Reporter's Board and the National Court Reporter's Association for speed level on jury charge material. May be taken for credit 4 times. Open Entry/Open Exit. Pass/No Pass/Letter Grade Option.

CTRP 045 C Machine Shorthand Speed Bldg 4 .5 to 2 Units*Prerequisite: Completion of CTRP 044 C.*

Term hours: 16–18 lecture and 64–72 laboratory depending on units attempted. This course promotes further development of speed and accuracy in taking dictation on the machine. The student will review techniques of writing and develop sufficient skills to take new material dictation at 140 wpm for five minutes with 95% accuracy. Units of credit will be granted when the speed and accuracy objective is attained. This course meets partial requirements of the Court Reporter's Board and the National Court Reporter's Association for speed level on jury charge material. May be taken for credit 4 times. Open Entry/Open Exit. Pass/No Pass/Letter Grade Option.

CTRP 046 C Machine Shorthand Speed Bldg 5 .5 to 2 Units*Prerequisite: Completion of CTRP 045 C.*

Term hours: 16–18 lecture and 64–72 laboratory depending on units attempted. This course promotes further development of speed and accuracy in taking dictation on the machine. The student will develop sufficient skills to take new material dictation at 160 wpm for five minutes with 98% accuracy. Units of credit will be granted when the speed and accuracy objective is attained. This course meets the requirements of the Court Reporter's Board and the National Court Reporter's Association for speed level on question and answer and trial testimony. May be taken for credit 4 times. Open Entry/Open Exit. Pass/No Pass/Letter Grade Option.

CTRP 047 C Machine Shorthand Speed Bldg 6 .5 to 2 Units*Prerequisite: Completion of CTRP 046 C.*

Term hours: 16–18 lecture and 64–72 laboratory depending on units attempted. This course promotes further development of speed and accuracy in taking dictation on the machine. The student will develop sufficient skills to take new material dictation at 180 wpm for ten minutes with 98% accuracy. Units of credit will be granted when the speed and accuracy objective is attained. This course meets the requirements of the Court Reporter's Board and the National Court Reporter's Association for speed level on question and answer and trial testimony. May be taken for credit 4 times. Open Entry/Open Exit. Pass/No Pass/Letter Grade Option.

CTRP 048 C Machine Shorthand Speed Bldg 7 .5 to 2 Units*Prerequisite: Completion of CTRP 047 C.*

Term hours: 16–18 lecture and 64–72 laboratory depending on units attempted. This course promotes further development of speed and accuracy in taking dictation on the machine. The student will develop sufficient skills to take new material dictation at 200 wpm for 10 minutes with 98% accuracy. Units of credit will be granted when the speed and accuracy objective is attained. This course meets the requirements of the Court Reporter's Board and the National Court Reporter's Association for speed level on question and answer and trial testimony. May be taken for credit 4 times. Open Entry/Open Exit. Pass/No Pass/Letter Grade Option.

CTRP 049 C Machine Shorthand Speed Bldg 8 .5 to 2 Units*Prerequisite: Completion of CTRP 048 C.*

Term hours: 16–18 lecture and 64–72 laboratory depending on units attempted. This course promotes further development of speed and accuracy in taking dictation on the machine. The student will develop sufficient skills to take new material at 200 and 220 wpm sustained dictation with 98% accuracy. Units of credit will be granted when the speed and accuracy objective is attained. This course meets the requirements of the Court Reporter's Board and the National Court Reporter's Association for speed level on question and answer and trial testimony. May be taken for credit 4 times. Open Entry/Open Exit. Pass/No Pass/Letter Grade Option.

CTRP 050 C CSR/RPR Directed Practice .5 to 2 Units

Term hours: 16–18 lecture and 64–72 laboratory depending on units attempted. This course promotes a further development of speed and accuracy in taking dictation on the machine. The student will develop sufficient skills to take new material dictation at speeds up to 240/260 wpm. Units of credit will be granted when the speed and accuracy objective is attained. This course meets the requirements of the Court Reporter's Board and the National Court Reporter's Association for speed level on question and answer and trial testimony. May be taken for credit 4 times. Open Entry/Open Exit. Pass/No Pass/Letter Grade Option.

CTRP 051 C Court/Conference Reporting: Legal 1 to 3 Units*Prerequisite: CTRP 042 C and CTRP 071 C.*

Term hours: 32–36 lecture and 48–54 laboratory depending on units attempted. This course consists of an application of court reporting theory to the keyboard to develop dictation rates of 60–100 wpm for a minimum of three minutes with 95% accuracy. Emphasis is on jury charge, literary, and question and answer material. Legal vocabulary, acceptable California formats, and court reporting punctuation rules are introduced. Three hours of court observation required. May be taken for credit 4 times. Open Entry/Open Exit. Pass/No Pass/Letter Grade Option.

CTRP 052 C Court/Conference Reporting: Medical 1 to 3 Units*Prerequisite: CTRP 044 C and HS 145 C.*

Term hours: 32–36 lecture and 48–54 laboratory depending on units attempted. This course applies court reporting theory to the keyboard to develop dictation rates of 120–140 words per minute for a minimum of three minutes with 95% accuracy with emphasis on medical terminology. Three hours of court observation required. May be taken for credit 4 times. Open Entry/Open Exit. Pass/No Pass/Letter Grade Option.

CTRP 053 C Court/Conference Reporting: Congressional 1 to 3 Units*Prerequisite: CTRP 045 C.*

Term hours: 32–36 lecture and 48–54 laboratory depending on units attempted. This course offers further development of speed and accuracy in taking dictation to increase machine shorthand speed and strengthen transcription skills with emphasis on congressional record material, at speeds ranging from 160–180 wpm for a minimum of three minutes with 95% accuracy. May be taken for credit 4 times. Open Entry/Open Exit.

CTRP 054 C Two/Four Voice Testimony .5 to 3 Units*Prerequisite: CTRP 044 C and CTRP 073CC.*

Term hours: 32–36 lecture and 48–54 laboratory depending on units attempted. This course develops familiarity with a simulated courtroom scene consisting of the judge, the clerk, attorneys for the plaintiff and the defendant, and a witness participating in two/four-voice dictation. Students will identify each speaker with appropriate machine designations in multi-voice testimony at 120–140 wpm for a minimum of three minutes, transcribed in proper format with 98% accuracy. May be taken for credit 4 times. Open Entry/Open Exit. Pass/No Pass/Letter Grade Option.

CTRP 055 C Court/Conf. Rptg: Jury Charge 1 .5 to 3 Units*Prerequisite: CTRP 045 C.*

Term hours: 32–36 lecture and 48–54 laboratory depending on units attempted. This course presents an intensive application of court reporting theory to develop further reading and transcribing skills in jury charge, opening and closing arguments, legal opinion and other courtroom material at speeds ranging from 160 to 180 wpm. This course prepares the student for the machine portion of the RPR examination. May be taken for credit 4 times. Open Entry/Open Exit. Pass/No Pass/Letter Grade Option.

CTRP 056 C Court/Conf. Rptg: Jury Charge 2 .5 to 3 Units*Prerequisite: CTRP 055 C.*

Term hours: 32–36 lecture and 48–54 laboratory depending on units attempted. This course presents an intensive application of court reporting theory to develop further reading and transcribing skills in jury charge, opening and closing arguments, legal opinion and other courtroom material at speeds ranging from 180 to 200 wpm. This course prepares the student for the machine portion of the RPR examination. May be taken for credit 4 times. Open Entry/Open Exit. Pass/No Pass/Letter Grade Option.

CTRP 057 C Mach. Shorthand Challenge — 160 .5 to 2 Units*Prerequisite: CTRP 045 C and CTRP 054 C.*

Term hours: 16–18 lecture and 64–72 laboratory depending on units attempted. This course is designed for the advanced court reporting student and the transfer student to gain additional proficiency in taking multiple-voice testimony in a simulated environment at 160 wpm. Live reading will be introduced. May be taken for credit 4 times. Open Entry/Open Exit. Pass/No Pass/Letter Grade Option.

CTRP 058 C Mach. Shorthand Challenge — 180 .5 to 2 Units*Prerequisite: CTRP 057 C.*

Term hours: 16–18 lecture and 64–72 laboratory depending on units attempted. This course is designed for the advanced court reporting student and the transfer student to gain additional proficiency in taking multiple-voice testimony in a simulated environment at 180 wpm. Live reading will be introduced. May be taken for credit 4 times. Open Entry/Open Exit. Pass/No Pass/Letter Grade Option.

CTRP 059 C Mach. Shorthand Challenge — 200 .5 to 2 Units*Prerequisite: CTRP 058 C.*

Term hours: 16–18 lecture and 64–72 laboratory depending on units attempted. This course is designed for the advanced court reporting student and the transfer student to gain additional proficiency in taking multiple-voice testimony in a simulated environment at 200 wpm. Videotaped testimony and live reading will be introduced. May be taken for credit 4 times. Open Entry/Open Exit. Pass/No Pass/Letter Grade Option.

CTRP 060 C Mach. Shorthand Challenge — 220 .5 to 2 Units*Prerequisite: CTRP 059 C.*

Term hours: 16–18 lecture and 64–72 laboratory depending on units attempted. This course is designed for the advanced court reporting student to gain additional proficiency in taking multiple-voice testimony in a simulated environment at 220 wpm. Videotaped testimony and live reading will be introduced. May be taken for credit 4 times. Open Entry/Open Exit. Pass/No Pass/Letter Grade Option.

CTRP 062 C Notary Public Exam Preparation .5 to 1 Units

Term hours: 8–18 lecture depending on units attempted. This course is designed to prepare students to take and pass the California State Notary Public examination. May be taken for credit 2 times. Open Entry/Open Exit. Pass/No Pass/Letter Grade Option.

CTRP 065 C Advanced CAT Systems .5 to 2 Units*Advisory: The student must have completed a CAT (Computer-Aided Transcription) dictionary.*

Term hours: 8–36 lecture and 8–36 laboratory TBA depending on units attempted. This course is designed as an advanced CAT (Computer Aided Transcription) class to provide further instruction in CAT based court reporting software programs. A heavy emphasis will be placed on document production. May be taken for credit 4 times.

CTRP 066 C Machine Transcription — Medical 2 Units*Prerequisite: CIS 101 C, or CIS 125 C, or a minimum of 20 wpm.**Advisory: HS 145 C or a knowledge of medical terminology is recommended.*

Term hours: 16–18 lecture and 48–54 laboratory. This course is designed to teach medical transcription skills. Physician's correspondence, case histories, and reports will be transcribed using transcribing machines and a personal computer. \$3.00 Material Fee — Payable at Registration. Pass/No Pass/Letter Grade Option.

CTRP 067 C Basic Vocabulary Development 2 Units

Term hours: 32–36 lecture. This course is a basic course designed to enrich vocabulary and improve spelling. The emphasis is on increasing general business and professional terminology.

CTRP 068 C Adv. Vocabulary Development 1.5 Units*Prerequisite: CTRP 067 C.*

Term hours: 24–27 lecture. This course is an advanced course designed to enrich vocabulary and improve spelling. The emphasis is on increasing general business and professional terminology.

CTRP 070 C Comp. Aided Trans: StenoCAT 1 Unit

Term hours: 16–18 lecture and 48–54 laboratory TBA. This course uses computer-based instruction as well as hands-on applications to introduce the court reporting student to StenoCAT Computer Aided Transcription software using personal computers.

CTRP 071 C Legal Terminology and Rhetoric 3 Units

Term hours: 48–54 lecture. The course includes instruction in the terminology used in legal proceedings and legal documents. The topics covered include terminology in civil and criminal litigation and cases in equity.

CTRP 072 C Legal Procedures 4 Units*Prerequisite: Typing speed of 40 wpm, and CTRP 071 C.*

Term hours: 64–72 lecture and 16–18 laboratory. This course is designed to train the legal secretarial, paralegal, or court reporting student in legal procedures and practical law office skills and knowledge in the areas of general office duties, non-court documents, the courts, court documents, litigation, appeals, and other court actions. This course may be taught using a computer. Three hours of court observation required.

CTRP 073AC Spelling for Modern Business 1 Unit

Term hours: 16–18 lecture. This course is designed as an 18-hour intensive review of frequently misspelled words, homonyms, synonyms, and antonyms. The emphasis will be on business, legal, medical, and technical terminology. This course meets partial requirements of the Court Reporter's Board for Section II and the Certification Program.

CTRP 073BC Punctuation — Court Reporting 1 Unit

Term hours: 16–18 lecture. This course is designed as an 18-hour intensive review of punctuation styles and rules used in court documents, letters, legal office documents, contracts, memorandums, and reports. The emphasis will be on basic punctuation rules as they apply to written business, legal, medical, and technical documents. This course meets partial requirements of the Court Reporter's Board for Section II and the Certification Program.

CTRP 073CC Formatting, Style and Usage 1 Unit

Term hours: 16–18 lecture. This course is designed to provide the court reporting student and the computer editor major with instruction in preparing and formatting California court transcripts and depositions. Instruction will include format styles, usage, and fundamentals of document production using the computer.

CTRP 073DC Proofreading 1 Unit

Term hours: 16–18 lecture. This course is designed to provide the court reporting student with instruction in editing and proofreading in order to prepare a final California court transcript, deposition, hearing transcript or other related legal document. May be taken for credit 3 times.

CTRP 074 C CSR/RPR/CBC/CCP Exam Preparation .5 to 3 Units

Term hours: 8–54 lecture depending on units attempted. This course is designed to prepare the student to successfully pass the written portion of any or all of the following examinations: CSR, RPR, CBC or CCP. May be taken for a cumulative total of 3 units. Pass/No Pass only.

CTRP 075 C Simulated Courtroom .5 to 6 Units

Prerequisite: CTRP 046 C.

Term hours: 16–18 lecture and 64–72 laboratory depending on units attempted. This course is designed to offer a simulated courtroom and deposition environment with special emphasis on live reading with 2, 3, 4, and 5-voice dictation practice at speeds ranging from 180 to 200 wpm. May be taken for a cumulative total of 6 units. Open Entry/Open Exit.

CTRP 076 C Court and Deposition Procedures .5 to 3 Units

Prerequisite: CTRP 072 C.

Term hours: 8–54 lecture depending on units attempted. This course provides extensive training in court and deposition procedures with heavy emphasis on court structure, pre-trial and trial procedures, law office procedures, ethics, and document production. May be taken for a cumulative total of 3 units. Open Entry/Open Exit.

CTRP 077 C Dictation/Transcription .5 to 6 Units

Term hours: 8–108 lecture and 32–324 laboratory depending on units attempted. This course provides further development of speed and accuracy in taking dictation on the machine at a variety of speeds. Emphasis is on reinforcement and improvement. May be taken for a cumulative total of 6 units. Open Entry/Open Exit. Pass/No Pass only.

CTRP 078 C Internship: Medical Reporting 2 Units

Prerequisite: CTRP 052 C and HS 145 C.

Term hours: 32–36 lecture and 40 hours of internship plus 10 hours of observation. This course is designed to provide the court reporting medical transcriptionist student with practical work experience recording and reporting medical lectures, seminars, and hearings. There will be 40 hours of internship plus 10 hours of observation.

CTRP 079 C Internship: CART 2 Units

Prerequisite: CTRP 045 C.

Term hours: 32–36 lecture and 40 hours of internship plus 10 hours of observation. This course is designed to provide the CART (Communication Access Realtime Translation) student with practical work experience recording and reporting seminars, hearings, and lectures. There will be 40 hours of internship plus 10 hours of observation.

CTRP 080 C Internship: Law Office 2 Units

Prerequisite: CTRP 072 C.

Term hours: 32–36 lecture and 40 hours in a law office or legal environment plus 10 hours of observation. This course offers practical work experience in an approved law office in the County of Orange or Los Angeles. Internship will be scheduled during the semester, depending on available law office openings. This course fulfills partial requirements of the Legal Secretary Certificate and Degree Programs.

CTRP 081 C Internship: Court Reporting 1 to 2 Units

Prerequisite: CTRP 047 C.

Term hours: 16–36 lecture depending on units attempted and 40 hours in the courtroom or in deposition proceedings plus 10 hours of observation. This course offers practical work experience in approved court and deposition proceedings. Internship will be scheduled during the semester, depending on available court and deposition openings. This course fulfills partial requirements of the Court Reporter's Board.

CTRP 082 C Computer Aided Trans: ProCAT 1 Unit

Prerequisite: Students must have completed a CAT (Computer-Aided Transcription) dictionary.

Term hours: 16–18 lecture and 48–54 laboratory TBA. This course uses computer-based instructions as well as hands-on applications to introduce the court reporting student to ProCAT Computer Aided Transcription software.

CTRP 083 C Computer Aided Trans: Stenograph 1 Unit

Prerequisite: Students must have completed a CAT (Computer-Aided Transcription) dictionary.

Term hours: 16–18 lecture and 48–54 laboratory TBA. This course uses computer based instruction as well as hands-on applications to introduce the court reporting student to Stenograph Computer-Aided Transcription software.

CTRP 084 C Computer Aided Trans: ECLIPSE 1 Unit

Prerequisite: Students must have completed a CAT (Computer-Aided Transcription) dictionary.

Term hours: 16–18 lecture and 48–54 laboratory TBA. This course uses computer-based instruction as well as hands-on applications to introduce the court reporting student to ECLIPSE Computer-Aided Transcription software.

CTRP 085 C Computer Aided Trans: Dict. Bldg. 1 Unit

Prerequisite: Completion of CTRP 043 C.

Term hours: 16–18 lecture and 48–54 laboratory TBA. This course will enable court reporting students to start building their personal dictionary using one of several CAT (Computer Aided Transcription) software systems.

CTRP 086 C Internship: Proofreading 1 Unit

Term hours: 16–18 lecture. This course offers practical work experience in proofreading in order to prepare court, deposition, and other legal documents. Internship will be scheduled within the court reporting community. There will be 20 hours of internship required. May be taken for credit 2 times.

CTRP 087 C Internship: Hearing Reporter .5 to 2 Units

Prerequisite: Completion of 160 wpm speed building.

Term hours: 8–36 lecture depending on units attempted and 40 hours of internship plus 10 hours of observation. This course offers practical work experience in the field of hearing reporting. Students will work in the field taking hearings, meetings, conferences, seminars, and workman's compensation proceedings. There will be 40 hours internship, plus 10 hours of observation. May be taken for credit 4 times.

CTRP 088 C Internship: Captioning 2 Units

Term hours: 32–36 lecture and 40 hours of internship plus 10 hours of observation. This course offers practical work experience in the field of captioning, both on-line and off-line. Internship will be scheduled during the semester at various sites, including on-campus opportunities for development and perfection of captioning skills. A 15,000 word CAT dictionary is necessary to complete captioning projects. There will be 40 hours of internship, plus 10 hours of observation. May be taken for credit 4 times.

CTRP 089 C Court and Conf. Rptg.: Lit. II .5 to 3 Units

Term hours: 8–36 lecture and 24–54 laboratory. This course is designed to prepare the student to record a variety of literary dictation material at speeds ranging from 140 to 180 wpm. Students will be introduced to a broad spectrum of vocabulary with special emphasis on topics that will lead to a career in Communication Access Realtime Translation (CART) reporting. May be taken for credit 4 times. Open Entry/Open Exit. Pass/No Pass/Letter Grade Option.

CTRP 090 C Court/Conf. Rptg: Literary 1 to 3 Units

Prerequisite: CTRP 043 C or 100 words per minute.

Term hours: 32–36 lecture and 48–54 laboratory depending on units attempted. This course is designed to prepare the student to record a variety of literary dictation material at speeds ranging from 110 to 150 wpm. Students will be introduced to a broad spectrum of vocabulary designed to prepare them for convention reporting, hearing reporting, stenointerpreting, and other alternative careers. May be taken for credit 4 times. Open Entry/Open Exit.

CTRP 091 C Advanced Dictionary Build 1 Unit

Term hours: 16–18 lecture and 48–54 laboratory. This course is designed for court reporting students and captionists in order to further develop, modify, and refine their personal dictionary using one of several Computer Aided Transcription software systems.

CTRP 092 C Realtime Writing Concepts 2 Units

Prerequisite: CTRP 085 C and CTRP 046 C.

Term hours: 16–18 lecture and 48–54 laboratory. A programmed approach is used with guided instructions to introduce court reporting students to realtime writing. Students will use their completed electronic dictionary and the appropriate software with which their electronic dictionary is compatible. Students will use hands-on application to write various exercises covering a variety of concepts in realtime.

CTRP 093 C Information Technology — CTRP 2 Units

Term hours: 32–36 lecture. This course is designed to introduce students to court reporting information technology, hardware technology, software applications, research links, auxiliary equipment, and CAT industry requirements. Pass/No Pass/Letter Grade Option.

CTRP 094 C Expert Testimony — Prof Reporter 2 Units

Term hours: 32–36 lecture. This class is designed for students and reporters to further develop dictionary refinement and writing skills in realtime. Students must furnish a steno machine, a laptop computer, and other related court reporting supplies. May be taken for credit 4 times.

CTRP 095 C Realtime Writing — Prof Reporter 2 Units

Term hours: 32–36 lecture. This class is an advanced realtime writing class designed for students and reporters who studied a non-compatible computer theory. The class focuses on realtime writing concepts and their application to dictionary development, conflict resolution, and non-translates. Students are required to furnish their own steno machine, laptop computer, and other related court reporting supplies. May be taken for credit 4 times.

CTRP 096 C Court and Conf. Rptg: Lit. III 1 to 3 Units

Prerequisite: CTRP 046 C or 160 wpm.

Term hours: 32–36 lecture and 48–54 laboratory depending on units attempted. This course is designed to prepare the student to record a variety of literary dictation material at speeds ranging from 180 to 220 wpm. Students will be introduced to a broad spectrum of vocabulary designed to prepare them for convention reporting, hearing reporting, steno interpreting, and closed captioning. May be taken for credit 4 times. Open Entry/Open Exit. Pass/No Pass/Letter Grade Option.

CTRP 097 C Internship: Scoping/Editing 1 Unit

Term hours: 16–18 lecture. This course offers practical work experience in scoping/editing in order to prepare court, deposition, and other legal documents. Internship will be scheduled with members of the court reporting community. There will be 20 hours of internship required.

CTRP 098 C Court Reporting Seminar .5 to 12 Units

Prerequisite: May be required.

Corequisite: May be required.

Advisory: May be required.

Term hours: 0–216 lecture and 0–1296 laboratory depending on units attempted. This course will utilize a lecture and/or laboratory approach for students enrolled in the Court Reporting Program to increase their knowledge in applied areas. A variety of classes will be offered to increase the student's knowledge of the court reporting profession by updating content on recent changes and requirements and by preparing for new trends in court reporting. May be taken for credit 1–4 times. Pass/No Pass or Pass/No Pass/Letter Grade Option or Standard Letter Grade. Fees may be required — Payable at Registration.

CTRP 099 C Court Reporting: Independent Study .5 to 2 Units

Term hours: The number of class hours or activities per week will be determined by the scope of the topic. The instructor will devise learning strategies to be followed by the student. This course is designed for students who wish to gain further experience, knowledge, or expertise in applied areas of court reporting. Students must obtain permission from the program coordinator to be enrolled in this class. This course does not meet the requirements of the Court Reporting Certificate. This course may be used to fulfill hour requirements as mandated by the Court Reporter's Board. Prerequisite: Approved Independent Study Learning Contract. May be taken for credit 4 times. Pass/No Pass only.

Culinary Arts — See Hospitality, Restaurant, Culinary Arts (HRC)

Dance

Division of Fine Arts

Division Dean — Ting-Pi (Joyce) Carrigan

Faculty

Maha Haddad

Erin Landry

Counselors

Renay Laguana-Ferinac

Renee Ssensalo

PROGRAM LEARNING OUTCOMES (PLOs)

Dance Department

- Given a dance performance or teaching setting, students will be able to demonstrate knowledge of various dance techniques, choreography, performance and history of dance forms.
- Given a dance performance setting, students will be able to communicate dramatic and emotional content through choreography and dance.
- Given a dance performance students will be able to analyze dance works for their historical origins and choreographic technique.

ASSOCIATE IN ARTS DEGREE

DANCE

Program Code: 1A03781

Students will receive a well rounded dance education that will prepare them to transfer as dance majors or to teach, choreograph, and perform at various community and private venues.

To earn an Associate Degree students must complete: (1) all major course requirements with a minimum grade of "C"; (2) 25 units of General Education Graduation Requirements; (3) the cultural diversity and reading requirements; (4) any elective courses to complete a minimum of 60 units; and, (5) have a minimum GPA of 2.0. At least 50% of all major course work must be completed at Cypress College. Courses that fulfill major requirements for an Associate Degree at Cypress College might not be the same as those required for completing the major at a transfer institution offering a Baccalaureate Degree. For information on specific university requirements, please consult with your counselor, or visit the Transfer Center.

Required Courses		Units
DANC 101 C	Multicultural Dance in the U.S.	3
DANC 105 C	Ballet I	1.5
DANC 106 C	Classical Dance	2
DANC 107 C	Modern Dance	1.5
DANC 108 C	Free Form Dance	1.5
DANC 111 C	Beginning Jazz Dance	1.5
DANC 113 C	Tap Dance	1
DANC 112 C	Intermediate Jazz Dance	2
	or	
DANC 215 C	Commercial Dance	(2)
DANC 202 C	Elements of Choreography	2
DANC 204 C	Dance Rehearsal and Performance	3
DANC 214 C	Dance Repertory	3

Select 2 courses from the following:	Units	
DANC 100 C	Intro to Dance Appreciation	3
DANC 109 C	Dance Improvisation	1
DANC 114 C	Rhythm Dance	2
DANC 124 C	Partnering	1
DANC 208 C	Pointe Class	1

Select 3 courses from the following:	Units	
DANC 115 C	Hip-Hop Dance	1
DANC 130 C	Afro-Caribbean Dance	1
DANC 131 C	Ballet Folklorico	1–2
DANC 132 C	Flamenco Dance	1
DANC 133 C	Dance of Andalusia	1.5
DANC 136 C	Middle Eastern Dance	1
DANC 137 C	Latin and Swing Dance	1
DANC 139 C	Ballroom I	1

Select 2–3 units from the following:	Units	
THEA 140 C	Introduction to Theater Design	3
	or	
THEA 145 C	Fundamentals of Costume Design	(3)
THEA 142 C	Theater Sound and Recording	2
	or	
MUS 124 C	Recording Studio I	(3)
THEA 144 C	Lighting Design Fundamentals	3
	Total Units	29–34.5

DANCE TEACHING CERTIFICATE

Program Code: 1K12959

This program is designed to prepare the student to teach dance at private dance studios and community centers.

To earn a certificate, students must complete the required courses as listed with a minimum grade of "C." At least 50% of all course work must be completed at Cypress College.

Required courses are listed in numeric sequence:

Course #	Title	Units
DANC 102 C	Pilates Mat Work	1
DANC 106 C	Classical Dance	1.5
DANC 108 C	Free Form Dance	1.5
DANC 109 C	Dance Improvisation	1
DANC 112 C	Intermediate Jazz Dance	1.5
DANC 114 C	Rhythm Dance	1
DANC 130 C	Afro-Caribbean Dance	1
DANC 132 C	Flamenco Dance	1
DANC 202 C	Elements of Choreography	2
DANC 230 C	Dance Teaching Methodologies	3
PE 236 C	Prev and Care/Athletic Injuries	3
	Total Units Required	17.5

Electives

THEA 120 C	Acting I	3
THEA 126 C	Musical Theater Techniques	3

DANCE TRANSFER PROGRAM

Students should consult a counselor or www.assist.org for lower division major requirements for most California public universities. (See the Standard Definitions section of the catalog for a description of ASSIST.) Students transferring to an independent college/university should consult the catalog of the individual school and a counselor for lower division major requirements.

Dance (DANC)

DANC 100 C Introduction to Dance Appreciation 3 Units

Term hours: 32–36 lecture and 48–54 laboratory. Students will learn the basic dance technique of ballet, modern and jazz and a world dance form. Historical background will be provided. Dance concert admission may not exceed \$30.00 (UC/CSU, AA GE, CSU GE)

DANC 101 C Multicultural Dance in the U.S. 3 Units

Advisory: Eligibility for ENGL 100 C.

Term hours: 48–54 lecture. Social and theatrical dances of the U.S. today will be viewed and examined in terms of cultural influences, historical and social origins, and the functions they fulfill for individual artists, their cultures, and society in general. African American, Asian, Hispanic, European and Native American dances, choreographers and dancers will be studied. The class work will include readings, discussions, group projects, and analysis of dance performances on video and live theater. Attendance at a selected group of performances is required. Cost of dance concert admission will not exceed \$40.00. (UC/CSU, AA GE, CSU GE, IGETC, CUL DIV)

DANC 102 C Pilates Mat Work 1 to 2 Units

Term hours: 32–72 laboratory depending on units attempted. This class is designed to prepare a student mentally and physically for dance. Students will learn Pilates floor mat exercises and a floor barre to increase flexibility, strength, body alignment with emphasis on strengthening the core muscle groups. May be taken for credit 4 times. Pass/No Pass/Letter Grade Option.

DANC 105 C Ballet 1 to 2 Units

Term hours: 32–72 laboratory depending on units attempted. This course introduces the rudiments of classical ballet to the beginning dance student. The students will develop the strength and coordination to perform the technical skills of basic ballet through barre and center work and by learning simple movement combinations. Ballet terminology will be covered. May be taken for credit 4 times. Pass/No Pass/Letter Grade Option. Dance concert admission will not exceed \$12.00. (UC/CSU, AA GE, CSU GE)

DANC 106 C Classical Dance 1 to 2 Units

Prerequisite: Demonstrated mastery of beginning level dance technique.

Term hours: 32–72 laboratory depending on units attempted. This class covers the rudiments of classical dance for the intermediate ballet student. The student will develop technical skills to perform intermediate level steps and combinations of movement. Classical dance terminology will be covered. May be taken for credit 4 times. Dance concert admission will not exceed \$12. (UC/CSU, AA GE, CSU GE)

DANC 107 C Modern Dance 1 to 2 Units

Term hours: 32–72 laboratory depending on units attempted. Using a variety of music styles students will learn and create dances that dynamically convey thoughts, feelings and ideas. Participation develops an expressive movement vocabulary while building strength and coordination. May be taken for credit 4 times. Variable unit class. May be taken for credit 4 times. Pass/No Pass/Letter Grade Option. Dance concert admission will not exceed \$30.00. (UC/CSU, AA GE, CSU GE)

DANC 108 C Free Form Dance 1.5 Units

Prerequisite: Demonstrated mastery of beginning level dance technique.

Term hours: 48–54 laboratory. Using a variety of music styles, students will learn and create intermediate level dances that convey thoughts, feelings and ideas. Students will broaden their movement range and become more coordinated and dynamic as movers. May be taken for credit 4 times. Dance concert admission will not exceed \$30.00. (UC/CSU, AA GE, CSU GE)

DANC 109 C Dance Improvisation 1 Unit

Term hours: 32–36 laboratory. This course is designed to train the mind and body to respond and explore creative movement problems through improvisation. Choreographic concepts will be studied through improvisation. May be taken for credit 4 times. (UC/CSU, CSU GE)

DANC 111 C Beginning Jazz Dance 1 to 2 Units

Term hours: 32–72 laboratory depending on units attempted. Students will learn basic skills of jazz dance with emphasis on body alignment, strength and coordination. May be taken for credit 2 times. Pass/No Pass/Letter Grade Option. Dance concert admission not to exceed \$30. (UC/CSU, AA GE, CSU GE)

DANC 112 C Intermediate Jazz Dance 1 to 2 Units

Prerequisite: Demonstrated mastery of beginning level dance techniques.

Term hours: 32–72 laboratory depending on units attempted. Students will further develop their technical skills for jazz dance and learn faster, more complicated movement combinations appropriate for the intermediate dancer. May be taken for credit 2 times. Pass/No Pass/Letter Grade Option. Dance concert admission will not exceed \$12.00. (UC/CSU, AA GE, CSU GE)

DANC 113 C Tap Dance 1 Unit

Term hours: 32–36 laboratory. Students will study basic tap dance technique and elementary tap dances. The class provides students with the opportunity to develop coordination, rhythm and performance skills for tap dance. Some history of tap will be included. May be taken for credit 4 times. Pass/No Pass/Letter Grade Option. Cost of dance concert admission will not exceed \$30.00. (UC/CSU)

DANC 114 C Rhythm Dance 2 Units

Prerequisite: Demonstrated mastery of beginning level dance technique.

Term hours: 64–72 laboratory. Students will develop skills in rhythm dancing by studying intermediate level movements and combinations with some provision for student composition of dance. Performance skills will be included. May be taken for credit 4 times. Pass/No Pass/Letter Grade Option. Cost of dance concert admission will not exceed \$30.00. (UC/CSU)

DANC 115 C Hip-Hop Dance 1 Unit

Term hours: 32–36 laboratory. Students will learn various forms of beginning hip-hop dance, including pop and lock, hip-hop funk, syncopations and rhythms. A basic history of hip-hop culture will be discussed. May be taken for credit 4 times. Pass/No Pass/Letter Grade Option. Dance concert admission will not exceed \$30.00. (CSU)

DANC 120 C Dance History 3 Units

Term hours: 48–54 lecture. History of Dances uses readings, audiovisual media, lectures and in-class discussion to enable students to study the history of dance from its origins to present day. Students will also compare various dance techniques, theories and choreographers. Pass/No Pass/Letter Grade Option. Cost of dance concert not to exceed \$12.00. (UC/CSU, AA GE, CSU GE, IGETC)

DANC 121 C Turns 1 Unit

Prerequisite: Demonstrated mastery of beginning level dance technique.

Term hours: 32–36 laboratory. This course will cover beginning to advanced turns for modern, ballet and jazz dance. May be taken for credit 4 times. (UC/CSU)

DANC 122 C Stretch and Relaxation .5 to 1.5 Units

Term hours: 16–54 laboratory depending on units attempted. This class is designed to increase flexibility and circulation and promote relaxation by learning various stretching exercises including reciprocals and yoga postures plus breathing and relaxation techniques. May be taken for credit 4 times. Pass/No Pass/Letter Grade Option. (UC Credit Limitation/CSU)

DANC 124 C Partnering 1 Unit

Prerequisite: Demonstrated mastery of intermediate dance level technique.
Term hours: 32–36 laboratory. This class introduces the basic elements of partnering to the intermediate dancer. The students will develop the strength and coordination to perform the basic skills for both floor partnering and lifts. May be taken for credit 4 times. (UC/CSU)

DANC 130 C Afro-Caribbean Dance 1 Unit

Term hours: 32–36 laboratory. Students will learn the dance styles and rhythms of African and Caribbean cultures including dances from West Africa, Brazil, Trinidad, Haiti, Bahia, Cuba, and the Dominican Republic. Dance as an inseparable part of the culture will be discussed. May be taken for credit 4 times. Pass/No Pass/Letter Grade Option. Dance concert admission not to exceed \$30.00. (UC/CSU)

DANC 131 C Ballet Folklorico 1 to 2 Units

Term hours: 32–72 laboratory depending on units attempted. Students will learn folk dances from various regions of Mexico such as Vera Cruz, Jalisco and Pueblo. The cultural background of each dance will be discussed. May be taken for credit 4 times. Pass/No Pass/Letter Grade Option. Cost of dance concert not to exceed \$12.00. (UC/CSU)

DANC 132 C Flamenco Dance 1 to 2 Units

Term hours: 32–72 laboratory depending on units attempted. Students will study basic Flamenco Dance technique and learn movement combinations and the cultural aspect of the dance. The class provides students with the opportunity to develop coordination, rhythm, and performance skills for Flamenco Dance. Some history of Flamenco will be included. May be taken for credit 4 times. Pass/No Pass/Letter Grade Option. Dance concert admission will not exceed \$12.00. (UC/CSU)

DANC 133 C Dance of Andalusia 1 to 2 Units

Term hours: 32–72 laboratory depending on units attempted. Students will study the dance of Andalusia, Spain, dance technique and movement combinations with increasingly difficult rhythmic patterns. May be taken for credit 4 times. Pass/No Pass/Letter Grade Option. Dance concert admission not to exceed \$12.00. (UC/CSU)

DANC 134 C Latin Jazz 1 to 2 Units

Term hours: 32–72 laboratory depending on units attempted. Students will study and learn basic skills of Latin jazz dance and styles inherent in Jazz and Afro-Cuban dance and Latin popular rhythms such as Cha Cha, Mambo, Salsa, Merenque, Bolero, Cumbia, Corridos, and Flamenco Rumba. Students will learn Latin Jazz combinations. May be taken for credit 4 times. Pass/No Pass/Letter Grade Option. Dance Concert admission not to exceed \$30.00. (UC/CSU), AA GE

DANC 136 C Middle Eastern Dance 1 Unit

Term hours: 32–36 laboratory. Students will learn the social and stage dances from the Near and Middle East. Course work includes styling, veil work, cymbal playing, improvisation, Dabke, fusion forms, vocabulary and cultural background of the dances. May be taken for credit 4 times. Pass/No Pass/Letter Grade Option. Dance concert admission not to exceed \$12.00. (UC/CSU)

DANC 137 C Latin and Swing Dance 1 Unit

Term hours: 32–36 laboratory. Students will learn various Latin and swing dance forms such as east and west coast swing, salsa, cha-cha, and meringue. The course will focus on learning the choreography in each style while developing coordination, partnering and performances skills. Individual choreography will enhance the students' knowledge of each dance forms as well as encourage creativity. May be taken for credit 4 times. Pass/No Pass/Letter Grade Option. Dance concert admission not to exceed \$12.00. (UC/CSU)

DANC 139 C Ballroom I 1 Unit

Term hours: 32–36 laboratory. This course gives students the opportunity to learn various ballroom dances. Examples of dance forms that may be included are Waltz, Fox Trot, American Tango and Argentine Tango. The course will focus on learning International and American smooth styles of dance. The students will develop coordination skills and knowledge of each dance form. Course may be taken for credit 4 times. Cost of dance concert admission will not exceed \$30.00. (UC(Pending)/CSU, CSU GE)

DANC 140 C Summer Dance Festival 1 to 1.5 Units

Prerequisite: Audition.

Term hours: 64–108 laboratory TBA depending on units attempted. The Summer Dance Festival is designed to give both high school and college students the opportunity for intensive study of a variety of dance styles by taking technique classes while rehearsing choreography of faculty and students. All phases of the dance concert process from audition to rehearsal to backstage preparation will be covered. May be taken for credit 4 times. (CSU)

DANC 202 C Elements of Choreography 2 Units

Prerequisite: Demonstrated mastery of beginning level dance technique.

Term hours: 32–36 lecture and 16–18 laboratory. Students will study the theories and practices involved in basic dance composition. Methodologies will include elements of shape, space, time, music, topics and other theories and dance styles that involve the creation of a dance. May be taken for credit 4 times. Cost of dance concert admission will not exceed \$30.00. (UC/CSU)

DANC 203 C Dance Production 1 to 2 Units

Term hours: 64–144 laboratory TBA depending on units attempted. This course offers practical experience in the technical aspects of dance production including costume design, set design, makeup, lighting, sound production, and publicity. May be taken for credit 4 times. (UC/CSU)

DANC 204 C Dance Rehearsal and Performance 2 to 3 Units

Prerequisite: Audition.

Advisory: Concurrent Enrollment in one of the following: DANC 203 C, THEA 149 C, or one from THEA 140 C through THEA 147 C.

Term hours: 128–216 laboratory TBA depending on units attempted. This course provides the experience of learning and performing choreographic works of faculty, students, and guest artists. All phases of the dance concert process from audition to rehearsal to backstage preparation will be covered. Dance concert admission may not exceed \$30.00. (UC/CSU)

DANC 205 C Dance Ensemble 3 Units

Prerequisite: Audition.

Term hours: 32–72 laboratory. Theater and dance students with intermediate to advanced skill levels will develop their performing and choreographic skills, learn the basics of fundraising and promotion of dance while performing at K–12 schools, community events and dance festivals. May be taken for credit 4 times. (UC/CSU)

DANC 208 C Pointe Class 1 Unit

Prerequisite: Demonstrated mastery of intermediate dance technique.

Term hours: 32–36 laboratory. Students will learn exercises to develop the strength and coordination to perform ballet steps in pointe shoes. Proper shoe fit, injury prevention and correct body alignment will be covered. May be taken for credit 4 times. Dance concert admission not to exceed \$12.00. (UC/CSU)

DANC 214 C Dance Repertory**2 to 3 Units***Prerequisite: Audition.**Advisory: Concurrent enrollment in one of the following: DANC 203 C, THEA 149 C, or one from THEA 140 C through THEA 147 C.*

Term hours: 128–216 laboratory TBA depending on units attempted. This course provides the opportunity to rehearse and perform works choreographed by faculty and/or artist-in-residence under professional working conditions and requirements. All phases of the dance concert process from audition to rehearsal to backstage preparation will be covered. May be taken for credit 4 times. (UC/CSU)

DANC 215 C Commercial Dance**2 Units***Prerequisite: Demonstrated mastery of intermediate level dance technique.*

Term hours: 64–72 laboratory. Course work will develop the jazz dancer's technique and performance skills in order to successfully execute combinations required for television and musical theater dance performance. May be taken for credit 4 times. Cost of dance concert admission will not exceed \$30.00. (CSU)

DANC 230 C Dance Teaching Methodologies**3 Units***Prerequisite: Demonstrated mastery of intermediate level dance technique.*

Term hours: 32–36 lecture and 32–36 laboratory. Students will learn the appropriate teaching methodologies that can be applied in different instructional venues: schools, colleges and private studios, to name a few. Subject matter will include theoretical and practical applications of dance pedagogy. Cost may not exceed \$30.00 (CSU)

DANC 296 C Dance Open Laboratory**1 to 6 Units**

Term hours: 32–216 laboratory depending on units attempted. This is an open entry/open exit class for students to obtain production experience associated with dance concert through performing, choreographing, technical work, management, and publicity. May be taken for credit 4 times. Open Entry/Open Exit. Concert admission cost may not exceed \$30.00. (UC Credit Limitation/CSU)

DANC 298 C Dance Seminar**.5 to 12 Units***Prerequisite: May be required.**Corequisite: May be required.**Advisory: May be required.*

Term hours: 0–216 lecture and/or 0–864 laboratory depending on units attempted. This seminar provides the opportunity to study new dance styles or a variety of other subject matters related to dance that are not included in present curriculum. May be taken for credit 1–4 times. Pass/No Pass or Pass/No Pass/Letter Grade Option or Standard Letter Grade. Fees may be required — Payable at Registration. (UC Credit Limitation/CSU)

DANC 299 C Dance Independent Study**.5 to 2 Units***Prerequisite: Approved Independent Study Learning Contract.*

Term hours: 16–72 for maximum credit. This course is for advanced students who wish to increase their knowledge of dance and/or performance through individual study or research. Unit credit may range from one-half to two units in any given semester. May be taken for credit 4 times. (UC Credit Limitation/CSU)

Dental Assisting

Division of Health Science

Division Dean — John Sciacca*Faculty*

Elizabeth Pacheco

Counselors

Kelly Carter

Denise Vo

PROGRAM LEARNING OUTCOMES (PLOs)

Dental Assisting

A student who completes the Dental Assisting program will be able to:

- Demonstrate the academic knowledge and skill, and competence necessary to qualify for both the National Certification Exam and the California State Registered Dental Assistant Exam.
- Demonstrate the knowledge necessary for the ethical, legal and competent practice of dental assisting.
- Perform the functions approved by the California Dental Practice Act for a Dental Assistant and Registered Dental Assistant with competence and judgment.
- Attain their dental radiology license.
- Demonstrate clinical competency in Coronal polish and dental sealants.
- Demonstrate laboratory competency in the Ultrasonic removal of excess cement from coronal surfaces of teeth under orthodontic treatment.
- Prepare for employment as a dental assisting as an integral member of the dental team.
- Have the opportunity to explore specialty offices.

REGISTERED DENTAL ASSISTANT

The one-year Registered Dental Assistant (RDA) program includes patient care, experiences in a fully equipped on-site facility, and externship experiences in clinics and dental offices. The Cypress College Dental Assistant program is accredited by the Commission on Dental Accreditation, and has been granted the accreditation status of approval without reporting requirements. The Commission is a specialized accrediting body recognized by the Commission on Recognition of Postsecondary Accreditation and by the United States Department of Education.

The Cypress College Dental Assistant Program is also accredited by the Dental Board of California, the Accrediting body for the dental professionals (Auxiliaries) in California through the Department of Consumer Affairs.

At the completion of the program the student will be certified to take Dental Radiographs “x-rays,” Coronal Polish, Dental Sealant, California Dental Practice Act, Infection Control, CPR and will be eligible to take the California Registered Dental Assistant's Examination and the National Certification Examination for Dental Assistants. Upon successful completion of the California RDA Examination the student will be licensed to perform all of the DA and RDA procedures in California Dental Practice Act.

Registered Dental Assistants are highly valued by the dental professions and have a choice of work environments from private offices to hospitals and clinics. They are involved in a variety of duties including managing the front office, preparing the patient, taking radiographs, mixing dental materials, and now with expanded functions, not only assisting chairside, but performing certain clinical procedures within the patients mouth.

PROGRAM GOALS AND OBJECTIVES

The goals and objectives of the Cypress College Dental Assistant Program are the following:

1. To provide the student with the academic knowledge and skill, and competence necessary to qualify for both the National Certification Exam and the California State Registered Dental Assistant Exam.
2. To prepare the student for dental assisting entry-level employment as an integral member of the dental health team.

THE CYPRESS COLLEGE DENTAL ASSISTANT PROGRAM OBJECTIVES ARE TO:

1. Provide a dental assisting program to meet challenges presented by demographic changes of the current decade.
2. Promote a dental assisting curriculum that helps build student's educational and career goals in a success-oriented learning environment.
3. To provide students with the academic resources and clinical experiences to perform the functions approved by the California Dental Practice Act for a Registered Dental Assistant with competence and judgment.
4. To provide students with academic knowledge and clinical skills in the Dental Practice Act, infection control and CPR.
5. Prepare the student to qualify for certification in Radiology Safety, Coronal Polishing and Dental Sealants.
6. Prepare the student to attain laboratory competency in the ultrasonic removal of excess cement from coronal surfaces of teeth under orthodontic treatment.
7. Maintain a positive communication network between the advisory committee, dental community, and dental assistant program alumni.
8. To create a safe learning environment in compliance with federal and California state standards and regulations.

MINIMUM STANDARD

1. Minimum age of 17 years. (RDA licensure requires candidate to be a minimum age of 18 years).
2. Completion of ENGL 058 C/ESL 185 C or a comparable course, with grade of "C" or better, or submission of test scores that indicate eligibility for ENGL 060 C/ESL 186 C.

APPLICATION PROCEDURES

1. Meet with a counselor to determine fulfillment of the English requirements. Examples of ways to meet these requirements include taking the English assessment test at Cypress or another college and scoring into ENGL 060 C or ESL 186 C, or completing ENGL 058 C or ESL 185 C at Cypress or a comparable course at another college, with a grade of "C" or better.
2. Applications must be completed **online** starting the month of **February**. Applications will be accepted until the program is full or the fall semester begins. Please see the **Health Science Application link** on the Dental Assisting home page.
3. Enrollment is limited to the first 24 qualified applicants.

SELECTION PROCEDURES

Qualified applicants will be accepted into the program first come first serve based on the date of a completed Dental Assisting application and supporting documents.

ASSOCIATE IN SCIENCE DEGREE REGISTERED DENTAL ASSISTING

Program Code: 1S21117

This program is designed to enable a student to receive a Dental Assisting Associate in Science Degree. To earn an Associate Degree students must complete all graduation requirements to include: (1) all major course requirements with a "C" or better; (2) 25 units of General Education Graduation Requirements; (3) the cultural diversity and reading requirements; (4) any elective courses to complete a minimum of 60 units; and, (5) have a minimum GPA of 2.0. At least 50% of all major course work must be completed at Cypress College.

Required Courses are listed in suggested sequence. The following courses must be completed with a minimum grade of "C" to continue in the program.)

Course #	Title	Units
FALL SEMESTER		
DA 016 C	Dental Materials	3
DA 058 C	Clinical Externship I	2
DA 061 C	Oral Anatomy — Dental Assistant	3
DA 062 C	Preventive Dental Health	2
DA 063 C	Chairside Assisting I	3
DA 065 C	Radiology/Dental Assistants	3
		16
SPRING SEMESTER		
DA 059 C	Clinical Externship II	3.5
DA 066 C	Clinical Dental Radiology	1
DA 067 C	Dental Specialties	3
DA 068 C	Chairside Assisting II	3
DA 069 C	Clinical Externship III	2.5
DA 070 C	Dental Office Procedures	2
Total Units		31

All General Education units may be taken prior to enrollment in the program or at the completion of the Certificate Program.

DENTAL ASSISTING CERTIFICATE

Program Code: 1C03786

This program is designed to enable a student to receive a Dental Assisting Associate in Science Degree. To earn an Associate Degree students must complete all graduation requirements to include: (1) all major course requirements with a "C" or better; (2) 25 units of General Education Graduation Requirements; (3) the cultural diversity and reading requirements; (4) any elective courses to complete a minimum of 60 units; and, (5) have a minimum GPA of 2.0. At least 50% of all major course work must be completed at Cypress College.

Course #	Title	Units
FALL SEMESTER		
DA 016 C	Dental Materials	3
DA 058 C	Clinical Externship I	2
DA 061 C	Oral Anatomy — Dental Assistant	3
DA 062 C	Preventive Dental Health	2
DA 063 C	Chairside Assisting I	3
DA 065 C	Radiology/Dental Assistants	3

SPRING SEMESTER		
DA 059 C	Clinical Externship II	3.5
DA 066 C	Clinical Dental Radiology	1
DA 067 C	Dental Specialties	3
DA 068 C	Chairside Assisting II	3
DA 069 C	Clinical Externship III	2.5
DA 070 C	Dental Office Procedures	2
Total Units		31

Dental Assisting (DA)

DA 016 C Dental Materials **3 Units**

Prerequisite: Acceptance into the Dental Assisting Program.

Term hours: 32–36 lecture and 48–54 laboratory. A study of the structure, chemical and physical properties and manipulation of materials used in dentistry will be covered. Laboratory application of dental materials and the relationship of dental materials to the oral environment is included. Emphasis in this course is on specific materials and functions delegated to the registered dental assistant by the State of California. \$85.00 Material Fee — Payable at Registration.

DA 058 C Clinical Externship I **2 Units**

Prerequisite: Acceptance in the Dental Assistant Program.

Term hours: 8–9 lecture and 64–72 laboratory. This is the first in a series of clinical externships. The emphasis is on the beginning level skills and training for the dental assistant. Dental Assistant students will complete clinical rotations in dental offices and/or schools of dentistry. A minimum of eight hours per week will be spent in the clinical setting

DA 059 C Clinical Externship II **3.5 Units**

Prerequisite: Successful completion of first semester Dental Assistant Program and enrollment in all of the second semester courses.

Term hours: 16–18 lecture and 128–144 laboratory. This is the second in a series of clinical externships. The emphasis is on advanced skills and training for the dental assistant. Dental Assistant students will complete clinical rotations in dental offices and/or schools of dentistry. A minimum of eight hours per week will be spent in the clinical setting.

DA 061 C Oral Anatomy/Dental Assistant **3 Units**

Prerequisite: Acceptance in the Dental Assistant Program.

Term hours: 48–54 lecture. This course prepares the student with the basic dental sciences in order to relate and demonstrate dental chairside procedures. Content includes dental anatomy and physiology, oral embryology and oral histology, tooth morphology, and oral pathology related to sterilization, pharmacology, and pain control.

DA 062 C Preventive Dental Health **2 Units**

Prerequisite: Acceptance in the Dental Assistant Program.

Term hours: 32–36 lecture. This course deals with the concepts of dental health and total patient care. This is accomplished by providing instruction and practice of oral hygiene, production of plaque (etiological factors and effective removal of), applied nutrition, and developing a patient education program. In addition, this course covers management of dental and medical emergencies, taking and evaluating a medical/dental history and systemic diseases with dental care implications.

DA 063 C Chairside Assisting I **3 Units**

Prerequisite: Acceptance in the Dental Assistant Program.

Term hours: 32–36 lecture and 48–54 laboratory. This course provides lecture and laboratory instruction in chairside assisting, including history of dentistry, the dental health team, pre-clinical knowledge and entry-level skills for the assistant, advancing to the application of theoretical knowledge, and principles of restorative dentistry. In addition, students will be provided with a thorough knowledge of infection control in the central environment. Principles and fundamentals of infection control, clinical procedures, sterilization and disinfection will be covered. Content and skills will progress in relation to the complexity of the procedures as the student gains practical experience. \$62.00 Material Fee — Payable at Registration.

DA 065 C Radiology/Dental Assistants **3 Units**

Prerequisite: Enrollment in Dental Assistant program or practicing Dental Assistant enrolled in class to meet state certification.

Term hours: 32–36 lecture and 48–54 laboratory. This course covers the didactic, pre-clinical work on mannequins and clinical instruction on patients as required by the California State Practice Act in regard to radiation safety. Upon successful completion of the course, the student will be certified to take x-rays on patients in the dental office. The student will complete 72 (seventy-two) hours of instruction to meet state requirements. \$74.00 Material Fee — Payable at Registration.

DA 066 C Clinical Dental Radiology **1 Unit**

Prerequisite: Enrollment in the Dental Assistant Program.

Term hours: 48–54 clinical laboratory. This course provides advanced clinical instruction on the exposure of intraoral and extraoral radiographs. The bisecting angle technique; paralleling technique; panelpse machine; and adjunct dental radiology aids will be utilized. Emphasis in this course is placed upon the student's performance and demonstrated ability to consistently produce diagnostic radiographs. \$69.00 Material Fee — Payable at Registration.

DA 067 C Dental Specialties **3 Units**

Prerequisite: Enrollment in the Dental Assistant Program and successful completion of all first semester courses.

Term hours: 32–36 lecture and 48–54 laboratory. This course provides instruction in the principles and procedures to function in the specialty area of dentistry: orthodontics, periodontics, endodontics, pediatric dentistry, prosthodontics, and oral surgery. It also provides information and clinical practice in those functions legally delegated to the Dental Assistant and Registered Dental Assistant in the California Dental Practice Act. It includes rules and regulations implemented by the Board of Dental Examiners pertaining to licensure. \$68.00 Material Fee — Payable at Registration.

DA 068 C Chairside Assisting II — Lecture **3 Units**

Prerequisite: Enrollment in the Dental Assistant Program and successful completion of the first semester courses and/or an employed dental assistant.

Term hours: 32–36 lecture and 48–54 laboratory. This course provides instruction in the principles, instrumentation, and procedures to function as a Registered Dental Assistant according to the legal stipulation in the California Dental Practice Act and implemented by the Board of Dental Examiners.

DA 069 C Clinical Externship III **2.5 Units**

Prerequisite: Successful completion of first semester Dental Assistant Program and enrollment in all of the second semester courses.

Term hours: 128–144 laboratory. This is the third in a series of clinical externships. The emphasis is on advanced skills and training for the dental assistant and registered dental assistant. Dental Assistant students will complete clinical rotations in dental offices and/or schools of dentistry. A minimum of eight hours per week will be spent in the clinical setting.

DA 070 C Dental Office Procedures**2 Units***Prerequisite: Acceptance in Dental Assistant Program.*

Term hours: 32–36 lecture. This course is designed to provide instruction, both didactic and practical application, in the skills and responsibilities of a dental administrative assistant. In addition, the students will be trained to use the Dentrix Dental Software program to become knowledgeable in all areas of practice management utilizing the computer. These areas include patient files, charting and treatment planning, appointment scheduling, reports and insurance claim processing. \$5.00 Material Fee — Payable at Registration.

DA 099 C Dental Assisting Independent Study .5 to 2 Units*Prerequisite: Approved Independent Study Learning Contract.*

Term hours: Varying hours of scheduled conferences or clinics per week according to instructor. This course is designed for students with background/experience in Dental Assisting who wish to increase their knowledge and experience in applied areas. Students will participate in independent study on assigned areas under staff supervision. May be taken for credit 4 times. Pass/No Pass/Letter Grade Option.

Dental Hygiene

Division of Health Science*Division Dean* — John Sciacca*Faculty*

Kendra Contreras

Carol Green

Roberta Lawrence

Carol Zakala

Counselors

Kelly Carter

Denise Vo

PROGRAM LEARNING OUTCOMES (PLOs)**Dental Hygiene**

A student who completes the Dental Hygiene program will be able to:

- Gain the knowledge necessary for the ethical, legal, and competent practice of dental hygiene.
- Gain the knowledge for disease prevention and oral health promotion.
- Gain the knowledge that will allow for involvement in community projects.
- Gain the knowledge that will promote professional growth, development, and an appreciation for scholarly activity.
- Gain the knowledge to provide optimal patient care.
- Attain the knowledge, skills, and values necessary to qualify to take the examinations for licensure as a Registered Dental Hygienist, and a professional member of the allied health team.

ASSOCIATE IN SCIENCE DEGREE**DENTAL HYGIENE****Program Code: 1S03787**

The Cypress College Dental Hygiene Program is accredited by the Commission on Dental Accreditation, and has been granted the Accreditation status of approval without reporting. The Commission is a specialized accrediting body recognized by the United States Department of Education and the Council on Higher Education Accreditation. This program offers a curriculum that provides the student with the appropriate academic instruction to achieve eligibility for the National Board of Dental Hygiene Examiners written examination, and the California State Board Examination for licensure as a Registered Dental Hygienist, qualifying the candidate as stipulated in the California Dental Practice Act.

To earn an Associate Degree students must complete all graduation requirements to include: (1) all major course requirements with a “C” or better; (2) 25 units of General Education Graduation Requirements with a “C” or better; (3) the cultural diversity and reading requirements with a “C” or better; (4) any elective courses to complete a minimum of 60 units; and, (5) have a minimum GPA of 2.0. At least 50% of all major course work must be completed at Cypress College.

PROGRAM GOAL

The goal of the Cypress College Dental Hygiene Program is to provide the student with the educational opportunity to attain the knowledge and skills necessary to qualify for licensure as a Registered Dental Hygienist, and a professional member of the allied health team.

PROGRAM OBJECTIVES

1. To educate dental hygiene students in the ethical, legal and competent practice of dental hygiene.
2. To educate dental hygiene students in the areas of disease prevention and oral health promotion.
3. To facilitate dental hygiene students involvement in community projects.
4. To promote professional growth, development, and an appreciation for scholarly activity.
5. To ensure the dental hygiene student provides optimal patient care.

MINIMUM STANDARDS FOR APPLICANTS

1. Eligibility for admission to Cypress College.
2. High school graduation or completion of the General Education Development (GED) test or passing of high school proficiency examination.
3. GPA of 2.5 or higher in all college work completed.
4. Evidence of good physical and mental health as determined by medical examination upon admission to the program and prior to enrollment.
5. Completion of specific science courses with a minimum of “C” grade and overall GPA of 3.0. See list below.
6. Completion of specific general education courses prior to application.

PREREQUISITES

The following courses must be completed with a minimum grade of “C” and an overall GPA of 2.5.

1. Science: All courses must be completed within five years of filing the initial application and with an overall GPA of 3.0. Four courses must be completed prior to application; the remainder must be completed no later than the end of the spring semester prior to enrollment in the fall program.

Required courses are listed in suggested sequence:

Course #	Title	Units
CHEM 101 C	Introduction to Chemistry	5
CHEM 201 C	Basic Organic and Biochemistry	5
BIOL 220 C	Medical Microbiology	4
BIOL 231 C	General Human Anatomy	4
BIOL 241 C	Human Physiology	4
HRC 100 C	Nutrition	3

2. In addition a minimum of three courses of the following related courses must be completed prior to application. All courses must be completed by the end of the spring semester prior to fall enrollment into the program.

PSY 101 C	Introduction to Psychology	3
SOC 101 C	Introduction to Sociology	3
COMM 100 C	Human Communication	3
ENGL 100 C	College Writing	3
	Cultural Diversity	3

ADDITIONAL COURSES

The following courses are required for the Associate Degree must be completed prior to the end of the program if an Associate Degree has not already been earned by the student:

MATH 040 C	Intermediate Algebra (or higher)	4
	Art	3
	Humanities	3
PE	Physical Education	1
	Reading Proficiency	3
	Cultural Diversity	3

SELECTION PROCEDURE

Applications normally exceed capacity. Selection of applicants is based on accumulation of points. Criteria are available in the Health Science Counseling Office. Criteria are subject to change. It is the applicant's responsibility to verify that evidence of criteria is on file at Cypress College.

APPLICATION PROCEDURES

1. Applications must be completed **online** during the month of **February**. Please see the **Health Science Application link** on the Dental Hygiene home page.
2. Applicants must submit official transcripts (except Cypress and Fullerton Colleges) and signature page of application **in person** to the Health Science Applications office, Health Science Building, Cypress College 9200 Valley View Street, Cypress, California 90630-5897 by **March 15**. Please bring photo identification.

DENTAL HYGIENE CURRICULUM

Dental Hygiene courses must be taken in a specific sequence. Students must obtain a minimum grade of “C” or better in all courses listed in the Dental Hygiene Curriculum to continue in the program. Refer to the General Education Requirement of the college to obtain an Associate Degree.

Upon completion of the Dental Hygiene curriculum listed below and the general education requirements, the student will be eligible for an Associate Degree from Cypress College. Those students who have previously earned an Associate Degree and have completed all the Cypress College Dental Hygiene curriculum requirements will be eligible for a Certificate in Dental Hygiene.

Required Courses are listed in specific sequence:

Course #	Title	Units
SEMESTER 1		
DH 101 C	Dental Anatomy and Morphology	2
DH 104 C	Oral Health Assessment	3
DH 106 C	Radiology Tech./Hygienists	3
DH 109 C	Pre-Clinical Dental Hygiene	4.5
DH 205 C	Oral Histology and Embryology	3
Total Units Required		15.5

SEMESTER 2		
DH 110 C	Clinical Dental Hygiene	6
DH 113 C	General and Oral Pathology	2
DH 116 C	Dental Materials/Hygienists	2
DH 125 C	Perio Pathology and Therapy	2
DH 212 C	Head and Neck Anatomy	2
Total Units Required		14

SEMESTER 3		
DH 220 C	Clinical Dental Hygiene	6
DH 240 C	Community Oral Health I	2
DH 250 C	Pharmacology	2
DH 255 C	Dental Anesthesiology	2
DH 260 C	Dental Care for Special Needs	2
Total Units Required		14

SEMESTER 4		
DH 221 C	Clinical Dental Hygiene	6
DH 230 C	Dental Specialties	2
DH 241 C	Community Oral Health II	2
DH 245 C	Dental Jurisprudence	2
DH 248 C	Medical/Dental Emergencies	1
Total Units Required		13

Program Total Units 56.5

Electives

DH 275 C	Clinical Dental Hygiene	.5
DH 299 C	Dental Hygiene Independent Study	.5–2

DENTAL HYGIENE CERTIFICATE

Program Code: 1C21118

Students who have previously earned an Associate of Science or higher degree and have completed all the Cypress College Dental Hygiene curriculum requirements will be eligible for a Certificate in Dental Hygiene. To earn a certificate, students must complete the required courses as listed with a minimum grade of “C.” At Least 50% of all course work must be completed at Cypress College.

PRE-DENTAL HYGIENE TRANSFER PROGRAM

Students should consult a counselor or www.assist.org for lower division major requirements for most California public universities. (See the Standard Definitions section of the catalog for a description of ASSIST.) Students transferring to an independent college/university should consult the catalog of the individual school and a counselor for lower division major requirements.

Dental Hygiene (DH)

DH 101 C Dental Anatomy and Morphology 2 Units

Prerequisite: Admission to and enrollment in the Dental Hygiene Program.
Term hours: 32–36 lecture. This course presents a study in dental anatomy, morphology, and occlusion essential to the proper care of patients during clinical treatment. An emphasis will be placed on the proper identification of oral and dental structures, the utilization of proper terminology, the recognition of normal occlusion in contrast to malocclusion and the clinical significance of temporomandibular joint dysfunction. (CSU)

DH 104 C Oral Health Assessment 3 Units

Prerequisite: Admission to and enrollment in the Dental Hygiene Program.
Term hours: 48–54 lecture. This course is a multifaceted course that presents foundation information skills for the beginning student clinician to utilize daily in direct patient care. Primarily, it is an introduction to the recognition, gathering and interpretation of assessment data as an aid to formulating checklist dental hygiene treatment plans. In addition, it provides the basics to dental disease prevention through the dissemination and application of existing dental health knowledge through chair side instruction. (CSU)

DH 106 C Radiology Tech./Hygienists 3 Units

Prerequisite: Admission to and enrollment in the Dental Hygiene Program.
Term hours: 32–36 lecture and 48–54 laboratory. This course for dental hygiene students includes didactic and preclinical instruction in the essential of dental radiography. Lecture emphasizes the technical aspects of radiation production, protection against the hazards of radiation, and utilization of radiographs during patient care. The laboratory provides demonstrations and practical application in the fundamentals of intraoral and extraoral radiographic techniques, processing, mounting and identification of normal anatomical landmarks. \$66.00 Material Fee — Payable at Registration. (CSU)

DH 109 C Pre-Clinical Dental Hygiene 4.5 Units

Prerequisite: Admission to and enrollment in the Dental Hygiene Program.
Term hours: 40–45 lecture and 96–108 laboratory. This is the first in a series of four courses designed to prepare the student for clinical dental hygiene practice. Content emphasis includes maintenance of aseptic technique/infection control, care and operation of dental equipment, identification and purpose and function of basic instrumentation skills, instrument sharpening, polishing agents and methods, topical fluoride application, entry level clinic forms and procedures, clinic duties, and clinical practice utilizing examination procedures and basic instrumentation techniques on student patient partners and periodontal tyodonts/manikins. \$63.00 Material Fee — Payable at Registration. (CSU)

DH 110 C Clinical Dental Hygiene 6 Units

Prerequisite: Enrollment in the Dental Hygiene Program and successful completion of all first semester courses.
Term hours: 16–18 lecture and 48–54 laboratory and 192–216 clinic per week. This is the second in a series of four courses designed to prepare the student for clinical dental hygiene practice. Emphasis is placed on perfecting oral inspection and medical/dental health history documentation, and developing dental hygiene treatment plans. Additional course content includes: introduction to universal curett instrumentation and sharpening techniques, root debridement techniques, oral and subgingival irrigation, gingival curettage, introduction to ultrasonic instrumentation and air polishing. Clinical skills will be demonstrated and evaluated on clinical patients appointed in the Cypress College Dental Hygiene Clinic. (CSU)

DH 113 C General and Oral Pathology 2 Units

Prerequisite: Enrollment in the Dental Hygiene Program and successful completion of all first semester courses.
Term hours: 32–36 lecture. This course introduces students to concepts of oral pathology and specific pathologic processes, including inflammatory and immunologic defenses, as well as neoplastic, metabolic, inherited and developmental disturbances. A summary of each condition is presented and includes information to aid the Dental Hygienist in developing a clinically useful differential diagnosis. (CSU)

DH 115 C Nutrition for Dental Hygiene 2 Units

Prerequisite: Current enrollment in the Dental Hygiene Program and successful completion of first semester courses.
Term hours: 32–36 lecture. This course is designed to provide knowledge in nutrition and biochemistry. Instruction will emphasize the principles of nutrition, their application to dental health instruction, nutritional counseling, dental survey, and patient nutritional assessment. (CSU)

DH 116 C Dental Materials/Hygienists 2 Units

Prerequisite: Enrollment in the Dental Hygiene Program and successful completion of all first semester courses.
Term hours: 16–18 lecture and 48–54 laboratory. The structure, chemical and physical properties, and manipulation of materials used in dentistry will be covered. Laboratory application of dental materials and the relationship of dental materials to the oral environment is included. Emphasis will be placed on specific materials and functions delegated to the registered dental assistant and dental hygienist by the State of California. \$25.00 Material Fee — Payable at Registration. (CSU)

DH 125 C Perio Pathology and Therapy 2 Units

Prerequisite: Enrollment in the Dental Hygiene Program and successful completion of all first semester courses.
Term hours: 32–36 lecture. This course is designed to provide the dental hygiene student with current theory in periodontics. The healthy periodontium as well as the diseased states will be explored. New surgical concepts and techniques in periodontics will be discussed. The management of periodontics in clinical treatment will be emphasized. (CSU)

DH 205 C Oral Embryology and Histology 3 Units

Prerequisite: Admission to and enrollment in the Dental Hygiene Program.
Term hours: 32–36 lecture and 48–54 laboratory. This course is an introduction to the microscopic characteristics of the tissues, histology, and embryology of the head and neck with an emphasis of the structure of the oral cavity. (CSU)

DH 212 C Head and Neck Anatomy 2 Units

Prerequisite: Enrollment in the Dental Hygiene Program and successful completion of all first semester courses.
Term hours: 32–36 lecture. This course is a study of the gross and anatomical structures of the head and neck. The relationship and function of the organs of the head and neck in the human body are studied, with an emphasis on structures and innervations of the oral cavity. (CSU)

DH 220 C Clinical Dental Hygiene 6 Units

Prerequisite: Enrollment in the Dental Hygiene Program and successful completion of all second semester courses.

Term hours: 16–18 lecture and 256–288 laboratory. This is the third in a series of four courses designed to prepare the student for clinical dental hygiene practice. Lecture and clinical instruction will be applied by experience on clinical patients in the Cypress College Dental Hygiene facility and off campus clinical site, and/or an enriching facility. An emphasis will be placed on the assimilation and utilization of previous instruction and demonstration of progressive learning. This course also emphasizes the performance of those expanded duties in dental hygiene as allowed by the California State Dental Practice Act and the progressive development of professional and managerial skills. \$23.00 Materials Fee — Payable at Registration. (CSU)

DH 221 C Clinical Dental Hygiene 6 Units

Prerequisite: Enrollment in the Dental Hygiene program and successful completion of all third semester courses.

Term hours: 16–18 lecture and 256–288 laboratory. This is the final course in clinical dental hygiene designed to prepare the student for clinical dental hygiene practice and to provide students advanced instruction in patient care. Lecture and clinical instruction will be applied by clinical experience on clinical patients in the Cypress College Dental facility and off campus clinical site, and/or an enriching facility. An emphasis will be placed on: (1) periodontal therapy, (2) supportive periodontal treatment, (3) expanded and supportive periodontal treatment, (4) expanded and supportive procedures, (5) treatment planning, (6) organization and implementation of a Student Research presentation/Table Clinic, and (7) the completion and presentation of a Case Presentation of extensive and comprehensive dental hygiene treatment of a patient. (CSU)

DH 230 C Dental Specialties 2 Units

Prerequisite: Enrollment in the Dental Hygiene Program and successful completion of all third semester courses.

Term hours: 32–36 lecture. This is a study of the dental hygienist's role within the various dental practices. Each dental specialty practice is studied to establish a proper perspective of dental hygiene in relationship to dentistry and to have a greater comprehension of total patient care. (CSU)

DH 240 C Community Oral Health I 2 Units

Prerequisite: Enrollment in the Dental Hygiene program and successful completion of all second semester courses.

Term hours: 32–36 lecture. This is the first of two courses designed to provide the student with the knowledge and experience necessary to work within the community in the area of public health. Emphasis will be placed on the understanding of developing a community health project, use of statistics, and the development of teaching strategies for use in the classroom. Students are expected to work with target groups within the community. (CSU)

DH 241 C Community Oral Health II 2 Units

Prerequisite: Enrollment in the Dental Hygiene Program and successful completion of all third semester courses.

Term hours: 32–36 lecture. This course is the second of two courses in Community Oral Health to develop principles and practices of dental public health. Emphasis of instruction will be placed on community-wide problems such as water fluoridation and the delivery of care. Students will participate in target groups within the community. (CSU)

DH 245 C Dental Jurisprudence 2 Units

Prerequisite: Enrollment in the Dental Hygiene Program and successful completion of all third semester courses.

Term hours: 32–36 lecture. This course offers a study of the fundamental factors necessary to conduct a well-regulated practice based on sound dental management principles within the legal and ethical framework of the State Dental Practice Act. Emphasis is placed on the historical aspects of dental hygiene, the ethical and legal responsibilities of the dental hygienist, interpersonal relations among members of the dental team, and patient-office relationships. (CSU)

DH 248 C Medical/Dental Emergencies 1 Unit

Prerequisite: Enrollment in Dental Hygiene Program and successful completion of all third semester courses.

Term hours: 16–18 lecture. This course will provide the student with a consolidation of information concerning medical/life threatening situations within the dental care setting. Early recognition of clinical signs and symptoms and emergency treatment of the condition will be included in this course. (CSU)

DH 250 C Pharmacology 2 Units

Prerequisite: Enrollment in the Dental Hygiene Program and successful completion of all second semester courses.

Term hours: 32–36 lecture. This course includes the principles of drug interaction with living tissue (pharmacodynamics) and the time course of drugs within living organisms (pharmacokinetics); drug effects on the cardiovascular, autonomic, and central nervous systems; drug management of anxiety, pain and infection as related to dental practice and the harmful aspects of drugs (toxicology). (CSU)

DH 255 C Dental Anesthesiology 2 Units

Prerequisite: Enrollment in the Dental Hygiene Program and successful completion of all second semester courses.

Term hours: 16–18 lecture and 48–54 laboratory. This course includes the theory and techniques of administration of local anesthesia and sedation in dentistry as related to the State Dental Practice Act. The student will administer local anesthesia and nitrous oxide-oxygen sedation in the clinical setting as a component of comprehensive patient care. (CSU)

DH 260 C Dental Care for Special Needs 2 Units

Prerequisite: Enrollment in the Dental Hygiene Program and successful completion of all second semester courses.

Term hours: 32–36 lecture. This course is designed to give the student a study in the needs of the medically compromised, or the mentally and physically challenged patient. Emphasis will be placed on therapeutic techniques in treating these special needs patients in a dental clinical situation. (CSU)

DH 275 C Clinical Dental Hygiene .5 Units

Prerequisite: DH 110 C.

Term hours: 24–27 laboratory. This is a clinical course in dental hygiene designed to provide students advanced instruction in patient care. An emphasis will be placed on treatment planning, and clinical instrumentation. This course provides the student with 24 hours of clinical instruction. May be taken for credit 3 times. Pass/No Pass only. (CSU)

DH 299 C Dental Hygiene Independent Study .5 to 2 Units

Prerequisite: Approved Independent Study Learning Contract.

Term hours: 8–36 lecture and/or 0–108 laboratory depending on units attempted. This course is designed for students enrolled in the Dental Hygiene Program who wish to increase their knowledge and experience in applied areas. Students will participate in independent study on assigned areas under staff supervision. May be taken for credit 3 times. Pass/No Pass/Letter Grade Option. (CSU)

Dentistry

DENTISTRY TRANSFER PROGRAM

Professional programs such as dentistry, medicine, pharmacy, optometry, physician assistant, physical therapy and veterinary medicine are most often graduate programs that require a bachelor degree or significant preparation prior to entering the program. The appropriate preparation varies according to the school and specific program. Students are advised to meet with a counselor to discuss options for their bachelor degree and the lower division requirements for the program and school of their choice.

Diagnostic Medical Sonography

Division of Health Science

Division Dean — John Sciacca

Faculty

Nancy Corrales

Lynn Mitts

Counselors

Kelly Carter

Denise Vo

PROGRAM LEARNING OUTCOMES (PLOs)

Diagnostic Medical Sonography Program Goals

1. Students will have the knowledge and skills to competently and safely perform sonography procedures.
2. Students will develop the skills necessary to communicate effectively.
3. Students will use critical thinking and problem solving skills.
4. Students will evaluate the importance of professional development and growth.
5. The program will provide the community with entry level sonographers for employment in the healthcare setting.

DIAGNOSTIC MEDICAL SONOGRAPHY PROGRAM

PROGRAM MISSION STATEMENT

The Cypress College Diagnostic Medical Sonography program provides a high quality education to prepare a diverse population of students with entry level skills needed to become competent and confident sonographers.

PROGRAM GOALS

1. Students will have the knowledge and skills to competently and safely perform sonography procedures.
2. Students will develop the skills necessary to communicate effectively.
3. Students will use critical thinking and problem solving skills.
4. Students will evaluate the importance of professional development and growth.

5. The program will provide the community with entry level sonographers for employment in the healthcare setting.

Program Effectiveness expected outcomes are:

- a. Students will pass the national certification exam on the 1st attempt.
- b. Students seeking employment will be gainfully employed within 6 months of graduation.
- c. Students will complete the program.
- d. Graduates will be satisfied with their education.
- e. Employers will be satisfied with the performance of newly hired technologists.

After completing the clinical internship and receiving the completion certificate, the student will be eligible to apply for the certification examination administered by the American Registry of Diagnostic Medical Sonographers (ARDMS). The Diagnostic Medical Sonography program is accredited by the Joint Review Committee for Diagnostic Medical Sonographers (JRC-DMS) and the Commission on Accreditation of Allied Health Education Programs.

JRC-DMS

2025 Woodlane Drive

St. Paul, MN 55125-2998

(651) 731-1582 www.jrcdms.org

MINIMUM STANDARDS TO APPLY

1. Eligibility for admission to Cypress College.
2. High school diploma or GED test, or the high school proficiency examination.
3. Minimum age of 17 years.
4. Present evidence of good physical and mental health, as determined by medical examination upon admission to program and prior to enrollment.
5. Overall GPA of 2.0 in all college classes taken.
6. Must have own transportation to all affiliated hospitals.
7. Eligibility for ENGL 100 C.
8. See "Prerequisites and Requirements" for specific course prerequisites needed to apply.

PREREQUISITES AND REQUIREMENTS

1. The following *Foundation* courses must be completed by the end of the spring semester with a minimum "C" grade in each course. Any course with a grade lower than a "C" may only be repeated twice.

Course #	PREREQUISITES Title	Units
RADT 142 C	Radiologic Electronics	4
RADT 153 C	Radiography Patient Care	3
HS 145 C	Survey of Medical Terminology	3
HS 147 C	Survey of Disease	3
BIOL 210 C	Anatomy and Physiology	5
ENGL 100 C	College Writing	(3)
	or	
COMM 050 C	Effective Oral Communication	(3)
	or	
COMM 100 C	Human Communication	(3)
MATH 040 C	Intermediate Algebra	4
CIS 111 C	Computer Information Systems	3
*DMS 060 C	Medical Sonography Theory	2

2. *DMS 060 C must be completed in the Summer session prior to enrollment into the Fall Semester of the Sonography Program.

APPLICATION AND SELECTION PROCEDURE

1. A separate application, in addition to the college application, is required for admission into the Diagnostic Medical Sonography Program.
2. Applications must be completed **online** during the month of **February**. Please see the **Health Science Application link** on the Diagnostic Medical Sonography home page.
3. Applicants must submit official transcripts (except Cypress and Fullerton Colleges), documents (AART, CRT, Certificate and signature page of application) **in person** to the Health Science Applications office, Health Science Building, Cypress College 9200 Valley View Street, Cypress, California 90630-5897 by **March 15**. Please bring photo identification.
4. Practical Radiologic Technology years of experience must be verified by completion of the work experience form by the employer, if applicable.
5. An appointment with Health Science counselor or attendance at a program information meeting is recommended to discuss selection criteria and deadlines for application process. Selection criteria will award points to practical and formal radiologic technology experience as well as grade point average in program prerequisites. Selection criteria is subject to change.
6. Class enrollment is based on the number of approved clinical education centers available. Student capacity is also determined by the Joint Review Commission in Diagnostic Medical Sonographers.

ASSOCIATE IN SCIENCE DEGREE DIAGNOSTIC MEDICAL SONOGRAPHY

Program Code: 1C07840

The Department of Radiologic Technology will provide occupational training in ultrasound/medical sonography. The purpose of this instruction is to qualify the student for examination by the American Registry of Diagnostic Medical Sonography and to prepare the student for gainful employment in ultrasound/medical sonography.

To earn an Associate Degree students must complete: (1) all major course requirements with a minimum grade of "C"; (2) 25 units of General Education Graduation Requirements; (3) the cultural pluralism and reading requirements; (4) any elective courses to complete a minimum of 60 units; and (5) have a minimum GPA of 2.0. At least 50% of all major course work must be completed at Cypress College.

Required courses:	Units
All courses of the Certificate Program	53
General Education Graduation Requirements	25
Total Units Required	78

Note: All General Education Graduation Requirements units may be taken prior to enrollment in the program or at the completion of the Certificate Program.

REQUIREMENTS

SEMESTER I		Units
DMS 170 C	Sonography Physics	3
DMS 175 C	Abdomen Scanning	4
DMS 172 C	Sonography Externship	5
RADT 262 C*	Cross-Sectional Imaging	1
HS 165 C*	Ethical Choices in Health Care	1.5
SEMESTER II		Units
DMS 176 C	Pathology and Small Parts	3
DMS 186 C	OB/GYN Sonography	4
DMS 207 C	Clinical Education I	10

SUMMER INTERSESSION		Units
DMS 188 C	Doppler Techniques	1.5
DMS 217 C	Clinical Education II	7
SEMESTER III		Units
DMS 227 C	Clinical Education III	11
DMS 210 C	Sonography Review	2
Total Units		53

*May be taken prior to enrollment in the program.

DIAGNOSTIC MEDICAL SONOGRAPHY CERTIFICATE

Program Code: 1C21115

REQUIREMENTS

SEMESTER I		Units
DMS 170 C	Sonography Physics	3
DMS 175 C	Abdomen Scanning	4
DMS 172 C	Sonography Externship	5
RADT 262 C*	Cross-Sectional Imaging	1
HS 165 C*	Ethical Choices in Health Care	1.5
SEMESTER II		Units
DMS 176 C	Pathology and Small Parts	3
DMS 186 C	OB/GYN Sonography	4
DMS 207 C	Clinical Education I	10
SUMMER INTERSESSION		Units
DMS 188 C	Doppler Techniques	1.5
DMS 217 C	Clinical Education II	7
SEMESTER III		Units
DMS 227 C	Clinical Education III	11
DMS 210 C	Sonography Review	2
Total Units		53

*May be taken prior to enrollment in the program.

Diagnostic Medical Sonography (DMS)

DMS 060 C Introduction to Sonography 2 Units

Prerequisite: Satisfactory completion of RADT 142 C, RADT 153 C, HS 145 C, HS 147 C, BIOL 210 C, ENGL 100 C, MATH 040 C and CIS 111 C all with minimum grades of "C."

Term hours: 24–27 lecture and 24–27 laboratory. This course is designed for the student entering the sonography program. Basic sonography theory is taught with emphasis on sonographic terminology and equipment manipulation. Anatomy identification, scanning planes, transducer orientation, ergonomics, and scanning protocols are included. Non-Degree Credit. May be taken for credit 4 times. Pass/No Pass/Letter Grade Option. \$14.00 Material Fee — Payable at Registration.

DMS 170 C Sonography Physics 3 Units (formerly RADT 170 C and RADT 173 C)

Prerequisite: Admission into the Diagnostic/Medical Sonography Program and a minimum grade of "C" in RADT 142 C, MATH 040 C, CIS 111 C, DMS 060 C, HS 147 C, and completion of or concurrent enrollment and a minimum grade of "C" in HS 165 C and RADT 262 C.

Corequisite: DMS 175 C and DMS 172 C.

Term hours: 48–54 lecture. This course will provide lecture and demonstrations covering the areas of acoustical physics, propagation principles, transducers, machine instrumentation, hemodynamics, harmonics, doppler principles, biological effects, artifacts, and quality control. (CSU)

DMS 172 C Sonography Externship 5 Units

Prerequisite: Admission into the Diagnostic Medical Sonography Program and DMS 060 C, CIS 111 C, ENGL 100 C, COMM 050 C, BIOL 210 C, HS 145 C, HS 147 C, RADT 153 C, RADT 142 C, MATH 040 C with minimum grades of "C." Completion of or concurrent enrollment in RADT 262 C or HS 165 C with a minimum grade of "C."
Corequisite: DMS 170 C and DMS 175 C.

Term hours: 256–288 laboratory TBA. This course is designed to acclimate the sonography student to the hospital setting, sonography department, and the sonography profession. The student is expected to complete a minimum of 256 hours of clinical training at an assigned clinical facility. Topics include hospital orientation, HIPPA regulations, SDMS code of ethics, sonography ergonomics, and basic scanning techniques and protocols. (CSU)

DMS 175 C Abdomen Sonography 4 Units

Prerequisite: Admission into the Diagnostic/Medical Sonography Program and minimum grades of "C" in RADT 142 C, RADT 153 C, HS 145 C, HS 147 C, BIOL 210 C, COMM 050 C, ENGL 100 C, CIS 111 C, MATH 040 C, and DMS 060 C. Completion of or concurrent enrollment and a minimum grade of "C" in RADT 262 C and HS 165 C.
Corequisite: DMS 170 C and DMS 172 C.

Term hours: 48–54 lecture and 24–27 hours laboratory. This course will provide a study of the clinical applications of abdomen sonography. It will include abdominal vasculature; liver; gallbladder and biliary system; pancreas; spleen; and kidneys. Interpretation of clinical laboratory tests, related clinical signs and symptoms, and normal and abnormal sonographic patterns will be discussed. This course includes a lab section on basic scanning techniques and protocol. (CSU)

DMS 176 C Pathology and Small Parts 3 Units

Prerequisite: DMS 175 C, RADT 262 C, DMS 170, DMS 172 C and HS 165 C with minimum grades of "C."
Corequisite: DMS 186 C and DMS 207 C.

Term hours: 48–54 lecture. This course will discuss the manifestations of abdominal pathology and disease conditions and their relevance to sonographic procedures including hemodynamic changes. The student will describe abdomen scanning techniques and procedures appropriate for the disease process. Normal anatomy, scanning technique, and pathology of small parts is included as well as neonatal imaging. The course will support the student in the clinical phase of sonographic training. Sonographic technique and actual pathologic cases will be discussed. (CSU)

DMS 186 C Ob/Gyn Sonography 4 Units

Prerequisite: DMS 170 C, RADT 262 C, DMS 175 C, DMS 172 C, and HS 165 C with minimum grades of "C."
Corequisite: DMS 176 C and DMS 207 C.

Term hours: 64–72 lecture. Obstetric/Gynecology sonography is a study of the pregnant and non-pregnant female reproductive system. This includes an assessment of fetal gestational age, fetal anatomy and pathology, as well as associated maternal conditions. Gynecological sonography includes normal female anatomy along with pathological processes. Topics of discussion include related clinical symptoms, sonographic appearances, scanning techniques and protocols, and laboratory tests. This course includes a demonstration section on basic scanning techniques and protocol. (CSU)

DMS 188 C Doppler Techniques 1.5 Units

Prerequisite: DMS 176 C, DMS 186 C, and DMS 207 C with minimum grades of "C."
Corequisite: DMS 227 C.

Term hours: 24–27 lecture. This course includes vascular scanning techniques related to carotid, venous, and arterial sonographic exams. Pass/No Pass/Letter Grade Option. (CSU)

DMS 207 C Clinical Education — I 10 Units

Prerequisite: DMS 172 C, DMS 175 C, RADT 262 C, HS 165 C and DMS 170 C with minimum grades of "C."
Corequisite: DMS 176 C and DMS 186 C.

Term hours: 480–540 laboratory TBA. This course is a minimum of 480 hours of clinical experience at an affiliated hospital/medical center. This course will provide basic instruction and scanning experiences in abdomen sonography. The student will be able to demonstrate the ability to perform sonographic examinations of the abdomen according to the protocols established by the program and clinical education center utilizing sonographic equipment. (CSU)

DMS 210 C Review Seminar 2 Units

Prerequisite: Satisfactory completion of DMS 188 C and DMS 217 C with a minimum grade of "C."
Corequisite: DMS 227 C.

Term hours: 32–36 lecture. This course will prepare the student to enter the workforce by combining all skills acquired during didactic and clinical training. This course correlates and analyzes information pertaining to ultrasound case studies. The student will achieve an in depth comprehension and an increased level of understanding of clinical symptoms, sonographic patterns, alternative imaging procedures, and technical pitfalls associated with a diagnostic ultrasound exam. Review of abdomen, small parts, physics, obstetric and gynecology will be included to help prepare the student for the American Registry of Diagnostic Medical Sonography test. (CSU)

DMS 217 C Clinical Education II 7 Units

Prerequisite: DMS 207 C, DMS 176 C and DMS 186 C all with minimum grades of "C."
Corequisite: DMS 188 C.

Term hours: 352–396 laboratory TBA. This course requires a minimum of 384 hours of clinical experience at an affiliated hospital/medical center. This course will provide basic instruction and scanning experiences in breast, thyroid, scrotum, and doppler sonography. The student will be able to demonstrate the ability to perform sonographic examinations of small parts according to the protocols established by the program and clinical education center utilizing sonography equipment. (CSU)

DMS 227 C Clinical Training III 11 Units

Prerequisite: DMS 188 C and DMS 217 C with minimum grades of "C."
Corequisite: DMS 210 C.

Term hours: 536–603 laboratory. This course requires a minimum of 544 hours of clinical training at an affiliated hospital/medical center. This course will provide the basic instruction and scanning experiences in obstetrics and gynecology sonography. The student will be able to demonstrate the ability to perform sonographic examinations of the gravid and non-gravid pelvis according to the protocols established by the program and clinical education center utilizing sonography equipment with both transabdominal and endocavity transducers. (CSU)

**Drafting — See
Engineering Technology (ENGT)**

Economics

Division of Social Sciences

Division Dean — Nina DeMarkey

Faculty

Fola Odebunmi
Parwinder Sidhu

Counselors

Velia Lawson
Therese Mosqueda-Ponce
Daniel Pelletier

PROGRAM LEARNING OUTCOMES (PLOs)

The courses taught by this department contribute to the General Education and Basic Skills Program Learning Outcomes. Please refer to General Education and Basic Skills Program Learning Outcomes.

BUSINESS ECONOMICS CERTIFICATE

Program Code: 1K17172

Combining economics principles with business practices, this certificate program provides students with the necessary knowledge to make informed financial decisions. Students will gain an understanding of supply and demand and resource allocation issues, marketplace competitive factors, consumer purchasing patterns, and money-management and investment strategies.

To earn a certificate, students must complete the required courses as listed with a minimum grade of “C.” At least 50% of all course work must be completed at Cypress College.

Required courses are listed in suggested sequence:

Course #	Title	Units
ECON 105 C	Principles of Economics — Micro or	3
ECON 105HC	Honors Principles of Economics	(3)
MGT 161 C	Introduction to Business	3
ECON 130 C	Consumer Economics or	3
MKT 210 C	Consumer Behavior	(3)
MGT 101 C	Personal Finance or	3
MGT 102 C	Financial Literacy	(3)
Total Units Required		12

ECONOMICS TRANSFER PROGRAM

Students should consult a counselor or www.assist.org for lower division major requirements for most California public universities. (See the Standard Definitions section of the catalog for a description of ASSIST.) Students transferring to an independent college/university should consult the catalog of the individual school and a counselor for lower division major requirements.

Economics (ECON)

ECON 100 C Principles of Economics — Macro 3 Units

Prerequisite: MATH 040 C with a minimum grade of “C.”

Term hours: 48–54 lecture. The course concentrates on macroeconomics analysis. Topics emphasized are aggregate supply/demand concepts, economic aggregates and the overall functioning of the American economy, with special emphasis on the role of the government. The course includes national income accounting, employment theory, business cycles, fiscal and monetary policy and economic growth. Duplicate credit not granted for ECON 100HC. (UC Credit Limitation/CSU, AA GE, CSU GE, IGETC)

ECON 100HC Honors Principles of Economics 3 Units

Prerequisite: MATH 040 C with a minimum grade of “C.”

Term hours: 48–54 lecture. This course is an enhanced study of macroeconomics, focusing on the structure and operation of the American economy. Special topics include simulated practice of fiscal and monetary policy, and web-site updates of statistical economics. Duplicate credit not granted for ECON 100 C. (UC Credit Limitation/CSU, AA GE, CSU GE, IGETC)

ECON 105 C Principles of Economics — Micro 3 Units

Prerequisite: MATH 040 C with a minimum grade of “C.”

Term hours: 48–54 lecture. This course concentrates on microeconomic analysis. Topics emphasized are basic structure of the United States economic system, and interrelationships within this structure. The course includes a study of supply and demand, price determination, the market models, resource pricing and allocation, comparative economic systems, and foreign trade/exchange analysis. Duplicate credit not granted for ECON 105HC. (UC Credit Limitation/CSU, AA GE, CSU GE, IGETC)

ECON 105HC Honors Principles of Economics 3 Units

Prerequisite: MATH 040 C with a minimum grade of “C.”

Term hours: 48–54 lecture. This course is an enhanced study of microeconomics analysis with special attention given to web-based interactive material on topics such as: price determination; the market models; comparative economic analysis; and international trade and finance. Duplicate credit not granted for ECON 105 C. (UC Credit Limitation/CSU, AA GE, CSU GE, IGETC)

ECON 110 C Survey of Economics 3 Units

Term hours: 48–54 lecture. This course is a survey of the American Economic System using basic economic concepts to explain a wide variety of economic applications. It includes production and cost, competition and market structure, market failure and externalities, and the labor market as the microeconomic topics. As macroeconomic topics, it includes national income, unemployment and inflation. It also discusses the economic growth and economic fluctuations issues, Monetary and fiscal policy, and international trade and finance. Economics 110 C does not meet the course requirement for majors in economics and business administration. (No UC credit if taken after ECON 100 C/100HC or ECON 105 C/105HC. UC Credit Limitation/CSU, AA GE, CSU GE, IGETC)

ECON 130 C Consumer Economics 3 Units

Term hours: 48–54 lecture. This course explains why and how students as consumers can help shape the market place. It includes personal finance topics such as credit, saving, investment, taxes, consumer responsibilities, influence of advertising, issues on health and wellness, issues of identity theft and fraud. Consumer issues, ethics and globalization will also be emphasized. Economics 130 C does not meet the course requirement for majors in economics and business administration. (CSU)

ECON 260 C Economic Geography**3 Units**

Same as GEOG 260 C.

Term hours: 48–54 lecture. Investigation and interpretation of the world's economic organization, its natural resources, raw material, crop and crop production, manufacturing and service industries, new trends in producing, and the changing centers of production and consumption are covered in this course. (UC/CSU, CSU GE, IGETC)

ECON 298 C Economics Seminar**.5 to 12 Units***Prerequisite: May be required.**Corequisite: May be required.**Advisory: May be required.*

Term hours: 0–216 lecture and/or 0–432 laboratory depending on units attempted. This is a lecture/discussion type course developed on a particular limited problem or topic of interest to students. It is designed for able students who wish to increase their knowledge of a particular topic concerning which no other regular class is offered. A paper or group activity may be requested. Credit may range from .5 units to 12 units. Consult class schedule for the offerings in a particular semester. May be taken for credit 1–4 times. Pass/No Pass or Pass/No Pass/Letter Grade Option or Standard Letter Grade. Fees may be required — Payable at Registration. (UC Credit Limitation/CSU)

ECON 299 C Economics Independent Study**1 Unit***Prerequisite: Approved Independent Study Learning Contract.*

Term hours: Varying hours of scheduled conferences per week according to instructor. Independent study is for able students who wish to extend their knowledge of a particular area through individual research and study. It is thought that topics might develop out of a curiosity stimulated in a regular class. The student would then contact the supervising instructor to develop a contract for his/her particular interest so that they could learn more regarding their special topic. May be taken for credit 3 times. (UC Credit Limitation/CSU)

Education

Division of Social Sciences

Division Dean — Nina DeMarkey*Counselors*

Velia Lawson

Therese Mosqueda-Ponce

Daniel Pelletier

THE PARAPROFESSIONAL IN EDUCATION CERTIFICATE

Program Code: 1A16915

This certificate will provide qualified personnel with specialized expertise to assist in classrooms and in the community, that support populations labeled with disabilities. It will help school districts meet federal requirements for Paraprofessionals already hired, and future teachers. Vocational and academic coursework are integrated into a lower division Certificate program that will satisfy paraprofessional requirements as well as those needed for an AA Degree and transfer to university credential programs.

To earn a certificate, students must complete the required courses as listed with a minimum grade of "C." At least 50% of all course work must be completed at Cypress College.

Required courses are listed in suggested sequence:

Course #	Title	Units
PSY 139 C	Developmental Psychology	3
	or	
PSY 240 C	Child Development and Education	(3)
HUSR 200 C	Introduction to Human Services	3
EDU 204 C	Intro to Special Education	3
EDU 208 C	Children With Disabilities	3
EDU 209 C	Role of the Paraprofessional	3
EDU 211 C	Diverse Learners Practicum	3
Total Units Required		18

Education (EDU)

EDU 200 C Elementary School Teaching**3 Units***Advisory: Completion of COUN 110 C or at least one year as a paraprofessional in a public school setting.*

Term hours: 40–45 lecture and 40–45 laboratory TBA. This course provides an overview of the teaching profession for students who are considering a career in elementary school teaching. The course will address the philosophies of education, the history of education in America, the sociology of education, contemporary issues in education, and the role of education in American society. In addition, students will gain experience through 45 hours of required fieldwork in K-6 elementary classrooms. Students will divide the 45 hours as follows: 20 hours in an ELL (English Language Learners) classroom, 15 additional hours will be spent at the primary school and the last 10 hours will be spent in a second elementary school. (CSU)

EDU 204 C Introduction to Special Education**3 Units**

Term hours: 48–54 lecture. This course provides an overview of special education. It includes the theoretical and educational foundations of special education, a historical background of the field of special education, legal issues, and techniques for inclusion of individuals with special needs in all settings. Various implications of full inclusion are discussed, including the role and responsibilities of key members of the educational team, including educational sign language interpreters. (CSU)

EDU 208 C Children With Disabilities**3 Units**

Term hours: 48–54 lecture. This course is designed for teachers, administrators, parents and others in supporting children with special needs and their families. The first part of the course will focus on supporting families of children with special needs in early childhood settings. Developing techniques and strategies to provide this support will be emphasized, as well as building a knowledge base of resources available to parents and early childhood programs. There will be a focus on creating inclusive environments for young children and their families. (CSU)

EDU 209 C Role of the Paraprofessional**3 Units**

Term hours: 48–54 lecture. This course is an overview of the roles and responsibilities of paraprofessional including legal, instruction, evaluation and behavioral components. It is designed to train persons to work as classroom teaching assistants in public schools. This course meets the current legislative requirements for paraprofessionals. (CSU)

EDU 211 C Diverse Learners Practicum 3 Units

Term hours: 48–54 lecture. This course is designed for those who are or will be assisting in the elementary through secondary educational setting. Students will be prepared to facilitate classroom and community practices for diverse learners (individuals who have disabilities, are second language learners, are gifted, etc.) Topics will include literacy, language, and behavior support. Introductory knowledge in the assessment, design, and implementation of life-span curriculum and methodology will be covered. (CSU)

EDU 225 C Secondary School Teaching 3 Units

Advisory: COUN 110 C.

Term hours: 40–45 lecture and 40–45 laboratory TBA. History, philosophy, and sociology of secondary education. Introduction to the California Teaching Performance Expectations and Assessment; needs of special populations, English learners, and struggling readers; content standards; and major curriculum reform documents. In addition, students will gain experience through 45 hours of required fieldwork in secondary classrooms. Students will divide the 45 hours as follows: 30 hours at one site and 15 hours in various other sites/activities for diversity. (CSU)

Electricity

Division of Career Technical Education

Division Dean — Steve Donley

Counselor
Jane Jepson

Electricity (ELEC)

ELEC 051 C Basic Electricity 2 Units

Term hours: 32–36 lecture and 32–36 laboratory. This course provides a non-mathematical treatment of AC and DC circuits including the following: current, voltage, resistance, power, magnetism, relays, motors, generators, automotive electrical system, rectifying circuits, and the use of the oscilloscope and related test equipment. This course is not open to those who have completed a previous college course in electricity or electronics and cannot be counted toward the electronic engineering technology major. Pass/No Pass/Letter Grade Option. (CSU)

Electronics — See Engineering Technology (ENGT)

Engineering

Division of Science/Engineering/Mathematics

Division Dean — Richard Fee

Faculty
Brinda Subramaniam

Counselor
Deidre Porter

ASSOCIATE IN SCIENCE DEGREE

PRE-ENGINEERING Program Code: 1S03770

This Pre-Engineering program is designed to prepare students for junior standing at most CSU and UC institutions.

To earn an Associate Degree students must complete: (1) all major course requirements with a minimum grade of “C”; (2) 25 units of General Education Graduation Requirements; (3) the cultural diversity and reading requirements; (4) any elective courses to complete a minimum of 60 units; and, (5) have a minimum GPA of 2.0. At least 50% of all major course work must be completed at Cypress College.

Courses that fulfill major requirements for an Associate Degree at Cypress College might not be the same as those required for completing the major at a transfer institution offering a Baccalaureate Degree. For information on specific university requirements, please consult with your counselor, or visit the Transfer Center.

Required courses are listed in suggested sequence:

Course #	Title	Units
*MATH 150AC	Calculus and Analytic Geometry	4
**MATH 150BC	Calculus and Analytic Geometry	4
MATH 250AC	Multivariable Calculus	4
MATH 250BC	Linear Algebra/Differential Equations	4
PHYS 221 C	General Physics	4
PHYS 222 C	General Physics	4
PHYS 223 C	General Physics	4
CHEM 111AC	General Chemistry	5
CHEM 112 C	Chemistry for Engineers	3
ENGT 101 C	Technical Drawing	3
ENGT 104 C	Computer Aided Design	3
ENGR 102 C	Engineering Graphics	3
ENGR 110 C	Introduction to Engineering	2
ENGR 201 C	Statics	3
ENGR 210 C	Electric Circuits	4
CSCI 185AC	Computer Science I	4
	or	
CSCI 205 C	FORTTRAN Programming	(3)
	Total Units Required	58

*A score of 3 or higher on the Advanced Placement (AP) Math (Calculus AB) exam meets this requirement upon petition through Admissions and Records. See a counselor for more information.

**A score of 3 or higher on the Advanced Placement (AP) Math (Calculus BC) exam meets this requirement upon petition through Admissions and Records. See a counselor for more information.

Flow Chart for Physics/Engineering Courses

Courses

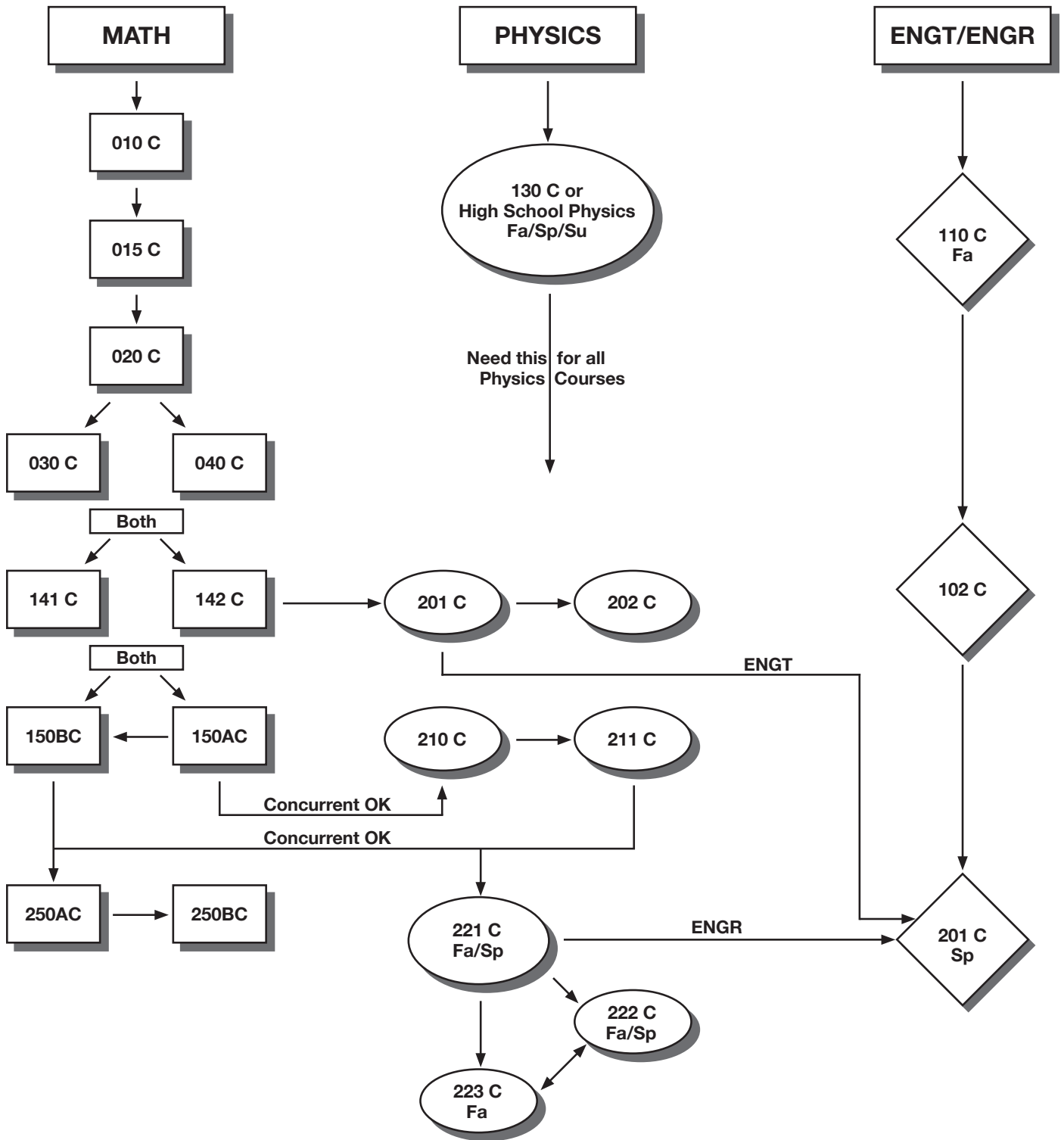

Fa = Fall Sp = Spring Su = Summer

Contact: Dr. Brinda Subramaniam: bsubramaniam@CypressCollege.edu or (714) 484-7000 x48645

ENGINEERING TRANSFER PROGRAM

Students should consult a counselor or www.assist.org for lower division major requirements for most California public universities. (See the Standard Definitions section of the catalog for a description of ASSIST.) Students transferring to an independent college/university should consult the catalog of the individual school and a counselor for lower division major requirements.

Engineering (ENGR)

ENGR 102 C Engineering Graphics 3 Units

Term hours: 32–36 lecture and 64–72 laboratory. This is an introductory course which utilizes drafting and the CAD system for engineering applications. The course incorporates elementary principles associated with the board drawing and the various menu and command structures in computer-assisted drafting (CAD) in order to develop solutions to 2D and 3D design problems. Topics included are drawing of points, lines, planes, plane intersections, orthographic projection, dimensioning, line types, tolerances, file management, and layering. (UC/CSU)

ENGR 110 C Introduction to Engineering 2 Units

Same as ENGT 110 C.

Prerequisite: MATH 040 C.

Term hours: 48–54 lecture. This course is an introduction to engineering as a profession and its associated career responsibilities and opportunities. The course includes a selection of computational and mathematical methods and tools to be found useful in problem solving. Dimensional analysis, graphical techniques, and design theory in engineering analysis is also studied. The course includes the application of engineering and scientific problem methods to introductory mechanics and electricity. This course also meets requirements for credit in Engineering major. Pass/No Pass/Letter Grade Option. (UC/CSU)

ENGR 201 C Statics 3 Units

Prerequisite: ENGR 110 C, PHYS 201 C or PHYS 221 C, MATH 142 C or MATH 150AC.

Term hours: 48–54 lecture. This course includes the study of force systems, equilibrium conditions, and analytical vector mechanics as applied to practical engineering problems. It also includes force and moment equilibrium analysis of solid bodies, beams, machine members, and structures in two and three dimensions, elementary bending moment and shear analysis of simple beams, distributed beam loading, centroids, friction forces, fluid forces on submerged surfaces, virtual work, and moment of inertia. (UC/CSU)

ENGR 205 C Advanced Engineering Autocad 3 Units

Prerequisite: ENGT 104 C and ENGR 102 C.

Term hours: 32–36 lecture and 64–72 laboratory. This is an advanced course in the use of Computer Aided Design (CAD) systems for projects that emphasize dimensioning and detailing for interchangeable assemblies and 3D working drawings for mechanical, electrical, and aerospace applications. May be taken for credit 2 times. \$4.00 Material Fee — Payable at Registration. (CSU)

ENGR 210 C Electric Circuits 4 Units

Prerequisite: PHYS 222 C, MATH 250AC, and ENGR 110 C.

Term hours: 48–54 lecture and 48–54 laboratory. The course consists of an analysis of circuits under steady state and transient conditions; network theorems, phasors and steady-state sinusoids. (UC/CSU)

ENGR 299 C Engineering Independent Study .5 to 2 Units

Prerequisite: Approved Independent Study Contract.

Term hours: 0–36 lecture and/or 0–108 laboratory depending on units attempted. Students who wish to increase their knowledge of engineering design and testing process through individual study, research or internships may enroll in this class. Permission of the instructor is required along with a contract outlining a student's independent work and the supervision of the instructor. May be taken for credit 4 times. Pass/No Pass/Letter Grade Option. (UC/CSU Credit Limitation)

Engineering Technology

Division of Science/Engineering/Mathematics

Division Dean — Richard Fee

Faculty

Brinda Subramaniam

Counselor

Deidre Porter

ASSOCIATE IN SCIENCE DEGREE

DRAFTING ENGINEERING TECHNOLOGY

Program Code: 1S07831

The primary emphasis is to prepare the student for employment. Students must complete 40 units from the core section and 25 units from General Education.

To earn an Associate Degree students must complete: (1) all major course requirements with a minimum grade of "C"; (2) 25 units of General Education Graduation Requirements; (3) the cultural diversity and reading requirement; (4) any elective courses to complete a minimum of 60 units; and, (5) have a minimum GPA of 2.0. At least 50% of all major course work must be completed at Cypress College.

Courses that fulfill major requirements for an Associate Degree at Cypress College might not be the same as those required for completing the major at a transfer institution offering a Baccalaureate Degree. For information on specific university requirements, please consult with your counselor, or visit the Transfer Center.

Required courses are listed in suggested sequence:

Course #	Title	Units
MATH 130 C	Survey of Calculus	4
MATH 141 C	College Algebra	4
MATH 142 C	Trigonometry	4
PHYS 201 C	College Physics	4
PHYS 202 C	College Physics	4
ENGT 101 C	Technical Drawing	3
ENGT 104 C	Computer Aided Design	3
ENGT 205 C	Advanced Engineering AutoCAD	3
ENGR 102 C	Engineering Graphics	3
ENGR 110 C	Introduction to Engineering	2
ENGR 201 C	Statics	3

ENGINEERING TECHNOLOGY TRANSFER PROGRAM

Students should consult a counselor or www.assist.org for lower division major requirements for most California public universities. (See the Standard Definitions section of the catalog for a description of ASSIST.) Students transferring to an independent college/university should consult the catalog of the individual school and a counselor for lower division major requirements.

Other specializations include: Construction, Manufacturing, and Quality Assurance.

Engineering Technology (ENGT)**ENGT 101 C Technical Drawing 3 Units**

Prerequisite: MATH 010 C, or equivalent high school mathematics, with a grade of "C" or better.

Term hours: 32–36 lecture and 64–72 laboratory. Principles of graphical drawing for students who have no background in this subject area are studied. This course covers the proper use of drawing instruments, lettering, sketching, multiview (orthographic projections), geometric constructions, isometrics and pictorials, sections, auxiliary views, base line dimensioning with tolerances, weight calculations, notes and bill materials composition. (CSU)

ENGT 104 C Computer Aided Design 3 Units

Prerequisite: ENGT 101 C, or employed in the field.

Term hours: 32–36 lecture and 64–72 laboratory. This is an introduction to Computer Aided Design using AutoCAD systems and techniques with emphasis on using a menu driven software package for creating drawing data files of schematics, multiview (orthographic projections), sections, isometrics, baseline dimensioning with tolerances, notes, and bill of materials. The course is designed to prepare the student for industry, technology, or engineering uses of the AutoCAD system. \$4.00 Material Fee — Payable at Registration. (CSU)

ENGT 110 C Introduction to Engineering 2 Units

Same as ENGR 110 C.

Prerequisite: MATH 040 C.

Term hours: 48–54 lecture. This course is an introduction to engineering as a professions and its associated career responsibilities and opportunities. The course includes a selection of computational and mathematical methods and tools to be found useful in problem solving. Dimensional analysis, graphical techniques, and design theory in engineering analysis is also studied. The course includes the application of engineering and scientific problem methods to introductory mechanics and electricity. This course also meets requirements for credit in Engineering major. Pass/No Pass/Letter Grade Option. (UC/CSU)

ENGT 140 C AC and DC Circuits I 4 Units

Prerequisite: MATH 040 C may be taken concurrently.

Term hours: 48–54 lecture and 48–54 laboratory. This is an introductory course in AC and DC circuits, with emphasis on the measurement of electrical quantities using equipment such as the voltmeter, ammeter, ohmmeter, capacitor-checker, oscilloscope, impedance bridge, potentiometer, and wattmeter. Also introduced are some basic electronic circuits using solid-state devices and the use of the transistor tester. This course is designed for those wishing to continue beyond ELEC 051 C or as the first course in an electronic engineering technology program. It is also a required course for all engineering technology students. Credit by Examination. Pass/No Pass/Letter Grade Option. (CSU)

ENGT 205 C Advanced Engineering AutoCAD 3 Units

Prerequisite: ENGT 104 C and ENGR 102 C.

Term hours: 32–36 lecture and 64–72 laboratory. This is an advanced course of Computer Aided Design CAD (AutoCAD 2000) systems that emphasize the use of surfaces, surfaces of revolution, solids (primitives) and extrusions techniques to create 3D working drawings. To convert 3D drawings by layout methods to 2D drawings that emphasize baseline dimensioning with tolerances, notes, weights and bill of materials. To write unique graphical programs by using LISP. May be taken for credit 2 times. \$4.00 Material Fee — Payable at Registration. (CSU)

ENGT 299 C Engr Technology Ind Study .5 to 2 Units

Prerequisite: Approved Independent Study Learning Contract.

Term hours: Hours and topics by arrangement with instructor. This course is for able students who wish to extend their knowledge of a particular area of engineering technology (electronics, mechanics, etc.) through individual research, study and laboratory work. Students may select their own topics or be assigned a project to work on under supervision. May be taken for credit 4 times. (CSU)

English**Division of Language Arts**

Division Dean — Eldon Young

Faculty

Linda Borla
Joan Daniels
Nancy Deutsch
Cherie Dickey
Christie Diep
Mary Forman
Cathy Franklin
Janet Fujimoto
Sarah Jones
Barbara Kashi
Lawrence Keel
Margaret Klein
Barbara Marshall
Kathleen McAlister
Joseph Melodia
Melanie Nabahani
John Payne
Stuart Rosenberg
Kathryn Sonne
Ambika Talwar
Keith Vescial
Randa Wahbe

Counselors

Velia Lawson
Therese Mosqueda-Ponce
Daniel Pelletier

PROGRAM LEARNING OUTCOMES (PLOs)

The courses taught by this department contribute to the General Education and Basic Skills Program Learning Outcomes. Please refer to General Education and Basic Skills Program Learning Outcomes.

Flow Chart for Pre-English 100 C Courses

Students are advised to take English classes according to scores on the following test:

COLLEGE TEST FOR ENGLISH PLACEMENT (CTEP)

The CTEP is designed to measure the English skills of native speakers of English. It is required for proper placement in English courses. Exemptions are: completion of an AA degree or higher, enrollment in one class that has no prerequisite; transcripts/grade reports showing completion of college English with a grade of “C” or better. The CTEP may not be used for placement in ESL courses.

Students with appropriate scores on the CTEP will be advised to take ENGL 100 C (College Writing). Students needing additional fundamental work will be advised to take either ENGL 057 C (Reading and Writing I), ENGL 058 C (Reading and Writing II), or ENGL 060 C (Preparation for College Writing). Students enrolled in pre-English 100 C classes must earn at least a “C” grade in ENGL 060 C or a grade of “C” in ESL 186 C to be eligible for enrollment in ENGL 100 C. All students are encouraged to complete their English coursework as early as possible in their educational programs.

Students enrolled in core classes will be required to write an essay on the first day of instruction to verify skill level and assessment placement score.

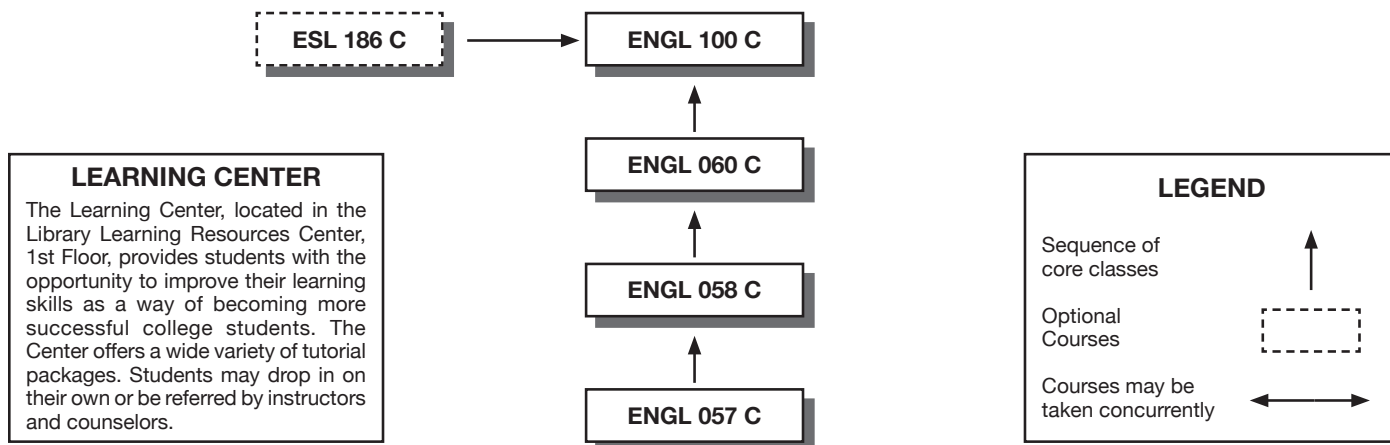

ENGLISH TRANSFER PROGRAM

Students should consult a counselor or www.assist.org for lower division major requirements for most California public universities. (See the Standard Definitions section of the catalog for a description of ASSIST.) Students transferring to an independent college/university should consult the catalog of the individual school and a counselor for lower division major requirements.

English (ENGL)

ENGL 027 C Basic Study Skills 3 Units

Term hours: 48–54 lecture. The purpose of this course is to assist students with limited academic backgrounds in experiencing college success by taking responsibility for their college experience. Intensive practice and guidance in campus orientation, goal setting, time management, listening and note taking, textbook reading, concentration, memory strategies, and test taking are provided. Non-Degree Credit. Pass/No Pass/Letter Grade Option.

ENGL 057 C Reading and Writing I 4 Units

Prerequisite: Student must have appropriate score on CTEP Assessment.
Term hours: 64–72 lecture hours. This course is designed for first semester college students and emphasizes basic instruction in reading and writing, including such topics as comprehension, vocabulary development, reading efficiency, study techniques, and basic composition. Individualized instruction is provided. Non-Degree Credit. Pass/No Pass/Letter Grade Option.

ENGL 058 C Reading and Writing II 4 Units

Prerequisite: Completion of ENGL 057 C with a “C” or better, or acceptable score on the placement test.

Term hours: 64–72 lecture. This course is designed to prepare students for ENGL 060 C and for the demands of college reading and writing. It emphasizes a comprehensive approach to reading and writing and includes such topics as: academic comprehension, vocabulary development, and basic academic composition. Individualized instruction is included. Non-Degree Credit. Pass/No Pass/Letter Grade Option.

ENGL 060 C College Writing Preparation 3 Units

Prerequisite: Acceptable score on placement test, ENGL 058 C with a grade of “C” or better, or ESL 186 C with a grade of “C” or better.

Term hours: 64–72 lecture. The focus of this course is reading, critical analysis, and writing expository essays. The course reviews the fundamentals of grammar, sentence structure, and paragraph development. Non-Degree Credit. Pass/No Pass/Letter Grade Option.

ENGL 096 C College Reading Strategies 3 Units

Prerequisite: Eligibility for ENGL 060 C or acceptable score on the placement test.

Term hours: 48–54. This course is designed to prepare students for the demands of college academic reading, i.e., college textbooks, professional journals, and supplemental reading in content areas, and for the demands of technical reading in the workplace. Emphasis is placed on acquiring, applying, adapting, and evaluating effective reading and writing strategies which facilitate optimum learning in the content area classes, as well as developing general and specialized vocabulary and the writing skills required for essay exams, abstracts of professional journal articles, and critical analyses of content area supplemental reading. Completion of this course satisfies the Cypress College Associate Degree Graduation Reading Proficiency Requirement. Pass/No Pass/Letter Grade Option.

ENGL 097 C Multicultural Literature 3 Units

Term hours: 48–54 lecture. The course is a study of multicultural literature, by both immigrant and native American writers, which explores varied responses — ethnic, gender, and regional — in the cultural context of a diverse country. Students critically analyze a variety of literary sources, including such genres as fiction, drama, expository writing — essays, journals, autobiography, letters — and other less traditional literary forms — tales, chants, and rituals. The course is designed to enrich students' lives by exploring the multicultural literary sources of America that contribute to the cultural history and development of contemporary American society. Not open to students with credit in ENGL 247 C. (AA GE, CUL DIV)

ENGL 098 C Language Arts Seminar .5 to 12 Units

Prerequisite: May be required.

Corequisite: May be required.

Advisory: May be required.

Term hours: 0–216 lecture and/or 0–432 laboratory depending on units attempted. This seminar is for students who wish to extend their knowledge of English, reading, and study skills through small group discussion. May be taken for credit 1–4 times. Pass/No Pass or Pass/No Pass/Letter Grade Option or Standard Letter Grade. Fees may be required — Payable at Registration.

ENGL 100 C College Writing 3 Units

Prerequisite: Acceptable score on placement test or ENGL 060 C with a grade of "C" or better, ENGL 095 C with a grade of "C" or better or ESL 186 C with a grade of "C" or better.

Term hours: 64–72 lecture. This course is a college level course in written communication. It is designed to develop reading, critical thinking, and writing strategies necessary for academic success. The emphasis is on writing expository essays. The course requires the use of research and documentation skills. Duplicate credit not granted for ENGL 100HC. (UC Credit Limitation/CSU, AA GE, CSU GE, IGETC)

ENGL 100HC Honors College Writing 3 Units

Prerequisite: Acceptable score on placement test or ENGL 060 C with a grade of "C" or better or ENGL 095 C with a grade of "C" or better, or ESL 186 C with a grade of "C."

Term hours: 64–72 lecture. This course is a college level course enhanced for Honors students. The emphasis is on reading and writing expository essays. The course will develop increased critical thinking, reading and writing skills. The class will be conducted as a seminar and will require a significant research project that uses correct documentation skills. Duplicate credit not granted for ENGL 100 C. (UC Credit Limitation/CSU, AA GE, CSU GE, IGETC)

ENGL 102 C Introduction to Literature 3 Units

Prerequisite: ENGL 100 C with a grade of "C" or better.

Term hours: 48–54 lecture. This course is a continuation of ENGL 100 C. It builds from the inferential reading and expository writing of the first semester course to demonstrate reading comprehension as well as composition of the analytical and critical essay. The content introduces students to techniques and major authors of narrative fiction, drama, and poetry, providing them with an opportunity to enrich their lives, enhance their understanding of the human condition, and develop an appreciation of good literature. (UC/CSU, AA GE, CSU GE, IGETC, RDG)

ENGL 102HC Honors Introduction to Literature 3 Units

Prerequisite: ENGL 100 C or ENGL 100HC.

Term hours: 48–54 lecture. This course is enhanced for honors students. The course is a continuation of ENGL 100 C or ENGL 100HC. It builds from the inferential reading and expository writing of the first semester course to demonstrate reading comprehension as well as composition of the analytical and critical essay. The content introduces students to techniques and major authors of narrative fiction, drama, and poetry, providing them with an opportunity to enrich their lives, enhance their understanding of the human condition, and develop an appreciation of literature. The class is conducted as a seminar and will require additional writing and documented research assignments. Duplicate credit not granted for ENGL 102. (UC Credit Limitation/CSU, AA GE, CSU GE, IGETC, RDG)

ENGL 103 C Critical Reasoning and Writing 3 Units

Prerequisite: ENGL 100 C with a grade of "C" or better.

Term hours: 48–54 lecture. This course is designed to develop critical thinking, reading and writing skills beyond the level achieved in ENGL 100 C. The course will focus on the development of logical reasoning and analytical and argumentative writing skills. (UC/CSU, AA GE, CSU GE, IGETC)

ENGL 104 C Critical Analysis and Literature 4 Units

Prerequisite: ENGL 100 C or ENGL 100HC with a grade of "C" or better.

Term hours: 48–54 lecture. This course will develop critical thinking, reading and writing skills as they apply to the analysis of literature and literary criticisms from diverse cultural sources and perspectives. There will be an emphasis on the techniques and principles of effective written argument as they apply to literature. Students will demonstrate this understanding by writing and critiquing essays and utilizing research strategies. Duplicate credit not granted for ENGL 104HC. (UC Credit Limitation/CSU, AA GE, CSU GE, IGETC)

ENGL 104HC Honors Critical Analysis and Literature 4 Units

Prerequisite: ENGL 100 C with a grade of "C" or better.

Term hours: 64–72 lecture. This course is a college level course enhanced for honors students. The emphasis is on developing increased critical thinking, reading and writing skills as they apply to the analysis of literature and literary criticism. Writing expanded argumentative research essays, and utilizing enhanced research strategies and documentation skills will be required. The class will be conducted as a seminar. Duplicate credit not granted for ENGL 104 C. (UC Credit Limitation/CSU, AA GE, CSU GE, IGETC)

ENGL 105 C Creative Writing 3 Units

Prerequisite: ENGL 100 C.

Term hours: 48–54 lecture. This class provides an opportunity for students to write short fiction, poetry, and, optionally, a short play. Students will gain an understanding of each literary type, create material in each area, and have their work critiqued in a workshop setting. May be taken for credit 2 times. (UC/CSU)

ENGL 106 C Critical Thinking 3 Units

Prerequisite: ENGL 100 C or ENGL 100HC with minimum grades of "C."

Term hours: 48–54 lecture. This course develops critical reading, writing and thinking skills. Emphasis is placed on learning the strategies necessary to analyze and evaluate rhetorical and logical elements of written communication. Completion of this course satisfies the Cypress College Associate Degree Graduation Reading Proficiency Requirement. (UC/CSU, AA GE, CSU GE, RDG)

ENGL 108 C Writing the Personal Statement .5 Units

Prerequisite: ENGL 100 C.

Term hours: 8–9 lecture. This course will teach students how to write an effective personal statement on their transfer applications to four-year institutions. Content strategies and essay format will be discussed and opportunities for multiple drafts will be engaged. Pass/No Pass only. (CSU)

ENGL 110 C Humanities: Ancient and Medieval 3 Units

Same as INDS 100 C.

Prerequisite: Eligibility for ENGL 100 C.

Term hours: 48–54 lecture. This course is a survey of the development of Western culture with a focus upon its Greco-Roman roots, and a study of other important influences, including African and Middle Eastern. The course covers prehistory to the Renaissance, with an emphasis on the arts. Duplicate credit not granted for INDS 100 C. Cost for museum visits not to exceed \$15.00. (UC/CSU, AA GE, CSU GE, IGETC)

ENGL 111 C Humanities: Renaissance–Present 3 Units

Same as INDS 101 C.

Prerequisite: Eligibility for ENGL 100 C.

Term hours: 48–54 lecture. This course is a survey of the development of Western culture from the Renaissance to the present, including a study of other important influences from Africa, the Middle East, and North and South America, with emphasis on the arts. Duplicate credit not granted for INDS 101 C. Cost for museum visits not to exceed \$15.00. (UC/CSU, AA GE, CSU GE, IGETC)

ENGL 125 C The Film 3 Units

Prerequisite: ENGL 100 C.

Term hours: 48–54 lecture. This course is a critical study of film as literature that will develop critical thinking and writing skills. Students will study the elements of film making and the historical development of film. Film as a story telling art form will be emphasized. Ten to twelve films will be shown in class for analysis and discussion. Students will be expected to watch and study several additional films outside of class. Duplicate credit not granted for ENGL 125HC. (UC Credit Limitation/CSU, AA GE, CSU GE, IGETC)

ENGL 125HC Honors Film 3 Units

Prerequisite: ENGL 100 C or ENGL 100HC.

Term hours: 48–54 lecture. This course is a critical study of film as a story telling art form enhanced for Honors students. Students study the elements of cinematic storytelling, film's dependence on literature, and the historical development of film. Ten to twelve short and feature films are shown in the course for discussion and analysis. Students will be expected to watch and study several additional films outside of class. The course is taught in a seminar format. Duplicate credit not granted for ENGL 125 C. (UC Credit Limitation/CSU, AA GE, CSU GE, IGETC)

ENGL 126 C Screenwriting 3 Units

Prerequisite: ENGL 100 C.

Term hours: 48–54 lecture. This course provides students the opportunity to study the art of the screenplay and create their own. Students will critically analyze professional models, view excellent examples of film writing, and work on their own screenplay. Students will have the opportunity to have their work critiqued in a workshop setting. May be taken for credit 2 times. May be taken for credit 2 times. (UC/CSU, AA GE)

ENGL 135 C Advanced Grammar and Usage 3 Units

Prerequisite: Eligibility for ENGL 100 C.

Term hours: 48–54 lecture. This is an advanced course in English grammar and usage. Students will learn about the origins and development of the English language. Parts of speech, parts of sentences, verb tenses, sentence types, syntax, and standard usage will be emphasized. Students will demonstrate their understanding of English grammar and usage by analyzing standard written English. This course is useful for English, journalism, foreign language, and court reporting students and especially for those planning to enter elementary or secondary teaching. (CSU, AA GE)

ENGL 137 C College Study Strategies 3 Units

Prerequisite: Eligibility for ENGL 060 C.

Term hours: 48–54 lecture. The purpose of this course is to assist students in mastering effective learning and critical thinking strategies crucial for academic success and professional and personal growth. Goal setting and motivation, learning styles, time management, stress management, academic and professional reading, reading rate improvement, listening for note-taking, concentration, memory, test preparation, and test-taking strategies are primary topics. Pass/No Pass/Letter Grade Option. (CSU)

ENGL 180 C Sign Language — SEE Level I 3 Units

Term hours: 48–54 lecture. This course gives an overview of the Signing Exact English (SEE) model of sign language. Students will explore the philosophy and rationale of the sign system while developing both expressive and receptive delivery skills. It is designed to introduce students to a 700-word working vocabulary and to prepare them to continue on to ENGL 181 C. (CSU)

ENGL 181 C Sign Language — SEE Level II 3 Units

Prerequisite: ENGL 180 C.

Term hours: 48–54 lecture. Students will acquire approximately 1,000 additional signs and will improve expressive and receptive fluency with both signs and fingerspelling. Students will continue to address the rationale and philosophy of using the English sign model: Signing Exact English. (CSU)

ENGL 182 C Sign Language — SEE Level III 3 Units

Prerequisite: ENGL 181 C.

Term hours: 48–54 lecture. Students will increase the size of their sign lexicon, increase delivery speed, and refine fingerspelling skills. Students will also create a personal video portfolio monitoring their progress. Students will also explore issues and complete activities designed to develop a greater understanding of deafness and its impact on building English skills through presentation of a consistent model. (CSU)

ENGL 183 C Educational Interpreting I 3 Units

Prerequisite: ENGL 182 C with a minimum grade of "C" or three semesters of college level sign language classes in either American Sign Language, Pidgin Sign Language, Signed English, or Signing Exact English with minimum grades of "C."

Term hours: 48–54 lecture. This course prepares students to offer sign language interpreting services for the Deaf and Hard of Hearing (DHH) with specific focus on service provision in the elementary and middle school level educational settings. Students will explore the rationale and methods of the service delivery models specifically targeting educational interpreting, address the ethics of educational interpreting, and learn about the certification process for educational interpreters in the state of California. (CSU)

ENGL 184 C Educational Interpreting Practicum I 3 Units

Prerequisite: ENGL 182 C with a minimum grade of "C" or three semesters of college level sign language classes in either American Sign Language, Pidgin Sign Language, Signed English, or signing Exact English with minimum grades of "C."

Term hours: 48–54 lecture. This course will provide opportunities enabling students to apply previously learned theory to sign language interpreting services for the Deaf and Hard of Hearing (DHH). There is a specific focus on service provision in the elementary and middle school level educational settings. Students will apply learned rationale and methods to a service delivery model specifically targeting educational interpreting, demonstrate application of the ethics of educational interpreting, and work toward certification for educational interpreters in the state of California. May be taken for credit 4 times. (CSU)

ENGL 185 C Educational Interpreting II 3 Units

Prerequisite: ENGL 183 C with a minimum grade of “C” or a minimum grade of “C” in three semesters of college level sign language courses in either American Sign Language, Pidgin Sign Language, Signed English, or Signing Exact English.

Term hours: 48–54 lecture. This course prepares students to offer sign language interpreting services for the Deaf and Hard of Hearing (DHH) with specific focus on service provision in the high school, vocational, and higher educational settings. Students will explore the rationale and methods of the service delivery models specifically targeting educational interpreting, continue to address the ethics of educational interpreting, and learn about the certification process for educational interpreters in the state of California. (CSU)

ENGL 186 C Educational Interpreting Practicum II 3 Units

Prerequisite: ENGL 184 C with a minimum grade of “C” or a minimum grade of “C” in three semesters of college level sign language classes in either American Sign Language, Pidgin Sign Language, Signed English, or Signing Exact English.

Term hours: 48–54 lecture. This course will provide students with opportunities to apply previously learned theory to sign language interpreting services for the Deaf and Hard of Hearing (DHH). There is a specific focus on service provision in the high school, vocational, and higher educational settings. Students will apply learned rationale and methods to a service delivery model specifically targeting educational interpreting, demonstrate application of the ethics of educational interpreting, and work toward certification for educational interpreters in the state of California. (CSU)

ENGL 208 C Asian-American Literature 3 Units

Prerequisite: ENGL 100 C.

Term hours: 48–54 lecture. This course is a study of Asian-American literature. Students will explore and analyze a variety of social and political issues, such as gender relationships, family relationships, cultural traditions, cultural conflicts, culinary traditions, and stereotypes from an Asian-American perspective. This course is designed to enhance cultural awareness and understanding, while also facilitating personal enrichment through the exploration of a variety of literary sources, including fiction, drama, poetry, journals, biography and film. (UC/CSU, AA GE, CSU GE, IGETC)

ENGL 211 C English Literature to 1760 3 Units

Prerequisite: ENGL 100 C.

Advisory: ENGL 102 C.

Term hours: 48–54 lecture. The course is an introduction to the major periods and movements, major authors, and major forms from the beginning of English literature to 1760. It covers works such as Beowulf, and Sir Gawain and the Green Knight, as well as works from authors such as Marie de France, Chaucer, Marlowe, Shakespeare, Donne, Milton, Pope, and Swift. (UC/CSU, AA GE, CSU GE, IGETC)

ENGL 212 C English Literature Since 1760 3 Units

Prerequisite: ENGL 100 C or ENGL 100HC.

Advisory: ENGL 102 C.

Term hours: 48–54 lecture. The course is an introduction to the major periods and movements, major authors, and major forms from 1760 to the present. It considers literary trends and historical backgrounds from the Romantic, Victorian, Modern, and Postmodern eras. It covers fiction, poetry, drama, and prose from such authors as Wollstonecraft, Blake, Wordsworth, Coleridge, Byron, Shelley, Keats, Browning, Dickens, Wilde, Joyce, Hopkins, Yeats, Eliot, Woolf, and Beckett. (UC/CSU, AA GE, CSU GE, IGETC)

ENGL 221 C American Literature to 1865 3 Units

Prerequisite: ENGL 100 C or ENGL 100HC.

Advisory: ENGL 102 C.

Term hours: 48–54 lecture. This course is a survey of the literature of American writers from the Colonial Period to 1865. It is designed to increase understanding and appreciation of the development of American culture and literary achievements. A diversity of writings will be included to reflect the various subjects and styles that comprise the development of American Literature. (UC/CSU, AA GE, CSU GE, IGETC)

ENGL 222 C American Literature Since 1865 3 Units

Prerequisite: ENGL 100 C or ENGL 100HC.

Advisory: ENGL 102 C.

Term hours: 48–54 lecture. This course is a survey of the literature of American writers from 1865 to the present. It is designed to increase understanding and appreciation of the development of American culture and literary achievements. A diversity of writings will be included to reflect the various subjects and styles that comprise the development of American Literature. (UC/CSU, AA GE, CSU GE, IGETC)

ENGL 230 C Thematic Topics in Literature 3 Units

Prerequisite: ENGL 100 C or ENGL 100HC.

Term hours: 48–54 lecture. This course is designed to provide students with experiences in specialized areas of English and an opportunity to explore and investigate areas of special interest. Courses such as Gender Issues in Literature, Humor in Literature, and Latino Literature are offered. Duplicate credit not granted for ENGL 230HC. (UC Credit Limitation/CSU)

ENGL 230HC Honors Thematic Topics 3 Units

Prerequisite: ENGL 100 C or ENGL 100HC.

Term hours: 48–54 lecture. This is a college level course enhanced for Honors students. The course is designed to provide students with enhanced experiences in specialized areas of English and an opportunity to explore and investigate areas of special interest. Courses such as Gender Issues in Literature, Humor in Literature, and Latino Literature are offered. The class will be conducted as a seminar and will require a significant research project using advanced research skills and documentation. Duplicate credit not granted for ENGL 230 C. (UC Credit Limitation/CSU)

ENGL 231 C Fiction Topics in Literature 3 Units

Prerequisite: ENGL 100 C or ENGL 100HC.

Term hours: 48–54 lecture. This course is designed to provide students with experiences in specialized areas of English and an opportunity to explore and investigate areas of special interest. Courses such as The British Novel and The American Novel are offered. Duplicate credit not granted for ENGL 231HC. (UC Credit Limitation/CSU)

ENGL 231HC Honors Fiction Topics 3 Units

Prerequisite: ENGL 100 C or ENGL 100HC.

Term hours: 48–54 lecture. This is a college level course enhanced for Honors students. The course is designed to provide students with enhanced experiences in specialized areas of English and an opportunity to explore and investigate areas of special interest. Courses such as The British Novel and The American Novel are offered. The class will be conducted as a seminar and will require a significant research project using advanced research skills and documentation. Duplicate credit not granted for ENGL 231 C. (UC Credit Limitation/CSU)

ENGL 234 C Shakespeare 3 Units*Prerequisite: ENGL 100 C or ENGL 100HC.*

Term hours: 48–54 lecture. The course is an introduction to the major works of William Shakespeare. The emphasis is upon the plays and includes a study of selected comedies, histories, and the major tragedies. Ten to twelve plays will be studied along with a selection of the sonnets. Duplicate credit not granted for ENGL 234HC. (UC Credit Limitation/CSU, AA GE, CSU GE, IGETC)

ENGL 234HC Honors Shakespeare 3 Units*Prerequisite: ENGL 100 C or ENGL 100HC.*

Term hours: 48–54 lecture. This is a college level course enhanced for Honors students. The emphasis is on developing increased critical thinking, reading, and writing skills as they apply to an analysis of William Shakespeare's sonnets and his major plays, both as texts and in performance. The class will be conducted as a seminar. Duplicate credit not granted for ENGL 234 C. (UC Credit Limitation/CSU, AA GE, CSU GE, IGETC)

ENGL 239 C Survey — Children's Literature 3 Units*Prerequisite: Completion of ENGL 100 C or ENGL 100HC with a grade of "C" or better.*

Term hours: 48–54 lecture. This course surveys the historical and cultural development of children's literature throughout the world, while emphasizing the important role that literature must assume in the social, emotional, and intellectual development of children. Tracing the multicultural origins of the oral tradition to the current standards of written excellence and pictorial artistry, this course concentrates on nursery rhymes, poetry, folk tales, myth, sacred literature, picture books, juvenile literature, and non-fiction. Comparative and critical approaches are used to analyze children's literature from a multicultural perspective. (UC/CSU, AA GE, CSU GE, CUL DIV)

ENGL 247 C Multicultural Literature 3 Units*Prerequisite: ENGL 100 C or ENGL 100HC.*

Term hours: 48–54 lecture. The course is a study of multicultural literature, by both immigrant and native American writers, which explores varied responses — ethnic, gender, and regional — in the cultural context of a diverse country. Students will critically analyze a variety of literary sources, including such genres as fiction, drama, expository writing — essays, journals, autobiography, letters, and other less traditional literary forms — tales, chants, and rituals. The course is designed to enrich students' lives by exploring the multicultural literary sources of America that contribute to the cultural history and development of contemporary American society. Not open to students with credit in ENGL 097 C. (UC/CSU, AA GE, CSU GE, IGETC, CUL DIV)

ENGL 255 C African-American Literature I 3 Units*Prerequisite: ENGL 100 C or ENGL 100HC with a grade of "C" or better.*

Term hours: 48–54 lecture. This course is an in-depth historical analysis of the African and African-American literary diaspora, which explores autobiography, letters, poems, narratives, prose and other folk traditions from the beginning of the slave era to the Reconstruction era in the United States. This course is designed to expose students to the literature and social issues of Africans in America. (UC/CSU, AA GE, CSU GE, IGETC, CUL DIV)

ENGL 256 C African-American Literature II 3 Units*Prerequisite: ENGL 100 C or ENGL 100HC with a grade of "C" or better.*

Term hours: 48–54 lecture. This course is an in-depth historical analysis of the African and African American literary diaspora, which explores autobiography, letters, poems, plays, prose and other folk traditions from the Civil War to present in the United States. This course is designed to expose students to the literature and social issues of Africans in America. (UC/CSU, AA GE, CSU GE, IGETC, CUL DIV)

ENGL 298 C Language Arts Seminar .5 to 12 Units

Term hours: 8–216 lecture depending on units attempted. This seminar is for able students who wish to extend their knowledge of literature, language and culture through small group discussion. Subject matter may concern the work of one author or the literary or cultural characteristics of a particular movement or period. May be taken for credit 1–4 times. Pass/No Pass or Pass/No Pass/Letter Grade Option or Standard Letter Grade. (UC Credit Limitation/CSU)

ENGL 299 C Language Arts Independent Study .5 to 2 Units*Prerequisite: Approved Independent Study Learning Contract.*

Term hours: 8–36 conference depending on units attempted. This course is for able students who wish to increase their knowledge of literature and/or language through individual study or research. Unit credit may range from .5 to 2 units in any given semester. May be taken for credit 3 times. (UC Credit Limitation/CSU)

English as a Second Language

Division of Language Arts

Division Dean — Eldon Young

Faculty

Hong Chi
Kathy Llanos
Debra McPherson
Alison Robertson
Kathryn Wada

Counselors

Velia Lawson
Therese Mosqueda-Ponce
Daniel Pelletier

PROGRAM LEARNING OUTCOMES (PLOs)

The courses taught by this department contribute to the General Education and Basic Skills Program Learning Outcomes. Please refer to General Education and Basic Skills Program Learning Outcomes.

English as a Second Language (ESL)

ESL 044 C Beginning Oral Skills 2 Units*Prerequisite: Appropriate skills demonstrated through the assessment process.*

Term hours: 32–36 lecture. This course is designed for high-beginning level non-native English speakers to improve basic oral communication skills related to social, vocational, and academic areas. The emphasis is on conversation, small group discussion, class discussion, and listening comprehension. Non-Degree Credit. May be taken for credit 2 times. Pass/No Pass/Letter Grade Option.

Flow Chart for ESL Courses

Courses

Is English your second language? Take the CELSA, the ESL placement test. The CELSA is the right test for you even if:

- you've been in the U.S. for a long time
- you don't have an accent
- you took "regular" English in high school

ESL courses are designed for your specific training needs.

Students are advised to take ESL classes according to scores on the COMBINED ENGLISH LANGUAGE SKILLS ASSESSMENT (CELSA) TEST FOR NON-NATIVE SPEAKERS OF ENGLISH.

The CELSA test is designed to measure the English skills of non-native speakers of English. The CELSA test is required for proper placement in

English as a Second Language (ESL) courses. The CTEP test, which is for native speakers of English, may not be substituted for placement in ESL courses.

However, students scoring high on the CELSA test may be referred to English courses for native speakers after writing a successful composition.

Students with appropriate scores on the CELSA test will be advised to take ESL core classes and elective classes at different levels.

Students enrolled in core classes will be required to write a composition on the first day of instruction to verify skill level and assessment placement score.

ADVANCED ELECTIVES

- ESL 066 C
Adv. Reading
- ESL 064 C
Adv. Oral Skills
- ESL 063 C
Adv. Grammar
- ESL 062 C
Adv. Grammar

INTERMEDIATE/BEGINNING ELECTIVES

- ESL 054 C
Int. Oral Skills
- ESL 053 C
Int. Grammar
- ESL 052 C
Int. Grammar
- ESL 051 C
Pronunciation
- ESL 044 C
Beg. Oral Skills

ESL CORE CLASSES

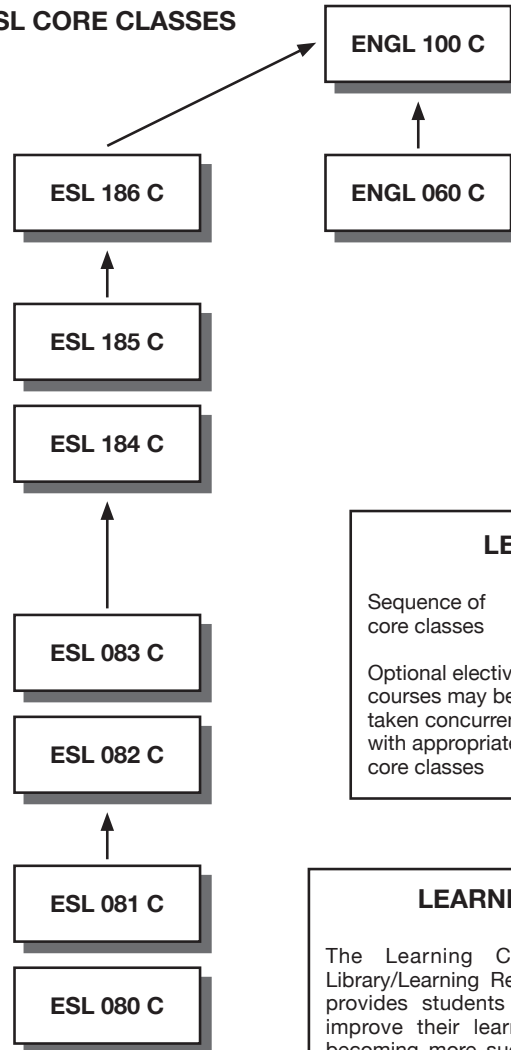

LEGEND

Sequence of core classes

Optional elective courses may be taken concurrently with appropriate core classes

LEARNING CENTER

The Learning Center, located in the Library/Learning Resource Center, 1st Floor, provides students with the opportunity to improve their learning skills as a way of becoming more successful college students. The Center offers a wide variety of tutorial packages. Students may drop in on their own or be referred by instructors and counselors.

ESL 051 C Intermediate Pronunciation 2 Units

Formerly ESL 074 C.

Prerequisite: Appropriate skills demonstrated through the assessment process.

Term hours: 32–36 lecture. This course is designed to refine pronunciation, to reduce foreign accent, and to build confidence in oral expression. Recommended to all ESL students. Non-Degree Credit. May be taken for credit 2 times. Pass/No Pass/Letter Grade Option.

ESL 052 C Intermediate ESL Grammar 1 3 Units*Prerequisite: Completion of ESL 081 C or appropriate skills demonstrated through the assessment process.*

Term hours: 48–54 lecture. This course is designed for intermediate ESL students to increase their knowledge and usage of English grammar, to review grammar trouble spots according to individual and class needs, and to improve grammatical accuracy and editing skills in writing. Non-Degree Credit. Pass/No Pass/Letter Grade Option.

ESL 053 C Intermediate ESL Grammar 2 3 Units*Prerequisite: Completion of ESL 081 C or appropriate skills demonstrated through the assessment process.*

Term hours: 48–54 lecture. This course is designed for intermediate ESL students to continue to increase their knowledge and usage of English grammar, to review grammar trouble spots according to individual and class needs, and to improve grammatical accuracy and editing skills in writing. Non-Degree Credit. Pass/No Pass/Letter Grade Option.

ESL 054 C Intermediate Oral Skills 2 Units*Prerequisite: Completion of ESL 080 C or appropriate skills demonstrated through the assessment process.*

Term hours: 32–36 lecture. This course is designed for intermediate level non-native English speakers to improve oral communication skills related to social, vocational, and academic areas. The emphasis is on conversation, small group discussion, informal speeches, class discussion and listening comprehension. Non-Degree Credit. May be taken for credit 2 times. Pass/No Pass/Letter Grade Option.

ESL 062 C Advanced ESL Grammar 1 3 Units*Prerequisite: Completion of ESL 083 C or appropriate skills demonstrated through the assessment process.*

Term hours: 48–54 lecture. This course is designed to increase students' knowledge and usage of advanced English grammar, to review grammar trouble spots according to individual and class needs, and to improve grammatical accuracy and editing skills in writing. Non-Degree Credit. Pass/No Pass/Letter Grade Option.

ESL 063 C Advanced ESL Grammar 2 3 Units*Prerequisite: Completion of ESL 083 C or appropriate skills demonstrated through the assessment process.*

Term hours: 48–54 lecture. This course is designed to continue to increase students' knowledge and usage of advanced English grammar, to review grammar trouble spots according to individual and class needs, and to improve grammatical accuracy and editing skills in writing. Non-Degree Credit. Pass/No Pass/Letter Grade Option.

ESL 064 C Advanced Oral Skills 2 Units

Formerly ESL 076 C.

Prerequisite: Completion of ESL 083 C or appropriate skills demonstrated through the assessment process.

Term hours: 32–36 lecture. This course is designed for advanced level non-native English speakers to improve oral communication skills related to social, vocational, and academic areas. The emphasis is on conversation, small group discussion, informal and formal speeches, class discussion and listening comprehension. Non-Degree Credit. May be taken for credit 2 times. Pass/No Pass/Letter Grade Option.

ESL 066 C Advanced ESL Reading 3 Units

Term hours: 48–54 lecture. This reading skills course is designed for non-native speaking students eligible for advanced ESL courses who need to improve their college academic and non-academic reading skills. It does not meet the reading proficiency requirement for the AA degree. Non-Degree Credit. Pass/No Pass/Letter Grade Option.

ESL 080 C Low Intermediate ESL 1 5 Units*Prerequisite: Appropriate skills demonstrated through the assessment process.*

Term hours: 80–90 lecture. This is a low intermediate integrated skills course designed to improve the reading, grammar, writing, listening comprehension, and speaking skills of non-native speakers with a basic command of English. Non-Degree Credit. Pass/No Pass/Letter Grade Option.

ESL 081 C Low Intermediate ESL 2 5 Units*Prerequisite: ESL 080 C with a grade of "C" or better or appropriate skills demonstrated through the assessment process.*

Term hours: 80–90 lecture. This is a low intermediate (Level 1) integrated skills course designed to improve the reading, grammar, writing, listening comprehension, and speaking skills of non-native speakers with a basic command of English. Non-Degree Credit. Pass/No Pass/Letter Grade Option.

ESL 082 C Intermediate ESL 1 5 Units*Prerequisite: ESL 081 C or appropriate skills demonstrated through the assessment process.*

Term hours: 80–90 lecture. This is an intermediate integrated skills course designed to improve the reading, composition, grammar, listening comprehension, and speaking skills of non-native speakers with a moderate command of English. Non-Degree Credit. Pass/No Pass/Letter Grade Option.

ESL 083 C Intermediate ESL 2 5 Units*Prerequisite: ESL 082 C or appropriate skills demonstrated through the assessment process.*

Term hours: 80–90 lecture. This is an intermediate integrated skills course designed to improve the reading, composition, grammar, listening comprehension, and speaking skills of non-native speakers with a moderate command of English. Non-Degree Credit. Pass/No Pass/Letter Grade Option.

ESL 098 C Seminar/Non-Native Speakers — English .5 to 12 Units*Prerequisite: May be required.**Corequisite: May be required.**Advisory: May be required.*

Term hours: 0–216 lecture and/or 0–432 laboratory depending on units attempted. This is a course for advanced ESL students who have completed all regular courses and wish to pursue in small group instruction additional course work in one or more of the language skills: listening, speaking, reading, writing and/or culture. Fees may be required — Payable at Registration. May be taken for credit 1–4 times. Pass/No Pass or Pass/No Pass/Letter Grade Option or Standard Letter Grade.

ESL 099 C Independent Study/Non-Native Speakers .5 to 2 Units*Prerequisite: Approved Independent Study Learning Contract.*

Term hours: Two hours conference per week and appropriate number of laboratory hours for maximum credit. This is a course designed for advanced ESL students who have completed all regular courses and wish to pursue additional coursework in one or more of the language skills: listening, speaking, reading, writing and/or culture. May be taken for credit 3 times. Pass/No Pass only.

ESL 184 C Advanced ESL 1 **5 Units**

Prerequisite: ESL 083 C or appropriate skills demonstrated through the assessment process.

Term hours: 80–90 lecture. This course is an advanced integrated ESL skills course designed to improve the reading, writing, grammar, listening comprehension, and speaking skills of non-native speakers with an advanced command of English. (UC Credit Limitation/CSU)

ESL 185 C Advanced ESL 2 **5 Units**

Prerequisite: ESL 184 C or appropriate skills demonstrated through the assessment process.

Term hours: 80–90 lecture. This course is an advanced integrated ESL skills course designed to improve the reading, writing, grammar, listening comprehension, and speaking skills of non-native speakers with an advanced command of English. (UC Credit Limitation/CSU)

ESL 186 C Advanced ESL Writing **5 Units**

Prerequisite: ESL 185 C with a grade of "C" or better or appropriate skills demonstrated through the assessment process.

Term hours: 80–90 lecture. This course is designed for the non-native speaker of English as an introduction to college level writing skills. Emphasis is on essay development of expository writing. There is practice in reading essays and a novel. The fundamentals of English written expression are reviewed with emphasis on standard American usage problematic to the ESL student. The course is designed to prepare students for ENGL 100 C. (UC Credit Limitation/CSU)

ESL 298 C English as a Second Language Seminar **.5 to 12 Units**

Prerequisite: May be required.

Corequisite: May be required.

Advisory: May be required.

Term hours: 0–216 lecture and/or 0–432 laboratory depending on units attempted. This seminar is for able students who wish to extend their knowledge of literature, language and culture through small group discussion. Fees may be required — Payable at Registration. May be taken for credit 1–4 times. Pass/No Pass or Pass/No Pass/Letter Grade Option or Standard Letter Grade. (UC Credit Limitation/CSU)

Ethnic Studies

Division of Social Sciences

Division Dean — Nina DeMarkey

Faculty

Daniel Lind

Counselors

Velia Lawson

Therese Mosqueda-Ponce

Daniel Pelletier

PROGRAM LEARNING OUTCOMES (PLOs)

The courses taught by this department contribute to the General Education and Basic Skills Program Learning Outcomes. Please refer to General Education and Basic Skills Program Learning Outcomes.

ASSOCIATE IN ARTS DEGREE AFRICAN-AMERICAN STUDIES

Program Code: 1A19682

The Associate in Arts Degree in African-American Studies is designed to provide students with a multi-disciplinary and interdisciplinary examination of the experiences of persons of African descent in the United States. Students will analyze issues pertaining to the African-American community in particular while holistically developing a critical understanding of race, ethnicity, class, and gender in American society. To earn an Associate Degree students must complete: (1) all major course requirements with a minimum grade of "C"; (2) California State University General Education Breadth requirements (CSU GE Breadth) or IGETC general education plan; (3) any elective courses to complete a minimum of 60 units; (4) complete all graduation requirements; and (5) have an overall GPA of 2.0. At least 50% of all major course work must be completed at Cypress College. Students pursuing more than one specified departmental/area major may double count a maximum of 7 units to fulfill major requirements. Courses that fulfill major requirements for an Associate Degree at Cypress College might not be the same as those required for completing the major at a transfer institution offering a Baccalaureate Degree. For information on specific university requirements, please consult with your counselor, or visit the Transfer Center.

Required courses (12 units):		Units
ETHS 101 C	American Ethnic Studies	3
	or	
ETHS 101HC	Honors American Ethnic Studies	(3)
ETHS 129 C	Intro to African-American Studies	3
ETHS 130 C	African-American History I	3
ETHS 131 C	African-American History II	3

Three (3) units from the following elective courses related to the African-American experience:

	Units	
ENGL 255 C	African-American Literature I	3
ENGL 256 C	African-American Literature II	3
ETHS 235 C	The Civil Rights Movement	3
HIST 135 C	African History	3
MUS 113 C	Jazz History	3
POSC 209 C	Urban Politics	3

Three (3) units from the following elective courses:

	Units	
ETHS 150 C	Intro to Chicana/o Studies	3
ETHS 151 C	Chicana/o History I	3
ETHS 152 C	Chicana/o History II	3
ETHS 153 C	Chicana/o Contemporary Issues	3
ETHS 160 C	Native American History	3
ETHS 170 C	Intro to Asian Pacific American Studies	3
ETHS 171 C	Asian Pacific American History	3

Total Units **18**

**ASSOCIATE IN ARTS DEGREE
CHICANA/O STUDIES Program Code: 1A19606**

The Associate in Arts Degree in Chicana/o Studies is designed to provide students with a multi-disciplinary and interdisciplinary examination of the experiences of persons of Mexican descent in the United States. Students will analyze issues pertaining to the Chicana/o (Mexican-American) community in particular while holistically developing a critical understanding of race, ethnicity, class, and gender in American society. To earn an Associate Degree students must complete: (1) all major course requirements with a minimum grade of “C”; (2) California State University General Education Breadth requirements (CSU GE Breadth) or IGETC general education plan; (3) any elective courses to complete a minimum of 60 units; (4) complete all graduation requirements; and (5) have an overall GPA of 2.0. At least 50% of all major course work must be completed at Cypress College. Students pursuing more than one specified departmental/area major may double count a maximum of 7 units to fulfill major requirements. Courses that fulfill major requirements for an Associate Degree at Cypress College might not be the same as those required for completing the major at a transfer institution offering a Baccalaureate Degree. For information on specific university requirements, please consult with your counselor, or visit the Transfer Center.

Required courses (15 units):		Units
ETHS 101 C	American Ethnic Studies	3
	or	
ETHS 101HC	Honors American Ethnic Studies	(3)
ETHS 150 C	Intro to Chicana/o Studies	3
ETHS 151 C	Chicana/o History I	3
ETHS 152 C	Chicana/o History II	3
ETHS 153 C	Chicana/o Contemporary Issues	3
Three (3) units from the following elective courses:		Units
ANTH 225 C	Cultures of Mesoamerica	3
ART 216 C	Latin American Art	3
ETHS 129 C	Intro to African-American Studies	3
ETHS 130 C	African-American History I	3
ETHS 131 C	African-American History II	3
ETHS 160 C	Native American History	3
ETHS 170 C	Intro to Asian Pacific American Studies	3
ETHS 171 C	Asian Pacific American History	3
HIST 142 C	History of Latin America I	3
HIST 143 C	History of Latin America II	3
HIST 162AC	History of the Americas	3
HIST 162BC	History of the Americas	3
HIST 163 C	History of Mexico	3
HIST 275 C	History of California	3
	Total Units	18

**ASSOCIATE IN ARTS DEGREE
ETHNIC STUDIES Program Code: 1A03807**

The Associate in Arts Degree in Ethnic Studies is designed to provide students with a comparative, multi-disciplinary, and interdisciplinary understanding of the experiences of African Americans, Asian Pacific Americans, Chicanos/Latinos, and Native Americans. Students study the histories, cultures, literatures, and politics of communities of color in the United States so that they can critically analyze issues pertaining to race, ethnicity, class, and gender while developing an appreciation for the cultural diversity of American society. To earn an Associate Degree students must complete: (1) all major course requirements with a minimum grade of “C”; (2) California State University General Education Breadth requirements (CSU GE Breadth) or IGETC general education plan; (3) any elective courses to complete a minimum of 60 units; (4) complete all graduation requirements; and (5) have an overall GPA of 2.0. At least 50% of all major course work must be completed at Cypress College. Students pursuing more than one specified departmental major may double count a maximum of 7 units to fulfill major requirements. Courses that fulfill major requirements for an Associate Degree at Cypress College might not be the same as those required for completing the major at a transfer institution offering a Baccalaureate Degree. For information on specific university requirements, please consult with your counselor, or visit the Transfer Center.

Required courses (15 units):		Units
ETHS 101 C	American Ethnic Studies	3
	or	
ETHS 101HC	Honors American Ethnic Studies	(3)
ETHS 129 C	Intro to African-American Studies	3
ETHS 150 C	Intro to Chicana/o Studies	3
ETHS 160 C	Native American History	3
ETHS 170 C	Intro to Asian Pacific American Studies	3
Three (3) units from the following elective courses:		Units
ANTH 121 C	Native North America	3
ANTH 225 C	Cultures of Mesoamerica	3
ART 216 C	Latin American Art	3
ENGL 208 C	Asian-American Literature	3
ENGL 247 C	Multicultural Literature	3
ENGL 255 C	African-American Literature I	3
ENGL 256 C	African-American Literature II	3
ETHS 130 C	African-American History I	3
ETHS 131 C	African-American History II	3
ETHS 151 C	Chicana/o History I	3
ETHS 152 C	Chicana/o History II	3
ETHS 153 C	Chicana/o Contemporary Issues	3
ETHS 171 C	Asian Pacific American History	3
ETHS 235 C	The Civil Rights Movement	3
HIST 135 C	African History	3
HIST 142 C	History of Latin America I	3
HIST 143 C	History of Latin America II	3
HIST 160 C	Asian Civilizations I	3
HIST 161 C	Asian Civilizations II	3
HIST 163 C	History of Mexico	3
HIST 275 C	History of California	3
POSC 209 C	Urban Politics	3
PSY 237 C	Cross-Cultural Relationships	3
	or	
SOC 237 C	Cross-Cultural Relationships	(3)
THEA 107 C	Diversity in American Theater	3
	or	
THEA 107HC	Honors Diversity in American Theater	(3)
	Total Units	18

ETHNIC STUDIES TRANSFER PROGRAM

Students should consult a counselor or www.assist.org for lower division major requirements for most California public universities. (See the Standard Definitions section of the catalog for a description of ASSIST.) Students transferring to an independent college/university should consult the catalog of the individual school and a counselor for lower division major requirements.

Ethnic Studies (ETHS)**ETHS 101 C American Ethnic Studies 3 Units**

Formerly ETHS 100 C.

Advisory: Eligibility for ENGL 100 C.

Term hours: 48–54 lecture. This course serves to broaden the ethnic and racial perspective of students interested in American culture and society. It encompasses an historical overview of the social, cultural, political, and economic aspects of four ethnic groups — Native Americans, African Americans, Chicanos, and Asian Pacific Americans — in the United States. Emphasis is placed on the historical and contemporary relationships of these groups with each other and the rest of American society. Duplicate credit not granted for ETHS 101HC. (UC Credit Limitation/CSU, AA GE, CSU GE, IGETC, CUL DIV)

ETHS 101HC Honors American Ethnic Studies 3 Units

Formerly ETHS 100HC.

Advisory: Eligibility for ENGL 100 C.

Term hours: 48–54 lecture. This course serves to broaden the ethnic and racial perspective of students interested in American culture and society. It is an enhanced historical study of the social, cultural, political, and economic aspects of four ethnic groups — Native Americans, African Americans, Chicanos, and Asian Pacific Americans — in the United States. Emphasis is placed on the historical and contemporary relationships of these groups with each other and the rest of American society. Duplicate credit not granted for ETHS 101 C. (UC Credit Limitation/CSU, AA GE, CSU GE, IGETC, CUL DIV)

ETHS 129 C Introduction to African-American Studies 3 Units

Advisory: Eligibility for ENGL 100 C.

Term hours: 48–54 lecture. This course is an introduction to the field of African-American Studies. An interdisciplinary approach will be employed to study the various experiences of African Americans and their contributions to American society and culture. The course will cover historical and contemporary issues, including African origins, the development of African-American culture, the struggles of the black family, black political life, and the socio-economic empowerment of black people in the United States. (UC/CSU, AA GE, CSU GE, IGETC, CUL DIV)

ETHS 130 C African-American History I 3 Units

Advisory: Eligibility for ENGL 100 C.

Term hours: 48–54 lecture. This course is a survey of the African-American experience in the United States from its African roots through the American Civil War, emphasizing the roles of African Americans in the political, social, and economic development of American society. Topics covered include: the trans-Atlantic slave trade; the process of enslavement in the Americas; slave life and resistance; the socio-economic conditions of free blacks; the politico-economic dispute regarding slavery and its consequences in the outbreak of the American Civil War; and the emancipation of the enslaved black population. (UC/CSU, AA GE, CSU GE, IGETC, CUL DIV)

ETHS 131 C African-American History II 3 Units

Advisory: Eligibility for ENGL 100 C.

Term hours: 48–54 lecture. This course is a survey of the African-American experience in the United States from the Era of Reconstruction to the present, emphasizing the roles of African Americans in the political, social and economic development of American society. Topics covered include: the various phases of the Reconstruction period; black life in the “New South”; the debates over educational and socio-economic progress; the migrations to the North and West; the struggles of the black working class; the impact of the two world wars on black life; the Civil Rights Movement; militancy during the 1960s; and the black experience in contemporary America. (UC/CSU, AA GE, CSU GE, IGETC, CUL DIV)

ETHS 150 C Introduction to Chicana/o Studies 3 Units

Advisory: Eligibility for ENGL 100 C.

Term hours: 48–54 lecture. This course is an introduction to the field of Chicana/o Studies. It is designed to acquaint students with the most significant social, political, economic, and historical aspects of the Chicana/o experience in the United States. As such, the course is interdisciplinary in nature and critically analyzes the societal content in which Chicanas/os have sought to maintain their culture. (UC/CSU, AA GE, CSU GE, IGETC, CUL DIV)

ETHS 151 C Chicana/o History I 3 Units

Advisory: Eligibility for ENGL 100 C.

Term hours: 48–54 lecture. This course is a survey of the Chicana/o experience from the pre-European conquest era of North America to the Mexican-American War. Topics covered include: Mesoamerican civilizations; Spanish conquest and settlement in the Americas; the rise of “mestizaje” among the indigenous populations, Spaniards, and Africans in Mexico and the North American Southwest; life in the Spanish and Mexican borderlands prior to the American conquest; and the War between the United States and Mexico. (UC/CSU, AA GE, CSU GE, IGETC, CUL DIV)

ETHS 152 C Chicana/o History II 3 Units

Advisory: Eligibility for ENGL 100 C.

Term hours: 48–54 lecture. This course is a survey of the Chicana/o experience from the Mexican-American War to the present. Topics covered include: the impact of the Mexican-American War on the lives of Mexicans in the American Southwest during the nineteenth century; immigration, labor struggles, and racial discrimination during the twentieth century; the struggles for civil rights and social equality; cultural affirmation and the construction of a “Chicana/o” identity; and the Chicana/o experience in contemporary America. (UC/CSU, AA GE, CSU GE, IGETC, CUL DIV)

ETHS 153 C Chicana/o Contemporary Issues 3 Units

Advisory: Eligibility for ENGL 100 C.

Term hours: 48–54 lecture. This course focuses on the contemporary issues, characteristics, and significant contributions of the Chicana/o community. Emphasis is placed on contemporary sociological systems including, but not limited to, education, politics, social welfare, criminal justice, and the family. Some field study and research work may be required to provide relevant experiences. (UC/CSU, CSU GE, IGETC, CUL DIV)

ETHS 160 C Native American History 3 Units

Advisory: Eligibility for ENGL 100 C.

Term hours: 48–54 lecture. This course is an historical examination of the native peoples of the Americas from their early beginnings to the present. Emphasis is placed on the relations between Native Americans and other peoples in the United States. A socio-cultural approach is utilized to develop a thorough understanding of the Native American experience. (UC/CSU, AA GE, CSU GE, IGETC, CUL DIV)

ETHS 170 C Introduction to Asian Pacific American Studies**3 Units***Advisory: Eligibility for ENGL 100 C.*

Term hours: 48–54 lecture. This course is an introduction to the field of Asian Pacific American Studies. An interdisciplinary approach will be employed to study the experiences of various Asian and Pacific Islander groups in the United States, utilizing the perspectives of race, nationality, class, gender, and sexuality. The course will cover historical and contemporary issues within Asian Pacific American communities, including immigration, anti-Asian violence, labor, unionization, and stereotypes. (UC/CSU, AA GE, CSU GE, IGETC, CUL DIV)

ETHS 171 C Asian Pacific American History**3 Units***Advisory: Eligibility for ENGL 100 C.*

Term hours: 48–54 lecture. This course is a survey of the Asian Pacific American experience in the United States from the mid-nineteenth century to the present. It addresses the historical forces that affected Asian Pacific American communities including: Chinese, Japanese, Filipino, Korean, Hawaiian, South Asian, and Southeast Asian. Topics covered include: Asian and Pacific Islander origins; immigration and settlement patterns; labor struggles and community formation; racism and U.S. exclusionary policies; the struggles for inclusion and civil rights; and the Asian Pacific American experience in contemporary America. (UC/CSU, AA GE, CSU GE, IGETC, CUL DIV)

ETHS 235 C The Civil Rights Movement**3 Units**

Term hours: 48–54 lecture. This course will explore the principal factors that gave rise to the Civil Rights Movement of the 1950s and 1960s. Sociological models of collective behavior and social movements are utilized to analyze social structures, existing conditions, leadership, goals and tactics, organization, successes and failures and long term results of the Movement. (UC/CSU, CSU GE, CUL DIV)

ETHS 298 C Ethnic Studies Seminar**.5 to 12 Units***Prerequisite: May be required.**Corequisite: May be required.**Advisory: May be required.*

Term hours: 0–216 lecture and 0–432 laboratory depending on units attempted. This is a lecture/discussion course focusing on a particular limited problem or topic of interest to students. It is designed for students who wish to increase their knowledge of a particular topic concerning which no other regular class is offered. A paper or group activity may be requested. Consult the class schedule for the offerings in a particular semester. May be taken for credit 1–4 times. Pass/No Pass or Pass/No Pass/Letter Grade Option or Standard Letter Grade. Fees may be required — Payable at Registration. (UC Credit Limitation/CSU)

ETHS 299 C Ethnic Studies Independent Study**1 Unit***Prerequisite: Dean Approved Independent Study Learning Contract.*

Term hours: 16–18 lecture. Independent study is for students who wish to extend their knowledge of a particular area through individual research and study. It is thought that topics might develop out of a curiosity stimulated in a regular class. The student would then contact the supervising instructor to develop a contract for his/her particular interest so he/she could learn more regarding their special topic. May be taken for credit 4 times. (UC Credit Limitation/CSU)

**Flight Attendant —
See Airline and Travel Careers (ATC)**

Foreign Language

For specific foreign language courses see Chinese, Japanese, French and Spanish.

FOREIGN LANGUAGE TRANSFER PROGRAM

Students should consult a counselor or www.assist.org for lower division major requirements for most California public universities. (See the Standard Definitions section of the catalog for a description of ASSIST.) Students transferring to an independent college/university should consult the catalog of the individual school and a counselor for lower division major requirements.

Forestry

FORESTRY TRANSFER PROGRAM**CALIFORNIA STATE UNIVERSITY, HUMBOLDT**

Students should consult a counselor or www.assist.org for lower division major requirements for most California public universities. (See the Standard Definitions section of the catalog for a description of ASSIST.) Students transferring to an independent college/university should consult the catalog of the individual school and a counselor for lower division major requirements.

French

Division of Language Arts*Division Dean* — Eldon Young*Counselors*

Velia Lawson

Therese Mosqueda-Ponce

Daniel Pelletier

PROGRAM LEARNING OUTCOMES (PLOs)

The courses taught by this department contribute to the General Education and Basic Skills Program Learning Outcomes. Please refer to General Education and Basic Skills Program Learning Outcomes.

French (FREN)

FREN 053 C Basic Spoken French**3 Units**

Term hours: 48–54 lecture. This is an introductory course emphasizing oral practice, pronunciation, and vocabulary development. It is designed to develop a speaking knowledge of French for use in everyday conversational situations. It is an ideal preparation for college-level language classes for students with limited language skills. It is not open to native speakers of the language. May be taken for credit 2 times. Pass/No Pass/Letter Grade Option.

FREN 098 C French Seminar**.5 to 12 Units***Prerequisite: May be required.**Corequisite: May be required.**Advisory: May be required.*

Term hours: 0–216 lecture and/or 0–432 laboratory depending on units attempted. This seminar is for students who wish to extend their knowledge of literature, language and culture through small group discussion. May be taken for credit 1–4 times. Pass/No Pass or Pass/No Pass/Letter Grade Option or Standard Letter Grade. Fees may be required — Payable at Registration.

FREN 101 C Elementary French I**5 Units**

Term hours: 80–90 lecture. The course emphasizes the acquisition of basic skills in pronunciation, listening, speaking, reading, and writing. Students will be introduced to the culture, history, and geography of France and other French-speaking countries through lectures, films, video, DVD, CD-ROM, Internet sites, and reading assignments. Pass/No Pass/Letter Grade Option. (UC/CSU, AA GE, CSU GE, IGETC)

FREN 102 C Elementary French II**5 Units***Prerequisite: FREN 101 C with a minimum grade of "C" or better or one year of high school French with an average grade of "C" or better.*

Term hours: 80–90 lecture. The course continues to emphasize the acquisition of basic skills in pronunciation, listening, speaking, reading, and writing. Students will increase their knowledge of the culture, history, and geography of France through lectures, slides, films, and reading and writing assignments. Pass/No Pass/Letter Grade Option. (UC/CSU, AA GE, CSU GE, IGETC)

FREN 200 C Conversational French**2 Units***Prerequisite: FREN 102 C.*

Term hours: 32–36 lecture. This is a course in conversation with emphasis on the idiomatic use of the language through French films. Topics concern French life, culture, geography, and history. Students prepare for this class through the study of the textbook, magazines, newspapers, and other current material and encounters. This course is conducted in French. May be taken for credit 4 times. Pass/No Pass/Letter Grade Option. (CSU, CSU GE)

FREN 203 C Intermediate French III**4 Units***Prerequisite: FREN 102 C with a grade of "C" or better or two years of high school French with an average grade of "C" or better.*

Term hours: 64–72 lecture. The course emphasizes the acquisition of contextualized vocabulary and grammatical information to develop speaking, reading and writing skills. New cultural, historic and literary material is introduced through lectures, films, Internet sites, reading and writing assignments. This course is conducted in French. Pass/No Pass/Letter Grade Option. (UC/CSU, AA GE, CSU GE, IGETC)

FREN 204 C Intermediate French IV**4 Units***Prerequisite: FREN 203 C with grade of "C" or better or three years of high school French with an average grade of "C" or better.*

Term hours: 64–72 lecture. The course emphasizes the mastery and application of grammatical rules. It requires more advanced reading of modern and classical French, as well as a continued emphasis on oral and written expression. It is designed to help the student acquire a working knowledge of the language and to form the basis for advanced work in literature and science. Continued readings and discussions of francophone life and culture are an essential factor. Pass/No Pass/Letter Grade Option. (UC/CSU, AA GE, CSU GE, IGETC)

FREN 298 C French Seminar**.5 to 12 Units***Prerequisite: May be required.**Corequisite: May be required.**Advisory: May be required.*

Term hours: 0–216 lecture and/or 0–432 laboratory depending on units attempted. This seminar is for able students who wish to extend their knowledge of literature, language and culture through small group discussion. Fees may be required — Payable at Registration. May be taken for credit 1–4 times. Pass/No Pass or Pass/No Pass/Letter Grade Option or Standard Letter Grade. (UC Credit Limitation/CSU)

FREN 299 C French Independent Study**.5 to 2 Units***Prerequisite: Approved Independent Study Learning Contract.*

Two hours conference per week for maximum credit. This course is designed for able students who wish to increase their knowledge of the French language through individual study or research. May be taken for credit 3 times. Pass/No Pass/Letter Grade Option. (UC Credit Limitation/CSU)

FRENCH TRANSFER PROGRAM

Students should consult a counselor or www.assist.org for lower division major requirements for most California public universities. (See the Standard Definitions section of the catalog for a description of ASSIST.) Students transferring to an independent college/university should consult the catalog of the individual school and a counselor for lower division major requirements.

Geography

Division of Social Sciences

*Division Dean, Nina DeMarkey**Faculty*

Leslie Doak

Armando Mendoza

Counselors

Velia Lawson

Therese Mosqueda-Ponce

Daniel Pelletier

PROGRAM LEARNING OUTCOMES (PLOs)

The courses taught by this department contribute to the General Education and Basic Skills Program Learning Outcomes. Please refer to General Education and Basic Skills Program Learning Outcomes.

GEOGRAPHIC INFORMATION SYSTEMS

CERTIFICATE

Program Code: 1C07825

Provide endorsed entry-level skills for the rapidly growing GIS field. Our certificate is the only general purpose GIS certificate approved by the California State Chancellor's office.

To earn a certificate, students must complete the required courses as listed with a minimum grade of "C." At least 50% of all course work must be completed at Cypress College. College certificate is inclusive of tiers one through four in the U.S. Department of Labor's Geospatial Industry Competency Model of June 1, 2010.

Geographic Information Systems (12 units) required:

Course #	Title	Units
GEOG 230 C	Introduction to GIS	3
GEOG 231 C	GIS: Vector Applications	3
GEOG 232 C	GIS: Advanced Vector and Raster	3
GEOG 233 C	GIS: Advanced Applications	3

Spatial Courses (3 units) from the following:

GEOG 100 C	World Geography	3
*GEOG 160 C	Cultural Geography	3

Spatially Related Courses (3 units) from the following:

ANTH 102 C	Cultural Anthropology	3
ANTH 203 C	Introduction to Archaeology	3
BIOL 103 C	Human Ecology	3
BIOL 122 C	Marine Biology	5
BIOL 127 C	Natural History	5
BIOL 128 C	Plants and Society	5
BIOL 176 C	Ecology	3
ECON 260 C	Economic Geography	3
ENGT 101 C	Technical Drawing	3
ENGT 104 C	Computer Aided Design	3
GEOG 100 C	World Geography	3
GEOG 102 C	Physical Geography	3
GEOG 130 C	California Geography	3
GEOG 140 C	Weather and Climate	3
*GEOG 160 C	Cultural Geography	3
GEOG 202 C	Field Geography — Physical	1
GEOG 234 C	Current Topics in GIS	3
GEOG 260 C	Economic Geography	3
GEOL 100 C	Physical Geology	3
GEOL 120 C	Geology of California	3
GEOL 130 C	Introduction to Oceanography	3
GEOL 190 C	Environmental Geology	3
HS 147 C	Survey of Disease	3
ATC 174 C	Destinations: Americas/Europe	3
ATC 175 C	Destinations: Africa/Pacific	3
MKT 222 C	Principles of Marketing	3
MKT 224 C	International Marketing	3
ASTR 116 C	Introduction to Astronomy	3

Spatial Course with Lab (4 units) from the following:

GEOG 102 C	Physical Geography	3
GEOG 102LC	Physical Geography — Lab	1
GEOL 100 C	Physical Geology	3
GEOL 101 C	Physical Geology Laboratory	1
GEOG 202 C	Field Geography — Physical	1

Computer Programming Skills: (3 units) from the following:

CIS 211 C	Introduction to Programming	3
CIS 229 C	Intro to XML Programming	3
CIS 236 C	Intro to Oracle: SQL and PL/SQL	3
CIS 247 C	Python Programming	3

Total Units 25

*A score of 3 or higher on the Advanced Placement (AP) Geography (Human) exam meets this requirement upon petition through Admissions and Records. See a counselor for more information.

ASSOCIATE IN ARTS DEGREE

GEOGRAPHY

Program Code: 1A19681

The Associate in Arts Degree in Geography is designed to provide students with a comprehensive introduction to the three distinct areas of geographic studies (Earth Science/Environmental Studies/Physical; Earth Technologies; and Human Studies) in order to give them the background knowledge needed by undergraduate geography majors for university transfer and coursework, while emphasizing the practical applications of geographic skills and knowledge in a diversity of careers and the utility of geographic perspectives as a life-long learning

tool for interpreting our world's complex systems and world events. To earn an Associate Degree, students must complete: (1) all major course requirements with a minimum grade of "C"; (2) California State University General Education Breadth requirements (CSU GE Breadth) or IGETC general education plan; (3) any elective courses to complete a minimum of 60 units; (4) complete all graduation requirements; and (5) have an overall GPA of 2.0. At least 50% of all major course work must be completed at Cypress College. Students pursuing more than one specified departmental major may double count a maximum of 7 units to fulfill major requirements. Courses that fulfill major requirements for an Associate Degree at Cypress College might not be the same as those required for completing the major at a transfer institution offering a Baccalaureate Degree. For information on specific university requirements, please consult with your counselor, or visit the Transfer Center.

Required courses (13 Units):

Course #	Title	Units
GEOG 100 C	World Geography	3
	or	
GEOG 100HC	Honors World Geography	(3)
GEOG 102 C	Physical Geography	3
GEOG 102LC	Physical Geography Lab	1
*GEOG 160 C	Cultural Geography	3
GEOG 130 C	California Geography	3

Elective courses (6 Units):

Course #	Title	Units
GEOG 140 C	Weather and Climate	3
GEOG 260 C	Economic Geography	3
GEOG 202 C	Field Geography — Physical	1
ANTH 104 C	Comparative Cultures	3
POSC 230 C	International Relations	3
HIST 112 C	World Civilizations I	3

Total Units Required 19

*A score of 3 or higher on the Advanced Placement (AP) Geography (Human) exam meets this requirement upon petition through Admissions and Records. See a counselor for more information.

GEOGRAPHIC INFORMATION SYSTEMS/MARKETING

CERTIFICATE

Program Code: 1K12953

This certificate program provides students with the skills to use Geographic Information Systems (GIS) computerized mapping techniques in the field of marketing. Combining the latest computer graphics and marketing research methods, students will learn to create maps to locate customers, evaluate business sites, plan distribution networks and sales territories, and find new business opportunities.

To earn a certificate, students must complete the required courses as listed with a minimum grade of "C." At least 50% of all course work must be completed at Cypress College.

Required courses are listed in suggested sequence:

Course #	Title	Units
MKT 222 C	Principles of Marketing	3
MKT 210 C	Consumer Behavior	3
MKT 224 C	International Marketing	3
GEOG 230 C	Introduction to GIS	3
GEOG 231 C	GIS: Vector Applications	3

Total Units Required 15

GEOGRAPHY TRANSFER PROGRAM

Students should consult a counselor or www.assist.org for lower division major requirements for most California public universities. (See the Standard Definitions section of the catalog for a description of ASSIST.) Students transferring to an independent college/university should consult the catalog of the individual school and a counselor for lower division major requirements.

Geography (GEOG)

GEOG 100 C World Geography 3 Units

Term hours: 48–54 lecture. An introduction to today's physical and political regions emphasizing location, population, political status, land use problems and potentialities and providing opportunities for worldwide research. Duplicate credit not granted for GEOG 100HC. (UC Credit Limitation/CSU, AA GE, CSU GE, IGETC)

GEOG 100HC Honors World Geography 3 Units

Term hours: 48–54 lecture. An enhanced introduction to today's physical and political regions emphasizing location, population, political and economic status, differences and similarities, problems and potentialities and providing opportunities for worldwide research. Duplicate credit not granted for GEOG 100 C. (UC Credit Limitation/CSU, AA GE, CSU GE, IGETC)

GEOG 102 C Physical Geography 3 Units

Term hours: 48–54 lecture. This course is an investigation and interpretation of the sun-earth relationship, science maps, weather and climate, the hydrosphere, cycles and patterns in the biosphere, flora and fauna, soils, rocks, and minerals, weathering, mass wasting, erosion, and origin and types of landforms that provide insight into the nature of man's physical environment. (UC/CSU, AA GE, CSU GE, IGETC)

GEOG 102LC Physical Geography — Lab 1 Unit

Prerequisite: Completion of, or concurrent enrollment in, GEOG 102 C.
Term hours: 32–36 laboratory and 16–18 laboratory/quiz/problem solving. This course investigates and interprets in a laboratory environment the sun-earth relationships, science of maps, weather and climate, climatic types and locations, natural vegetation, soils and minerals, ocean environment, and the origin and types of landforms that provide insight into the nature of man's physical environment. (UC/CSU, AA GE, CSU GE, IGETC)

GEOG 130 C California Geography 3 Units

Term hours: 48–54 lecture. This course investigates and interprets the physical, cultural and economic bases and regions of the state of California. Particular emphasis is placed upon the natural foundations of the landscape with the exploration of the unique nature and special characteristics of the people utilizing that landscape. (UC/CSU, CSU GE, IGETC)

GEOG 140 C Weather and Climate 3 Units

Term hours: 48–54 lecture. This course is an investigation and interpretation of the local and global surface weather phenomena, use of instrument, classification and distribution of world climates. Particular emphasis is placed upon the interrelationships between weather and climate and upon weather forecast techniques. (UC/CSU, CSU GE, IGETC)

GEOG 160 C Cultural Geography 3 Units

Term hours: 48–54 lecture. This course investigates and interprets the interrelationship of human activities with cultural background, physical environment and the diffusion of ideas. Emphasis is placed on where and why people locate, the distribution of different cultural characteristics on the earth's surface, how people earn a living in various parts of the world, how people organize their lives and how their problems may result from the use of the earth's resources. (UC/CSU, AA GE, CSU GE, IGETC)

GEOG 202 C Field Geography — Physical 1 Unit

Prerequisite: Completion of or concurrent enrollment in GEOG 102 C.
Term hours: 18 lecture in the field (location TBA). Each separate offering of this course will occur in a unique location, studying unique circumstances and conditions in the field. Each course will employ its own combination of technical equipment, scientific instruments, and geotechniques. All courses will study the basic conceptual materials, with modifications associated with the location and the specific conditions encountered at each season. May be taken for credit 4 times. Field trip cost not to exceed \$40.00. (UC/CSU)

GEOG 230 C Introduction to GIS 3 Units

Term hours: 80–90 lecture. This course will introduce the student to Geographic Information Systems technology and software. Students will be taught how to retrieve and apply data in their chosen business and/or academic area of interest. \$4.00 Materials Fee — Payable at Registration. (CSU)

GEOG 231 C GIS: Vector Applications 3 Units

Prerequisite: GEOG 230 C.
Term hours: 89–90 lecture. Geographic Information Systems (such as ArcInfo) is introduced as a tool to analyze and solve problems, and to discover opportunities for business and academic applications. Students will apply this software in student selected projects. A semester project will be required of each student. \$4.00 Materials Fee — Payable at Registration. (CSU)

GEOG 232 C GIS: Advanced Vector and Raster 3 Units

Prerequisite: GEOG 231 C.
Term hours: 32–36 lecture and 48–54 laboratory. This course introduces students to advanced topics, techniques, and analysis in Geographic Information Systems (GIS). Students will retrieve and apply data in their chosen business or academic area of interest. \$4.00 Materials Fee — Payable at Registration. (CSU)

GEOG 233 C GIS: Advanced Applications 3 Units

Prerequisite: GEOG 232 C.
Term hours: 16–18 lecture and 125 hours fieldwork. Internships and fieldwork comprise a significant portion of the students' work in this Geographic Information Systems (GIS) course. Students are required to participate in 125 hours of supervised field study per semester (7 hours per week) and one hour lecture per week to discuss problem areas related to fieldwork. \$4.00 Material Fee — Payable at Registration. (CSU)

GEOG 234 C Current Topics in GIS 3 Units

Term hours: 32–36 lecture and 48–54 laboratory. This is an advanced lecture/discussion project type course designed to cover current issues and advances in Geographic Information Systems. It is designed for students who have experience in GIS applications and wish to update their knowledge and working skills. A final semester project, utilizing GIS for a project chosen by the student will be required. May be taken for credit 4 times. Pass/No Pass/Letter Grade Option. \$4.00 Material Fee — Payable at Bookstore. (CSU)

GEOG 260 C Economic Geography**3 Units**

Same as ECON 260 C.

Term hours: 48–54 lecture. This course is an investigation and interpretation of the world's economic organization, its natural resources, raw materials, crops and crop production, manufacturing and service industries, new trends in producing and the changing centers of production and consumption. (UC/CSU, CSU GE, IGETC)

GEOG 298 C Geography Seminar**.5 to 12 Units***Prerequisite: May be required.**Corequisite: May be required.**Advisory: May be required.*

Term hours: 0–216 lecture and/or 0–756 laboratory. This is a lecture/discussion type course developed on a particular limited problem or topic of interest to students. It is designed for able students who wish to increase their knowledge of a particular topic concerning which no other regular class is offered. A paper or group activity may be requested. Credit may range from .5 units to 12 units. Consult class schedule for the offerings a particular semester. Fees may be required — Payable at Registration. May be taken for credit 1–4 times. Pass/No Pass or Pass/No Pass/Letter Grade Option or Standard Letter Grade. (UC Credit Limitation/CSU)

GEOG 299 C Geography Independent Study**1 Unit***Prerequisite: Approved Independent Study Learning Contract.*

May be taken for credit 3 times.

Varying hours of scheduled conferences per week according to instructor. Independent study is for able students who wish to extend their knowledge of a particular area through individual research and study. It is thought the topics might develop out of a curiosity stimulated in a regular class. The student would then contact the supervising instructor to develop a contract for his/her particular interest so that they could learn more regarding their specific topic. (UC Credit Limitation/CSU)

Geology

Division of Science/Engineering/Mathematics*Division Dean* — Richard Fee*Faculty*

Victoria Castle

Counselor

Deidre Porter

PROGRAM LEARNING OUTCOMES (PLOs)

The courses taught by this department contribute to the General Education and Basic Skills Program Learning Outcomes. Please refer to General Education and Basic Skills Program Learning Outcomes.

GEOLOGY TRANSFER PROGRAMS

Students should consult a counselor or www.assist.org for lower division major requirements for most California public universities. (See the Standard Definitions section of the catalog for a description of ASSIST.) Students transferring to an independent college/university should consult the catalog of the individual school and a counselor for lower division major requirements.

Geology (GEOL)

GEOL 100 C Physical Geology**3 Units**

Term hours: 48–54 lecture. This course is a survey of the composition and structure of the earth, integrating the processes and forces that operate underneath and upon the earth's surface. Duplicate credit not granted for GEOL 100HC or GEOL 102 C. (UC/CSU, AA GE, CSU GE, IGETC)

GEOL 100HC Honors Physical Geology**3 Units**

Term hours: 48–54 lecture. This course is an enhanced introduction to the concepts and theories of geology. This course is a survey of the composition and structure of the earth, integrating the processes and forces that operate underneath and upon the earth's surface. Visits to local natural museums and geological field trips may be arranged. Duplicate credit not granted for GEOL 100 C or GEOL 102 C. (UC/CSU, AA GE, CSU GE, IGETC)

GEOL 101 C Physical Geology Laboratory**1 Unit***Prerequisite: Completion of, or concurrent enrollment in, GEOL 100 C.*

Term hours: 80–90 lecture. This course includes the identification of minerals and rocks; understanding of topographic maps, aerial photographs and other imagery from remote sensing; interpretation of rocks, structures, and geologic processes as revealed on maps, air photos, and satellite imagery and their relationship to plate tectonics. Not open to students with credit in GEOL 102 C. (UC/CSU, AA GE, CSU GE, IGETC)

GEOL 103 C Historical Geology**4 Units**

Term hours: 48–54 lecture and 48–54 laboratory. This course is an introduction to the scientific method of exploring planetary materials and structures in understanding the origin and development of the earth and its organisms through time. Laboratory involves examining and classifying rock and fossil specimens, analyses of rock and fossil records found on and in the earth, and application of rock and fossil interpretations to historical geology. (UC/CSU, AA GE, CSU GE, IGETC)

GEOL 105 C Earth Science for Teachers**4 Units**

Term hours: 48–54 lecture and 48–54 laboratory. This class is designed for the prospective school teacher. This multidisciplinary course will explore the fields of geology, oceanography, meteorology, and astronomy. Topics include solar system, mineral/rock formation, star/galaxy, atmosphere, volcanoes, and earthquakes. (CSU, AA GE, CSU GE)

GEOL 115 C Physical Geology Field Lab**1 Unit**

Term hours: 48–54 lecture. This course includes field and laboratory study of minerals, rock, and fossil identification; structural and geomorphic features; geologic history; and geologic hazards of selected regions in Southern California. Not open to students with credit in GEOL 101 C or GEOL 102 C. (UC Credit Limitation/CSU, AA GE, CSU GE, IGETC)

GEOL 120 C Geology of California**3 Units**

Term hours: 48–54 lecture. This course is designed to acquaint the student with the physical and historical geology of the natural provinces of California. The mineral deposits, stratigraphic and rock units, tectonic structures, fossils and geomorphology within each province will be examined. (UC/CSU, AA GE, CSU GE, IGETC)

GEOL 125 C Natural Disasters**3 Units**

Term hours: 48–54 lecture. This course is an introduction to the science of natural disasters. Topics include earthquakes, volcanoes, landslides, hurricanes, tornadoes, floods, climate change and mass extinctions. Case studies, monitoring methods and disaster planning will be addressed. (UC/CSU, AA GE, CSU GE, IGETC)

GEOL 130 C Introduction to Oceanography**3 Units**

Term hours: 48–54 lecture. This course is a survey of the composition and structure of the earth's ocean showing the interrelationship between atmosphere, hydrosphere, lithosphere, and biosphere. The effects of modern technology, ocean resources, and marine pollution will be explored. Field trips may be required with a fee not to exceed \$25. (UC/CSU, AA GE, CSU GE, IGETC)

GEOL 131 C Introduction to Oceanography Lab**1 Unit**

Prerequisite: Completion of, or concurrent enrollment in, GEOL 130 C.

Term hours: 48–54 lecture. This course includes the identification of earth materials; understanding of bathymetric charts; basic navigation; and methods of oceanographic research. Field trips may be required at no additional cost. (UC/CSU, AA GE, CSU GE, IGETC)

GEOL 190 C Environmental Geology**3 Units**

Term hours: 48–54 lecture. This course is designed for the non-science major and will integrate the significant principles and concepts of the solid earth, atmosphere, space and hydrospace and relate them to the environment, with special emphasis on resources, wastes and hazards. The perspective will focus on ways in which earth processes generate the varieties of resources useful in humans in the form of metal, non-metals, energy, water, ocean and soil. Hazards such as liquid, solid and radioactive wastes and their effects on environmental deterioration will be studied. Natural hazards such as floods, faults, landslides and earthquakes will be examined. The course is not open to students who have completed GEOL 100 C or GEOL 102 C. (UC Credit Limitation/CSU, AA GE, CSU GE, IGETC)

GEOL 298 C Geology Seminar**.5 to 12 Units**

Prerequisite: May be required.

Corequisite: May be required.

Advisory: May be required.

Term hours: 0–216 lecture and/or 0–648 laboratory depending on units attempted. The seminars are designed to enhance and intensify knowledge in a variety of geologic topics. They may include lectures, discussions, and field excursions at the discretion of the instructor. Specific topics for seminars will be listed in the class schedule for a particular semester. May be taken for credit 1–4 times. Pass/No Pass or Pass/No Pass/Letter Grade Option or Standard Letter Grade. Fees may be required — Payable at Registration. (UC Credit Limitation/CSU)

Graphic Arts — See Media Art Design (MAD)

Health Information Technology

Division of Health Science

Division Dean — John Sciacca

Faculty

Rebecca Gomez

Rosalie Majid

Counselors

Kelly Carter

Denise Vo

PROGRAM LEARNING OUTCOMES (PLOs)

Health Information Technology

A student who completes the Health Information Technology program will be able to:

- Gain the knowledge and skills needed to perform entry level functions in health information management technology.
- Attain the knowledge and skills needed to successfully pass entry level HIM certification examinations, especially the Registered Health Information Technician examination.
- Obtain HIM-related positions or be enrolled in an advanced degree program within 6 months of completion of the program.

HEALTH INFORMATION TECHNOLOGY ASSOCIATE IN SCIENCE

DEGREE PROGRAM

Program Code: 1S03788

Courses in Health Information Technology prepare individuals to become health information managers and specialists. Health information technicians are members of the health care team who assure that documentation is consistent with professional standards and licensure requirements. To accomplish this, health information technicians monitor and track information documented in both paper-based and electronic health records — the medical history, physical examination, progress notes reflecting treatment, and laboratory and radiology reports. Interacting with physicians, administrators, nurses, chief information officers, and other allied health professionals, health information technicians quantify, manage, and interpret the health record data that becomes the basis for crucial medical and financial decisions. Health information technicians function as the patient advocate in protecting the confidentiality of protected health information pursuant to the Health Insurance Portability and Accountability Act. To fulfill these responsibilities, health information technicians develop a broad range of skills. Their clinical knowledge base is essential for them to read and interpret the medical record. Processing health information involves usage of computers and computer applications. In safeguarding medical information, the health information technician becomes familiar with the legal aspects inherent in the delivery of patient care. Health information technicians develop managerial skills working as supervisors and directors of health information departments. Most (60%) health information technicians currently work in health care facilities where they organize, analyze and generate health data for treatment, reimbursement, planning, quality assessment and research. Other employers of health information professionals include medical group practices, government agencies, insurance companies, utilization review organizations, health maintenance organizations, cancer centers, consulting firms and Health IT vendors. Health information specialists can also work in sales and

marketing positions for companies that design and supply information systems and materials for health information/medical record departments. The program is accredited by the Commission on Accreditation of Health Informatics and Information Management Education. Graduates of the program are, therefore, eligible to take the national examination leading to certification as a Registered Health Information Technician.

MINIMUM STANDARDS FOR ENROLLMENT

High school graduation, passing of the General Education Development (GED) test or high school proficiency examination.

ENROLLMENT PROCEDURES

1. Students may enroll in either the fall, spring or summer sessions.
2. Submit application to College.
3. Students must furnish all documents and transcripts to the Admissions and Records Office.

REQUIRED CURRICULUM: Transferability of health information coursework is determined by the individual receiving college.

HEALTH INFORMATION TECHNOLOGY

ASSOCIATE IN SCIENCE

DEGREE

Program Code: 1S03788

To earn an Associate Degree students must complete: (1) all major course requirements with a minimum grade of "C"; (2) 25 units of General Education Graduation Requirements with a minimum grade of "C"; (3) the cultural diversity and reading requirements with a minimum grade of "C"; (4) any elective courses to complete a minimum of 60 units; and, (5) have a minimum GPA of 2.0. At least 50% of all major course work must be completed at Cypress College.

HEALTH INFORMATION TECHNOLOGY

CERTIFICATE

Program Code: 1C21113

To earn a certificate, students must (1) document a minimum of an Associate Degree; and (2) complete all major course work with a minimum grade of "C." At least 50% of all major course work must be completed at Cypress College.

REQUIRED CURRICULUM

<i>SUMMER SESSION 1</i>		Units
CIS 111 C	Computer Information Systems	3
HS 145 C	Survey of Medical Terminology	3
HI 100 C	Trends in Health Care Delivery	2
<i>SEMESTER 1</i>		Units
HI 101 C	Health Information Science	3
HI 102 C	Legal Aspects of Health Care	2
BIOL 210 C	Anatomy and Physiology	5
ENGL 100 C	College Writing	3
<i>SEMESTER 2</i>		Units
HS 147 C	Survey of Disease	3
HI 115 C	Medical Staff Services Science	3
HI 204 C	Beginning Coding	3
<i>SEMESTER 3</i>		Units
HI 103 C	Health Care Statistics	3
HI 214 C	CPT/Ambulatory Care Coding	3
HI 203 C	Medical Quality Management	2
HI 105 C***	Directed Practice I	4

<i>SEMESTER 4</i>		Units
HI 220 C	Advanced Coding	3
HI 225 C	Information Technology	3
HI 110 C	Medical Insurance Billing	3
HI 245 C	Coding Skills Lab	1
HI 205 C ***	Directed Practice II	4
Total Units		56–57

***This course is a non-paid laboratory experience. Students are assigned to a health care agency.

ASSOCIATE IN SCIENCE DEGREE

HEALTH INFORMATION

CODING

Program Code: 1A31211

Because coding is at the heart of both health care reimbursement and clinical analysis, this extremely important aspect of health information management requires a highly trained and accurate professional. This Associate Degree Program prepares the individual to assign numerical codes to diagnoses, symptoms, and procedures using the current diagnostic coding and procedure classification systems which include, ICD 9-CM, ICD-10-CM and ICD 10-PCS and Current Procedural Terminology (CPT). Most third party payers, including the federal government and private insurance companies, require submission of codes as part of the hospital and/or physician billing process. Diagnoses and procedures codes are needed for comparing and tracking diseases, clinical research, statistical reporting, market data and planning. In addition to a high school diploma or equivalent, on-the-job coding experience and a solid coding education are needed to take the certification examination offered by the American Health Information Management Association to become a Certified Coding Specialist. Individuals skilled in medical coding are employed as coders for hospitals, physicians' offices, quality improvement organizations, health maintenance organizations, ambulatory care facilities, skilled nursing facilities, consulting firms, medical billing firms, or insurance companies.

MINIMUM STANDARDS FOR ENROLLMENT 1. High school diploma or passing of the General Education Development (GED) test or high school proficiency tests. 2. Eligibility for ENGL 100 C.

ENROLLMENT PROCEDURES 1. Students may enroll in either the fall or spring or summer sessions 2. Submit application to College. Students are responsible for furnishing all documents, records, forms and transcripts indicating minimum standards to the Admissions and Records Office.

TO EARN AN ASSOCIATE DEGREE

To earn an Associate Degree students must complete: (1) All major course requirements with a minimum grade of "C"; (2) 25 units of General Education Graduation Requirements with a minimum grade of "C"; (3) cultural diversity and reading requirements with a minimum grade of "C"; (4) any elective courses to complete a minimum of 60 units; and (5) have a minimum GPA of 2.0. At least 50% of all major coursework must be completed at Cypress College.

TO EARN A CERTIFICATE **Program Code: 1C31195**

To earn a certificate, students must (1) document a minimum of an Associate Degree; and (2) complete all major course work with a minimum grade of "C." At least 50% of all major course work must be completed at Cypress College.

TRANSFER CURRICULUM:

Transferability of health information coursework is determined by the individual receiving college.

SUMMER SESSION 1		Units
CIS 111 C	Computer Information Systems	3
HS 145 C	Survey of Medical Terminology	3
SEMESTER 1		Units
HI 101 C	Health Information Science	3
BIOL 210 C	Anatomy and Physiology	5
HI 102 C	Legal Aspects of Health Care	2
HI 100 C	Trends in Health Care Delivery	2
SEMESTER 2		Units
HS 147 C	Survey of Disease	3
HI 204 C	Beginning Coding	3
HI 245 C	Coding Skills Lab	1
HI 103 C	Health Care Statistics	3
SEMESTER 3		Units
HI 214 C	CPT/Ambulatory Care Coding	3
HI 245 C	Coding Skills Lab	1
HI 225 C	Information Technology	3
HI 105 C	Directed Practice I	4
SEMESTER 4		Units
HI 205 C	Directed Practice II	4
HI 220 C	Advanced Coding	3
HI 203 C	Medical Quality Management	2
HI 245 C	Coding Skills Lab	1
HI 110 C	Medical Insurance Billing	3
Total Units		52

HEALTH CARE SERVICES CLERK**CERTIFICATE** **Program Code: 1K07839**

Option of the Health Information Technology Program —
This program is no longer available for enrollment in the
current catalog year.

Option of the Health Information Technology Program. The Health Care Services Clerk option prepares the individual to perform entry-level clerical functions in health information/medical record departments, patient registration areas, and patient care units in health care facilities and physician offices. Students will demonstrate competency in processing admissions, assembling health records, analyzing health records, filing records, scanning documents, working with electronic health records and entering data into computers.

To earn a certificate, complete the required courses as listed with a minimum grade of "C." At least 50% of all course work must be completed at Cypress College.

Required Courses are listed in suggested sequence:		Units
CIS 111 C	Computer Information Systems	3
HS 145 C	Survey of Medical Terminology	3
HI 101 C	Health Information Science	3
HI 225 C	Information Technology	3
HI 299 C*	HI Tech Independent Study	2
Elective		Units
HI 102 C	Legal Aspects of Health Care	2
Total Units		16

*This course is a non-paid laboratory experience. Students are assigned to a hospital.

ASSOCIATE IN SCIENCE DEGREE**MEDICAL STAFF SERVICES**
MANAGEMENT**Program Code: 1S07836****CERTIFICATE IN MEDICAL STAFF SERVICES**
MANAGEMENT**Program Code: 1C21112**

Medical Staff Services Professionals are experts in provider credentialing and privileging, medical staff organization, accreditation and regulatory compliance, and provider relations in the diverse healthcare industry. They credential and monitor ongoing competence of the physicians and other practitioners who provide patient care services in the organization. They serve as professional administrative assistants coordinating activities of the organized medical staff and serving as liaison between the Medical Staff, Nursing Staff, and Hospital Administration within parameters established by the Chief Executive Officer of the Hospital. Medical Staff Services Professionals assist the medical staff in fulfilling its major responsibility to monitor the quality of patient care delivered by all members of the organized medical staff. This exciting position offers top management interfacing with boards of directors, medical staff leaders and hospital executive management. After three years work experience, one is eligible to write the examination offered by the National Association of Medical Staff Services to become a Certified Professional Medical Services Management. A second credential is for those who specialize in provider credentialing, the Certified Provider Credentialing Specialist (CPCS). Please visit <http://www.namss.org> for current eligibility requirements for the CPMSM and CPCS examinations.

MINIMUM STANDARDS FOR ENROLLMENT

High school graduation or passing of the General Education Development (GED) test or high school proficiency tests.

APPLICATION PROCEDURES

1. Students may enroll in either the fall, spring or summer sessions.
2. Apply online to Cypress College at <http://www.CypressCollege.edu>.
3. Students must furnish all documents and transcripts indicating minimum standards to the Admissions and Records office. Required Curriculum. Transferability of health information coursework is determined by the individual receiving college.

ASSOCIATE IN SCIENCE DEGREE

To earn an Associate Degree, students must complete (1) all major course requirements with a minimum of "C"; (2) 25 units of General Education Graduation requirements with a minimum grade of "C"; (3) the cultural diversity and reading requirements with a minimum grade of "C"; (4) any elective courses to complete a minimum of 60 units; and (5) have a minimum GPA of 2.0. At least 50% of all major course work must be completed at Cypress College.

ASSOCIATE CERTIFICATE

To earn a certificate, students must (1) document a minimum of an Associate Degree; and (2) complete all major course work with a minimum grade of "C." At least 50% of all major course work must be completed at Cypress College.

REQUIRED CURRICULUM

	SUMMER SESSION 1	Units
CIS 111 C	Computer Information Systems	3
	SEMESTER 1	Units
CIS 250 C	Word Processing	2
ENGL 100 C	College Writing	3
HI 100 C	Trends in Health Care Delivery	2
HS 145 C	Survey of Medical Terminology	3
	SEMESTER 2	Units
BIOL 210 C	Anatomy and Physiology	5
HI 101 C	Health Information Science	3
HI 102 C	Legal Aspects of Health Care	2
CIS 251 C	Advanced Word Processing	2
HS 277 C	Cultural Awareness and Health Care	3
	SEMESTER 3	Units
HS 147 C	Survey of Disease	3
HI 103 C	Health Care Statistics	3
MGT 111 C	Business Communications	3
HI 115 C	Medical Staff Services Science	3
	SEMESTER 4	Units
HI 215 C	Medical Staff Services Science	2
HI 225 C	Information Technology	3
HI 205 C	Directed Practice II	4
HI 203 C	Medical Quality Management	2
	Total Units	51

Health Information Technology (HI)

HI 080 C Selected Topics .5 to 8 Units

Term hours: Variable hours lecture and variable hours laboratory per week. This course is designed to meet the health information technology student's need for current topics and issues, updated information in health care review of specialized subject matter and/or preparation for health information related certification exams. Content will emphasize clinical application of theoretical principles in the discipline. Computer software, videotapes, resource materials, instructor assessment of individual student knowledge and skills will be utilized. Variable Unit Class. May be taken for credit 4 times. Pass/No Pass/Letter Grade Option.

HI 100 C Trends in Health Care Delivery 2 Units

Term hours: 32–36 lecture. This course investigates how and where health care is delivered in the United States and examines different health care practitioners and professional healthcare associations, the role of federal, state and local governments in health care, and the impact of managed care organizations. How consumers pay for health care as well as how health care providers receive reimbursement for services are discussed. The principles of customer focused health care are discussed. Current issues affecting the delivery of health care are emphasized. The course is recommended for students interested in health care or preparing for careers in health care. (CSU)

HI 101 C Health Information Science 3 Units

Term hours: 32–36 lecture and 48–54 laboratory. This course is an in-depth investigation of the generic components of the content, use and structure of health care data and data sets and how these components relate to primary and secondary health record systems. Emphasis will be placed on the content of the health record and documentation requirements pursuant to federal/state regulations and voluntary accrediting body standards. Discussions will focus on health care data sets. Laboratory activities will include data entry; assembly and analysis of medical records; filing and retrieval of information; and reading and interpreting medical records. \$3.00 Material Fee — Payable at Registration. (CSU)

HI 102 C Legal Aspects of Health Care 2 Units

Same as HS 102 C.
Term hours: 32–36 lecture. The focus of this course is on the legal and ethical issues affecting health care industry, health care providers, and health information managers. State laws, federal regulations, and case precedents form the basis for class discussion. Topics include tort law, confidentiality and release of medical information, informed consent, corporate and personal liability, patient rights, negligence and medical malpractice, contract and labor law, and ethics. Special emphasis is placed on the procedures for safeguarding the security of health care data to prevent inappropriate disclosure of confidential health information. (CSU)

HI 103 C Health Care Statistics 3 Units

Prerequisite: HI 101 C with a grade of "C" or better.
Term hours: 32–36 lecture and 48–54 laboratory. This course focuses on the effective collection, presentation, and verification of healthcare data necessary for the preparation of administrative and clinical reports. The role of data in clinical research, vital statistics and epidemiology will be discussed. Laboratory activities will focus on development of electronic data presentation skills and the interpretation and analysis of healthcare data. The role of the health information professional in transforming data into meaningful information for use in clinical and financial decision-making will be stressed. Data reliability and validity will be emphasized. (CSU)

HI 105 C Directed Practice I 4 Units

Prerequisite: HI 101 C and CIS 111 C and enrollment in the Health Information Technology Program.
Term hours: 32–36 lecture and 96–108 laboratory. This course is an investigation of the components of the content, use, and structure of health care data and data sets in the following alternative health care settings: long term care, home health, hospice, ambulatory care, behavioral health and rehab services. Emphasis is on analyzing the content of the health record and documentation requirements pursuant to federal/state regulations and voluntary accrediting body standards. Discussions will focus on the opportunities for health information management professionals in these different settings. Directed practice activities focus on the abstracting of data, analysis of findings, and preparation of reports in alternative health care settings. Students are assigned to an affiliated health related agency for supervised directed practice. Students shall have the status of learner and shall not be considered agency employees, nor shall they replace agency staff. Directed practice is conducted as a nonpaid, laboratory experience. (CSU)

HI 110 C Medical Insurance Billing 3 Units

Prerequisite: HS 145 C or equivalent.
Term hours: 48–54 lecture. This course focuses on the principles and mechanics of ambulatory care and medical office billing and will cover the entire billing process from the initial verification of insurance benefits, to the submission of the claim form, and to final collections process. It provides exposure to the many types of private and governmental insurance: Medicare, Medicaid, Blue Cross, health maintenance organizations, workers compensation, etc. CPT and ICD-9-CM coding principles related to claims submissions will focus on the use of complete diagnostic coding, CPT modifiers and HCPCS Level II codes. The advantages of electronic claims submission will be discussed. Students will learn to complete insurance claim Form 1500, the universally accepted billing format for medical offices. (CSU)

HI 115 C Medical Staff Services Science 3 Units

Term hours: 48–54 lecture. This comprehensive introductory course in fundamental concepts, principles and organization of the hospital and the medical staff services department includes the purpose and role of an organized medical staff; initial staff appointment; reappointment; privilege delineation; preparing agendas and writing minutes; monitoring and documenting proctoring, peer review, and quality review. A primary focus of the course is the guidelines for credentialing of physicians and allied health professionals in not only the hospital but also managed care settings. The organization of health care facilities and interdepartmental relationships are discussed. Emphasis will be placed on standards of voluntary accrediting agencies and regulations of federal and state licensing agencies. This course will provide useful information to the individual responsible for credentialing in a managed care organization and is good preparation for the CPMSM and CPCS credentialing exams. (CSU)

HI 203 C Medical Quality Management 2 Units

Same as HS 203 C.

Prerequisite: HS 145 C or background in medical terminology.

Term hours: 32–36 lecture. This course is an introduction to the principles of the quality management and performance improvement process in health care and provides a framework for gaining skills in collecting, analyzing and presenting data. Course content includes an introduction to quality management techniques and tools, patient safety, hospital and ambulatory accreditation requirements, utilization and risk management. Activities focus on the use of quality improvement tools to collect and present quality management data. (CSU)

HI 204 C Beginning Coding 3 Units

Prerequisite: HS 101 C, HS 145 C, and BIOL 210 C with minimum grades of "C."

Term hours: 32–36 lecture and 48–54 laboratory. Principles of nomenclature and classification systems emphasized include ICD-9-CM, ICD 10-CM and ICD 10-PCS. The focus is on coding and abstracting diagnostic and procedural data needed for clinical and administrative decision making, financial reimbursement and research. (CSU)

HI 205 C Directed Practice II 4 Units

Prerequisite: HI 103 C and HI 204 C and counselor approval indicating eligibility to graduate from Health Information Technology Program at the end of the semester.

Term hours: 32–36 lecture and 96–108 laboratory. This course will focus on the principles of organization of a health information management department; supervision of human resources in order to develop effective skills in leadership, motivation and team-building techniques; project management and marketing health information management services. Discussions focus on directed practice activities which emphasize the collection, analysis and presentation of health care data; quality improvement functions; and coding and abstracting. During the final semester, students are assigned to an affiliated health-related agency for supervised directed practice. Students shall have the status of learner and shall not be considered agency employees, nor shall they replace agency staff. Directed practice is conducted as a nonpaid, laboratory experience. (CSU)

HI 214 C CPT/Ambulatory Care Coding 3 Units

Prerequisite: HI 204 C or employed as a Health Information Coder.

Term hours: 32–36 lecture and 48–54 laboratory. This course focuses on the principles and mechanics of coding procedures according to Current Procedural Terminology and its relationship to the Health Care Common Procedure Coding System (HCPCS). The course will address the requirements for diagnostic and procedure coding in ambulatory care including hospital outpatient, outpatient surgery and physician office as well as the relationship to outpatient reimbursement methodologies. In the laboratory, students will solve coding problems using operative reports and encoding software. (CSU)

HI 215 C Medical Staff Services Science 2 Units

Prerequisite: HI 115 C.

Term hours: 32–36 lecture. Lecture and discussion focuses on selected aspects of medical staff services departmental management and supervision; due process and peer review hearings; and documentation of Medical Executive Committee activities. Throughout the course, there will be advanced review of office management systems. (CSU)

HI 220 C Advanced ICD-9-CM Coding — Lecture 3 Units

Prerequisite: HI 204 C and HS 147 C.

Term hours: 32–36 lecture and 48–54 laboratory. Advanced concepts in ICD-9-CM/ICD-10CM and ICD-10-PCS and its application in the prospective payment system are discussed. Lecture will focus on the structure of the Medicare-Severity diagnostic related groups; interpretation of laboratory and radiologic findings; basic pharmacology; and Coding Clinic guidelines. Laboratory activities will include coding actual medical records related to the most common diagnostic related groups using automated encoders. \$3.00 Materials Fee — Payable at Registration. (CSU)

HI 225 C Information Technology 3 Units

Prerequisite: CIS 111 C.

Term hours: 48–54 lecture. This course is an introduction to health informatics and information management technology. Emphasis is on electronic health records, personal health records, telemedicine, telecommunications, image-based document management systems, and HIPAA privacy and security standards. Activities center on using electronic health records software. (CSU)

HI 245 C Coding Skills Lab 1 to 2 Units

Prerequisite: Completion of or concurrent enrollment in HI 204 C.

Term hours: 48–108 laboratory depending on units attempted. The focus of this course is one of assisting the students in the development of coding skills and the application of those skills to different types of medical records. Students will code inpatient, emergency department, outpatient surgery, and referred outpatient medical records using ICD 9-CM, ICD 10-CM, ICD 10-PCS, and the Healthcare Common Procedure Coding System (HCPCS). The process of interpreting medical record information, choosing the required coding classification and assigning and sequencing codes correctly will be addressed. This course will provide an opportunity for students in the Health Information Technology and Health Information Coding Specialist Programs to demonstrate competencies required for completion of each program. Computer assisted instruction and automated encoders will be used within the course. This course may also be taken to update coding skills. May be taken for credit 4 times. Open Entry/Open Exit. Pass/No Pass. \$4.00 Material Fee — Payable at Registration. (CSU)

HI 299 C HI Tech Independent Study .5 to 2 Units

Prerequisite: Approved Independent Study Learning Contract.

Term hours: 8–36 lecture depending on units attempted. This course is designed for students enrolled in the Health Information Technology program or its options who wish to increase their knowledge and experience in applied areas. Students will participate in independent study in assigned areas under staff supervision. May be taken for credit 4 times. Pass/No Pass/Letter Grade Option. (CSU)

Health Science

Division of Health Science

Division Dean — John Sciacca

Counselors

Kelly Carter

Denise Vo

Health Science (HS)

HS 030 C Calculations for Medications 1 Unit

Advisory: Students should consider this course if they are eligible for admission to the nursing program or psychiatric technician program and/or have had challenges on the math section of the entrance exam, or are in need of updating of math/medication computation skills. MATH 010 C.
Term hours: 16–18 lecture. This course covers basic math skills, measurement systems and calculation methods involved in medication administration. Calculations with decimals, fractions, metric, apothecary, and household systems of measurement will be covered. Ratio and proportion will be used to calculate non-parenteral, parenteral and intravenous infusion dosages/rates. The course will include individual and group experiences with use of a workbook, computer software tutorials, and online resources. Non-Degree Credit. May be taken for credit 2 times. Pass/No Pass/Letter Grade Option.

HS 050 C Preparation for Health Science 3 Units

Term hours: 48–54 lecture. This course is designed for students interested in a health science career. The communication, reading and mathematical skills of students will be developed in relation to the various career needs. Remedial and introductory material necessary to enter and complete a Health Science Program are emphasized. Pass/No Pass/Letter Grade Option.

HS 060 C Selected Topics for NURS 192 C .5 to 2 Units

Prerequisite: Acceptance in the Nursing Program.
Term hours: 8–32 lecture depending on units attempted. This course is designed to correlate with NURS 192 C Fundamentals of Nursing, which provides introductory knowledge of the fundamentals of nursing. The assigned topics covered correlate with textbook and module assignments and enhance learning in specific theoretical concepts and nursing techniques. Computer software, videotapes, resource materials, instructor assessment of individual student's nursing knowledge and skills and individualized instruction are utilized. Pass/No Pass/Letter Grade Option.

HS 061 C Selected Topics for NURS 196 C .5 to 2 Units

Prerequisite: Acceptance in the Nursing Program and completion of or concurrent enrollment in NURS 196 C.
Term hours: 8–36 lecture. This course is designed to correlate with NURS 196 C Medical-Surgical Nursing I, providing increased knowledge of fundamentals of nursing and more complex nursing skills. The assigned topics covered correlate with the textbook and module assignments and enhance learning in specific theoretical concepts and more complex nursing techniques introduced in NURS 196 C. Films, videotapes, resource materials, instructor assessment of individual student's nursing knowledge and skills in individualized instruction are utilized. Pass/No Pass/Letter Grade Option. (CSU)

HS 062 C Selected Topics for NURS 292 C .5 to 2 Units

Prerequisite: Acceptance in the Nursing Program.
Term hours: 8–36 lecture. This course is designed to correlate with NURS 292 C Medical-Surgical Nursing II, providing an expansion of knowledge of medical/surgical nursing. The assigned topics covered correlate with the textbook and module assignments and aid in providing enhanced learning in specific theoretical concepts and nursing techniques introduced in NURS 292 C. Films, videotapes, resource materials, instructor assessment of individual student's nursing knowledge and skills in individualized instruction are utilized. Pass/No Pass/Letter Grade Option.

HS 063 C Selected Topics for NURS 197 C .5 to 2 Units

Prerequisite: Acceptance in the Nursing Program.
Term hours: 8–36 lecture. This course is designed to correlate with NURS 197 C Maternal/Newborn Nursing, providing an expansion of knowledge of maternal health care needs. The assigned topics covered correlate with the textbook and module assignments and enhance learning in specific theoretical concepts and nursing techniques introduced to NURS 197 C. Films, videotapes, resource materials, instructor assessment of individual student's nursing knowledge and skills in individualized instruction are utilized. Pass/No Pass/Letter Grade Option.

HS 064 C Selected Topics for NURS 293 C .5 to 2 Units

Prerequisite: Acceptance in the Nursing Program.
Term hours: 8–36 lecture. This is designed to correlate with NURS 293 C Mental Health Nursing, providing increased knowledge of mental health nursing. The assigned topics covered correlate with the textbook and module assignments and enhance learning in specific theoretical concepts and more complex nursing techniques introduced in NURS 293 C. Films, videotapes, resource materials, instructor assessment of individual student's nursing knowledge and skills in individualized instruction are utilized, as well as group discussion and dialogue. Pass/No Pass/Letter Grade Option.

HS 065 C Selected Topics for NURS 296 C .5 to 2 Units

Prerequisite: Acceptance in the Nursing Program.
Term hours: 8–32 lecture. This is designed to correlate with NURS 296 C Child/Family Nursing. The assigned topics correlate with theory, providing enrichment activities enabling the student to better understand pediatric nursing. The course utilizes audiovisual materials, selected references, computer simulated learning, and group discussions. Pass/No Pass/Letter Grade Option.

HS 066 C Selected Topics for NURS 297 C .5 to 2 Units

Prerequisite: Acceptance in the Nursing Program.
Term hours: 8–36 lecture. This course is designed to correlate with NURS 297 C Medical-Surgical Nursing III. Assigned topics covered correlate with textbook and module assignments in NURS 297 C. Clinical simulations are provided to permit the student practice in the performance of nursing procedures, as well as an opportunity for clinical competency testing. Videos, films, slides, games, resource materials, computer simulations, instructor assessment of student's nursing knowledge and skills, and individualized instruction are utilized. Pass/No Pass/Letter Grade Option.

HS 067 C Special Topics — Leadership .5 to 2 Units

Prerequisite: Acceptance in the Nursing Program.
Term hours: Lecture hours vary according to credit given. This course is designed to correlate with NURS 247 C. Depth of understanding of issues related to nursing practice and leadership are increased through the directed use of appropriate audio visual materials and selected references, as well as group discussions and dialogue. Pass/No Pass/Letter Grade Option.

HS 068 C Selected Topics — Gerontology .5 to 2 Units*Prerequisite: Enrollment in NURS 193 C or NURS 294 C.*

Term hours: 8–36 lecture. This course will focus on the special nursing and health care needs of the older adult and development of nursing skills necessary to meet those needs. Activities will focus on assisting the student in the further development of assessment skills, interpersonal and communication skills and patient teaching, which are essential in the care of the older adult. This course is an elective for students who desire enrichment in theories related to the care of the older adult. May be taken for credit 2 times. Pass/No Pass/Letter Grade Option.

HS 070 C Health Care Communication .5 to 1 Units*Advisory: ESL 184 C.*

Term hours: 24–54 laboratory. This course is designed for the non-native speaker to help enhance written and oral communication with clients and providers. Group as well as individualized instruction that correlate with the co-enrolled health care course of study will be taught. This course is open to students enrolled in any Health Science course or waiting to be re-admitted to a Health Science program. Non-Degree Credit. May be taken for credit 4 times. Open Entry/Open Exit. Pass/No Pass.

HS 076 C CPR for Health Care Providers 1 Unit

Term hours: 16–18 lecture. Basic life support “C” certification is required for health care providers. This class prepares the student with knowledge and skills required to perform adult one-rescuer CPR, adult two-rescuer CPR, pediatric one-rescuer CPR, child two-rescuer CPR, adult foreign body airway management and pediatric foreign body airway management. (The American Heart Association charges a fee for the “C” certification card). May be taken for credit 2 times. Pass/No Pass/Letter Grade Option.

HS 077 C CPR Recertification .5 Units*Prerequisite: Course in Basic Life Support with “C” Certification.*

Term hours: 8–9 lecture. Current BLS “C” certification is required for health care workers when providing direct patient care. This class prepares the student with current knowledge and skills required to obtain a recertification card from the American Heart Association. (The American Heart Association charges a fee for the recertification card). May be taken for credit 4 times. Pass/No Pass/Letter Grade Option.

HS 080 C Selected Topics in Nursing and Allied Health .5 to 8 Units

Term hours: 8–144 lecture depending on units attempted. This course is designed to meet the nursing and allied health science student need for current topics and issues, updated information in health care review of specialized subject matter, and/or preparation for health related licensure and certification exams. Content will emphasize clinical application of theoretical principles in the discipline. Computer software, videotapes, resource materials, instructor assessment of individual student knowledge and skills will be utilized. May be taken for credit 10 times. Pass/No Pass/Letter Grade Option.

HS 098 C Health Science Seminar .5 to 12 Units*Prerequisite: May be required.**Corequisite: May be required.**Advisory: May be required.*

Term hours: 0–216 lecture and/or 0–648 laboratory depending on units attempted. This class will utilize a lecture discussion approach to various topics within the Health Science programs. A variety of classes will be offered to introduce students to new experiences, update content on current issues, and explore new trends in health care. Fees may be required — Payable at Registration. May be taken for credit 1–4 times. Pass/No Pass or Pass/No Pass/Letter Grade Option or Standard Letter Grade.

HS 099 C Health Science Independent Study .5 to 2 Units*Prerequisite: Approved Independent Study Learning Contract.*

Term hours: Lecture hours vary according to credit given. This course is designed for students interested in health science programs who wish to increase their knowledge and experience in applied areas. Students will participate in independent study on assigned areas under staff supervision. May be taken for credit 4 times. Pass/No Pass/Letter Grade Option.

HS 145 C Survey of Medical Terminology 3 Units

Term hours: 48–54 lecture. This course includes fundamentals of word analysis, roots, prefixes and suffixes in an orientation to the body as a whole. A survey of medical terminology of the following body systems includes: skin and breast, musculoskeletal, neurological/psychiatric, cardiovascular, respiratory, digestive, genitourinary, prenatal, maternal, endocrine, and special senses. Anatomical and physiologic terminology, combining forms, diagnostic terms, clinical and surgical procedures, laboratory tests and abbreviations are included. A basic requirement for most career opportunities in the allied health occupations and in the court systems is the comprehension of medical terminology. (CSU)

HS 147 C Survey of Disease 3 Units*Prerequisite: HS 145 C and BIOL 210 C or BIOL 231 C or BIOL 241 C with minimum grades of “C.”*

Term hours: 48–54 lecture. This course is a comprehensive survey of pathophysiology focusing on how diseases affect human body function along with diagnostic and therapeutic interventions. It includes chronic and degenerative diseases; cardiac, respiratory, hematologic, musculoskeletal, gastrointestinal, genitourinary and reproductive system disorders; genetic disorders; infectious diseases; neoplasia; and fluid, electrolyte and acid-base imbalance disorders. (CSU)

HS 161 C Dying/Death and Grief/Mourning 3 Units

Same as HSCE 161 C.

Term hours: 48–54 lecture. This course is designed to assist individuals in such areas as personal death anxiety and working/living with the terminally ill person. Discussion includes special concerns such as how to handle grief, suicide, hospice, and other related topics. (CSU)

HS 165 C Ethical and Legal Issues 1.5 Units

Term hours: 24–27 lecture. This course will focus on making ethical choices in health care. An introduction to legal terminology, concepts, and principles will be presented. Topics include misconduct, malpractice, legal and professional standards and the scope of practice. The importance of proper documentation and informed consent is emphasized. The student will examine a variety of ethical issues and dilemmas found in clinical practice. The rights and responsibilities of patients and health care professionals will be examined. (CSU)

HS 168 C Patient Care Skills — Open Lab .5 to 3 Units*Prerequisite: Current first year Health Science program student or approved re-entry students needing remedial assistance or current professional license related to a health science program.*

Term hours: 24–162 laboratory TBA depending on units attempted. This open-entry, open-exit course with flexible hours and variable units allows self-paced individualized instruction and/or practice in basic client care skills with Health Science faculty supervision. The course provides students with space and equipment needed to learn client care skills. Health Science program students will complete a self-assessed learning plan prior to beginning their practice sessions. \$15.00 Material Fee — Payable at Registration. May be taken for credit 4 times. Open Entry/Open Exit. Pass/No Pass only. (CSU)

HS 268 C Patient Care Skills — Open Lab .5 to 3 Units

Prerequisite: Current second year Health Science program student or re-entry students needing remedial assistance or health care professional seeking an environment to practice advanced health science skills.

Advisory: BIOL 241 C, BIOL 220 C, BIOL 231 C and ENGL 100 C.

Term hours: 24–162 laboratory depending on units attempted. This open-entry, open exit course with flexible hours and variable units allows self-paced individualized instruction and/or practice in advanced client care skills with Health Science faculty supervision. The course provides students with space and equipment needed to learn advanced client care skills. Health Science program students will complete a self-assessed learning plan prior to beginning their practice sessions. May be taken for credit 4 times. Open Entry/Open Exit. Pass/No Pass only. \$15.00 Material Fee — Payable at Registration.

HS 277 C Cultural Awareness and the Health Care System 3 Units

Term hours: 48–54 lecture. This course is designed to examine how cultural differences impact health care and health care delivery. The influence of multi-ethnic cultures on health care concepts, intervention, and the delivery of health care will be discussed. The course will emphasize communication, beliefs and customs, cultural rituals, ethical and legal implications and staff relations in our multi-ethnic health care system. The content focuses on expanding sensitivity to cultural diversity in health care and includes medical, social, and legal issues. (CSU, AA GE, CSU GE, CUL DIV)

Health Science — Continuing Education

Division of Health Science

Division Dean — John Sciacca

Faculty

Health Science Instructors

Counselors

Kelly Carter

Denise Vo

Provider approved by the California Board of Registered Nursing — Provider Number 00110, for the number of contact hours the class meets. Request list of approved classes from the Health Science Division.

Health Science — Continuing Education (HSCE)

HSCE 161 C Dying/Death and Grief/Mourning 3 Units

Same as HS 161 C.

Term hours: 48–54 lecture/discussion. This course is designed to assist individuals in such areas as personal death anxiety and working/living with the terminally ill person. Discussion includes special concerns such as how to handle grief, suicide, hospice, and other related topics. (CSU)

HSCE 264 C Vascular Sonography Technology 3 Units

Same as RADT 264 C.

Prerequisite: A.R.D.M.S. (American Registry of Diagnostic Medical Sonographers) Registered Medical Sonographer and/or knowledge of basic ultrasound equipment and scanning techniques.

Term hours: 48–54 lecture. This course is the physical principles of vascular ultrasound technology. The course will focus toward learning the hemodynamic principles of normal and pathological vascular ultrasound procedures. Concepts of color and pulsed wave Doppler sonography as they apply to vascular imaging will be discussed. Emphasis on vascular anatomy, physiology and pathology to include vascular scanning protocol. Basic ultrasound physics and instrumentation will be reviewed. A working knowledge of basic ultrasound equipment, scanning techniques, and familiarity with color Doppler sonography is recommended. This course will prepare the student for the Registered Vascular Technology (RVT) examination. (CSU)

HSCE 266 C Princ. of Breast Ultrasound 3 Units

Same as RADT 266 C.

Prerequisite: American Registry of Diagnostic Medical Sonography license and/or knowledge of basic ultrasound equipment and scanning techniques.

Term hours: 48–54 lecture. This course will provide instruction for learning the normal and pathological appearance of breasts using ultrasound to include images that relate to mammography and MRI. Included in this course is the physiology of benign and malignant breast tumors and diagnostic procedures. The content will follow the ARDMS guidelines toward the goal of preparing the student to pass the ultrasound registry breast exam. (CSU)

History

Division of Social Sciences

Division Dean — Nina DeMarkey

Faculty

Carol Elsensohn Lewis

Michael Flores

David Halahmy

Bryan Seiling

Counselors

Velia Lawson

Therese Mosqueda-Ponce

Daniel Pelletier

PROGRAM LEARNING OUTCOMES (PLOs)

The courses taught by this department contribute to the General Education and Basic Skills Program Learning Outcomes. Please refer to General Education and Basic Skills Program Learning Outcomes.

ASSOCIATE IN ARTS DEGREE IN HISTORY FOR TRANSFER

This curriculum is designed to provide an opportunity for the History major to achieve an Associate in Arts Degree in History for Transfer (AA-T in History) which completes the first and second year requirements for transfer to a four-year public California institution. While at least a baccalaureate degree is recommended preparation for those considering professional careers, completion of this curriculum will demonstrate commitment to the field and provide comprehensive preparation for further academic study through upper-division course work. This curriculum specifically prepares the prospective transfer student for upper division coursework in History or a similar major at a California State University (CSU) campus. Students should consult a counselor, the Transfer Center and the catalog of the transfer college or university to plan a specific program of study to meet the college or university's requirements. Note: Courses that fulfill major requirements for an Associate Degree for Transfer at Cypress College might not be the same as those required for completing the major at all transfer institutions offering a Baccalaureate Degree. The Student Transfer Achievement Reform Act (Senate Bill 1440, now codified in California Education Code sections 66746–66749) guarantees admission to a California State University (CSU) campus for any community college student who completes an “associate degree for transfer,” a newly established variation of the associate degrees traditionally offered at a California community college. The AA-T is intended for students who plan to complete a bachelor's degree in a similar major at a CSU campus. Students completing these degrees (AA-T) are guaranteed admission to the CSU system, but not to a particular campus or major. Students transferring to a CSU campus that does accept the AA-T will be required to complete no more than 60 units after transfer to earn a bachelor's degree (unless the major is designated “high-unit” major). This degree may not be the best option for students intending to transfer to a particular CSU campus or to a university or college that is not part of the CSU system. Students should consult with a counselor when planning to complete the degree for more information on university admission and transfer requirements. History is the study of change over time. Historians analyze cause and effect, construct narratives from primary sources, and try to explain the actions of people in the past. Students in history courses learn more than dates, names, and events. They also learn how to interpret, debate, and draw conclusions. History majors acquire a broad perspective on the human experience and appreciate how the past has shaped the present. While a baccalaureate degree is still recommended, completion of this degree is excellent general preparation for careers in education, law, historical research, historical preservation, government, journalism, media, and communication. To earn an AA-T in History students must complete the following requirements: (1) a minimum of 18 semester units or 27 quarter units in the History major with a minimum grade of “C”; (2) California State University General Education Breadth requirements (CSU GE Breadth) or the Intersegmental General Education Transfer Curriculum (IGETC); (3) elective courses to complete a minimum of 60 units of CSU transferable coursework; (4) have an overall GPA of 2.0.

Required Core: 6 units		Units
HIST 170 C	History of the U.S. I or	3
HIST 170HC	Honors History of the U.S. I and	(3)
HIST 171 C	History of the U.S. II or	3
HIST 171HC	Honors History of the U.S. II	(3)
List A: 6 units chosen. Students will need to take either HIST 110 C/110HC or HIST 112 C/112HC and HIST 111 C/111HC or HIST 113 C/113HC.		Units
HIST 110 C	Western Civilizations I or	3
HIST 110HC	Honors Western Civilizations I or	(3)
HIST 112 C	World Civilizations I or	(3)
HIST 112HC	Honors World Civilizations I and	(3)
HIST 111 C	Western Civilizations II or	3
HIST 111HC	Honors Western Civilizations II or	(3)
HIST 113 C	World Civilizations II or	(3)
HIST 113HC	Honors World Civilizations II	(3)
List B Group 1: Select 3 units from the following: Any History course not pertaining to the U.S. or Europe. (History 112 C/112H C and 113 C/113H C may be taken if not used in List A)		Units
HIST 112 C	World Civilizations I	3
HIST 112HC	Honors World Civilizations I	3
HIST 113 C	World Civilizations II	3
HIST 113HC	Honors World Civilizations II	3
HIST 142 C	History of Latin America I	3
HIST 143 C	History of Latin America II	3
HIST 160 C	Asian Civilizations I	3
HIST 161 C	Asian Civilizations II	3
HIST 165 C	Middle Eastern History	3
HIST 135 C	African History	3
List B Group 2: 3 units: Any history course (may be taken if not used from List A or from List B Group 1)		Units
HIST 110 C	Western Civilizations I	3
HIST 110HC	Honors Western Civilizations I	3
HIST 111 C	Western Civilizations II	3
HIST 111HC	Honors Western Civilizations II	3
HIST 112 C	World Civilizations I	3
HIST 112HC	Honors World Civilizations I	3
HIST 113 C	World Civilizations II	3
HIST 113HC	Honors World Civilizations II	3
HIST 135 C	African History	3
HIST 142 C	History of Latin America I	3
HIST 143 C	History of Latin America II	3
HIST 151 C	Survey of British History I	3
HIST 152 C	Survey of British History II	3
HIST 160 C	Asian Civilizations I	3
HIST 161 C	Asian Civilizations II	3
HIST 162AC	History of the Americas I	3
HIST 162BC	History of the Americas II	3
HIST 163 C	History of Mexico	3
HIST 165 C	Middle Eastern History	3
HIST 270 C	Women in United States History	3
HIST 275 C	History of California	3
Total Units		18

History (HIST)

HIST 110 C Western Civilizations I 3 Units

Advisory: Eligibility for ENGL 100 C.

Term hours: 48–54 lecture. This course is a comprehensive study of the contributions of previous civilizations from prehistoric times to the beginning of the modern era. The development of the present day Western mind and institutions is traced by analyzing the beliefs, myths, accomplishments and problems of the civilizations of Mesopotamia, Egypt, Greece, Rome, the Medieval Period, Renaissance and Reformation. Duplicate credit not granted for HIST 110HC. (UC Credit Limitation/CSU, AA GE, CSU GE, IGETC)

HIST 110HC Honors Western Civilizations I 3 Units

Advisory: Eligibility for ENGL 100 C.

Term hours: 48–54 lecture. This course is an enhanced comprehensive study of the contributions of previous civilizations from prehistoric times to the beginning of the modern era. The development of the present day Western mind and institutions is traced by analyzing the beliefs, myths, accomplishments and problems of the civilizations of Mesopotamia, Egypt, Greece, Rome, the Medieval Period, Renaissance and Reformation. Duplicate credit not granted for HIST 110 C. (UC Credit Limitation/CSU, AA GE, CSU GE, IGETC)

HIST 111 C Western Civilizations II 3 Units

Advisory: Eligibility for ENGL 100 C.

Term hours: 48–54 lecture. This course covers the development of Western civilization from the beginning of the modern era to the present day. A major part of this course deals with the last 100 years. It covers imperialism, communism, industrialism and nationalism with related political-social, and cultural issues. Duplicate credit not granted for HIST 111HC. (UC Credit Limitation/CSU, AA GE, CSU GE, IGETC)

HIST 111HC Honors Western Civilizations II 3 Units

Advisory: Eligibility for ENGL 100 C.

Term hours: 48–54 lecture. This course is an enhanced comprehensive study of the development of Western civilization from the beginning of the modern era to the present day. A major part of this course deals with the last 100 years. It covers imperialism, communism, industrialism and nationalism with related political, social, and cultural issues. Duplicate credit not granted for HIST 111 C. (UC Credit Limitation/CSU, AA GE, IGETC)

HIST 112 C World Civilizations I 3 Units

Advisory: Eligibility for ENGL 100 C.

Term hours: 48–54 lecture. This course is a survey of the roots and development of civilizations in Africa, the Americas, Asia, and Europe from the earliest times to 1550 CE. Duplicate credit not granted for HIST 112HC. (UC Credit Limitation/CSU, AA GE, CSU GE, IGETC)

HIST 112HC Honors World Civilizations I 3 Units

Advisory: Eligibility for ENGL 100 C.

Term hours: 48–54 lecture. This course is an enhanced survey of the roots and development of the various civilizations in Africa, the Americas, Asia, and Europe from the earliest times to 1550 CE. Duplicate credit not granted for HIST 112 C. (UC Credit Limitation/CSU, AA GE, CSU GE, IGETC)

HIST 113 C World Civilizations II 3 Units

Advisory: Eligibility for ENGL 100 C.

Term hours: 48–54 lecture. This course is a survey of the roots and development of civilizations in Africa, the Americas, Asia, and Europe from 1550 CE to the present. Duplicate credit not granted for HIST 113HC. (UC Credit Limitation/CSU, AA GE, CSU GE, IGETC)

HIST 113HC Honors World Civilizations II 3 Units

Advisory: Eligibility for ENGL 100 C.

Term hours: 48–54 lecture. This course is an enhanced survey of the roots and development of civilizations in Africa, the Americas, Asia, and Europe from 1550 CE to the present. Duplicate credit not granted for HIST 113 C. (UC Credit Limitation/CSU, AA GE, CSU GE, IGETC)

HIST 135 C African History 3 Units

Advisory: Eligibility for ENGL 100 C.

Term hours: 48–54 lecture. This course is a survey of African history from the earliest beginnings to contemporary times. A special emphasis is placed on the various cultures of Africa, demography and general chronology of the rise and fall of nation states, and the impact of Western culture through the colonial, neo-colonial, and contemporary periods. (UC/CSU, AA GE, CSU GE, IGETC)

HIST 142 C History of Latin America I 3 Units

Advisory: Eligibility for ENGL 100 C.

Term hours: 48–54 lecture. This course is a survey of the history of Latin America from the late pre-Columbian era to the independence period. Emphasis is placed upon European conquest, the interaction of Europeans with Native American and African cultures, and the planting of colonial societies in the regions of Mexico, Central America, the Caribbean, and South America. Spanish, French, Portuguese, British, and Dutch America are compared as to their socio-cultural, economic, and political development during the colonial and independence periods. (UC/CSU, AA GE, CSU GE, IGETC)

HIST 143 C History of Latin America II 3 Units

Advisory: Eligibility for ENGL 100 C.

Term hours: 48–54 lecture. This course is a survey of the history of Latin America from the independence period to the present. Emphasis is placed upon: the nation-building process, integration into the world capitalist system, the inequality between the elite classes and the masses, the development of new groups, such as the urban middle and working classes, the conflict between liberalism and the Catholic Church, race relations, challenges of political regimes, relationships during the Cold War, and the new global economic models. (UC/CSU, AA GE, CSU GE, IGETC)

HIST 151 C Survey of British History I 3 Units

Advisory: Eligibility for ENGL 100 C.

Term hours: 48–54 lecture. This course is a survey of English history and civilizations from prehistoric times to the end of the Stuart period. The course concentrates on the development of governmental institutions, and the cultural and intellectual foundations of England and its people. (UC/CSU, CSU GE, IGETC)

HIST 152 C Survey of British History II 3 Units

Advisory: Eligibility for ENGL 100 C.

Term hours: 48–54 lecture. This course is the continuing survey of the development of the United Kingdom from 1715 to the present. Special emphasis in this course will be placed on England's political and cultural expansion around the globe. (UC/CSU, CSU GE, IGETC)

HIST 160 C Asian Civilizations I 3 Units

Advisory: Eligibility for ENGL 100 C.

Term hours: 48–54 lecture. This course is a comparative history of the civilizations of Asia from their birth to the 19th century. It explores the social, cultural, political, and economic developments of East, South, and Southeast Asian countries. Pass/No Pass/Letter Grade Option. (UC/CSU, AA GE, CSU GE, IGETC)

HIST 161 C Asian Civilizations II 3 Units*Advisory: Eligibility for ENGL 100 C.*

Term hours: 48–54 lecture. This course is a comparative history of the civilizations of Asia from the 19th century to the present. It explores the social, cultural, political, and economic developments of East, South, and Southeast Asian countries. Pass/No Pass/Letter Grade Option. (UC/CSU, AA GE, CSU GE, IGETC)

HIST 162AC History of the Americas I 3 Units*Advisory: Eligibility for ENGL 100 C.*

Term hours: 48–54 lecture. This course is a survey of the history of the Western hemisphere from its discovery to the wars of independence. Emphasis is placed upon European conquest, the interaction of Europeans with Native American and African cultures, and the planting of colonial societies in the New World. Spanish America, Brazil, Canada, and the United States are compared as to their socio-cultural, economic, and political development during the colonial and independence periods. (UC/CSU, AA GE, CSU GE, IGETC)

HIST 162BC History of the Americas II 3 Units*Advisory: Eligibility for ENGL 100 C.*

Term hours: 48–54 lecture. This course is a comparative study of the political, social, and economic development of the independent nations of the Western hemisphere from the wars of independence to the present. Emphasis is placed upon the present international relations of these nations. (UC/CSU, AA GE, CSU GE, IGETC)

HIST 163 C History of Mexico 3 Units*Advisory: Eligibility for ENGL 100 C.*

Term hours: 48–54 lecture. This course is a survey of the economic, socio-cultural and political history of Mexico from the pre-Columbian period to the present. (UC/CSU, AA GE, CSU GE, IGETC)

HIST 165 C Middle Eastern History 3 Units*Advisory: Eligibility for ENGL 100 C.*

Term hours: 48–54 lecture. This course covers the historical development of the Middle East from the rise of Middle Eastern civilization to the present, emphasizing the Islamic religion, art, philosophy, and key political and social conflicts of modern times. (UC/CSU, AA GE, CSU GE, IGETC)

HIST 170 C History of the United States I 3 Units*Advisory: Eligibility for ENGL 100 C.*

Term hours: 48–54 lecture. This course is a survey of American history from the colonial foundations to 1877. The course satisfies state requirements in American history and institutions for transfer. Duplicate credit not granted for HIST 170HC. (UC Credit Limitation/CSU, AA GE, CSU GE, IGETC)

HIST 170HC Honors History of the United States I 3 Units*Advisory: Eligibility for ENGL 100 C.*

Term hours: 48–54 lecture. This course is an enhanced survey of American history from the colonial foundations to 1877. This course satisfies state requirements in American history and institutions for transfer. Duplicate credit not granted for HIST 170 C. (UC Credit Limitation/CSU, AA GE, CSU GE, IGETC)

HIST 171 C History of the United States II 3 Units*Advisory: Eligibility for ENGL 100 C.*

Term hours: 48–54 lecture. This course is a survey of American history from 1877 to the present. This course satisfies state requirement in American history and institutions for transfer. Duplicate credit not granted for HIST 171HC. (UC Credit Limitation/CSU, AA GE, CSU GE, IGETC)

HIST 171HC Honors History of the United States II 3 Units*Advisory: Eligibility for ENGL 100 C.*

Term hours: 48–54 lecture. This course is an enhanced survey of American History from 1877 to the present. This course satisfies state requirements in American History and institutions for transfer. Duplicate credit will not be granted for HIST 171 C. (UC Credit Limitation/CSU, AA GE, CSU GE, IGETC)

HIST 270 C Women in United States History 3 Units*Advisory: Eligibility for ENGL 100 C.*

Term hours: 48–54 lecture. This course is a survey of the economic, social, intellectual and political history of women in America from colonial times to the present. Special emphasis is placed upon the feminist movements and the suffrage struggle of the 19th and 20th centuries. (UC/CSU, AA GE, CSU GE, IGETC)

HIST 275 C History of California 3 Units*Advisory: Eligibility for ENGL 100 C.*

Term hours: 48–54 lecture. This course surveys the economic, social, ethnic, intellectual, and political history of California from the earliest times to the present. Special emphasis is placed upon issues of diversity caused by demographic changes. (UC/CSU, CSU GE, IGETC, CUL DIV)

HIST 295 C Research Methods — Oral History 2 Units

Same as SOSC 295 C.

Term hours: 16–18 lecture and 48–54 laboratory. This course introduces the student to the special techniques of tape recorded interviews to document 20th century history. Areas of study will include interviewing techniques, historical editing, and transcripts of interviews. The course does not satisfy General Education requirements in Social Science. (CSU)

HIST 298 C History Seminar .5 to 12 Units*Prerequisite: May be required.**Corequisite: May be required.**Advisory: May be required.*

Term hours: 0–216 lecture and/or 0–648 laboratory. This is a lecture/discussion type course developed on a particular limited problem or topic of interest to students. It is designed for able students who wish to increase their knowledge of a particular topic concerning which no other regular class is offered. A paper or group activity may be requested. Credit may range from .5 units to 12 units. Consult class schedule for the offerings a particular semester. May be taken for credit 1–4 times. Pass/No Pass/or Pass/No Pass/Letter Grade Option or Standard Letter Grade. Fees may be required — Payable at Registration. (UC Credit Limitation/CSU)

HIST 299 C History Independent Study 1 Unit*Prerequisite: Approved Independent Study Learning Contract.*

May be taken for credit 3 times.

Varying hours of scheduled conferences per week according to instructor. Independent study is for able students who wish to extend their knowledge of a particular area through individual research and study. It is thought that topics might develop out of a curiosity stimulated in a regular class. The student would then contact the supervising instructor to develop a contract for his/her particular interest so that they could learn more regarding their special topic. (UC Credit Limitation/CSU)

HISTORY TRANSFER PROGRAM

Students should consult a counselor or www.assist.org for lower division major requirements for most California public universities. (See the Standard Definitions section of the catalog for a description of ASSIST.) Students transferring to an independent college/university should consult the catalog of the individual school and a counselor for lower division major requirements.

Hotel, Restaurant, Culinary Arts

Division of Career Technical Education

Division Dean — Steve Donley

Faculty

Lisa Clark
Jeremy Peters
Stephanie Rosati

Counselor

Jane Jepson

PROGRAM LEARNING OUTCOMES (PLOs)

Hotel, Restaurant and Culinary Arts

A Cypress College student who earns a Certificate from the Hotel, Restaurant, Culinary Arts program in Hotel Management, Foodservice Management or Culinary Arts will:

- Acquire the necessary skills for hospitality/culinary arts employment to include demonstrated ability in effective communications, customer service, teamwork, cost control, ethical considerations, critical thinking and leadership
- Demonstrate competencies required for hospitality/culinary employment to include sanitation and safety, nutrition, restaurant and hotel operations, and specialized culinary techniques
- Enhance his/her career and educational opportunities within the hospitality and culinary industry

ASSOCIATE IN SCIENCE DEGREE

CULINARY ARTS Program Code: 1S03813

The Culinary Arts program provides students with fundamentals in the methods of food safety, handling, preparation, and kitchen management. It includes exposure to various styles of cuisines, and proper use of culinary applications and equipment. The program is designed to help students develop a working knowledge of what is required to be successful in the fast pace culinary industry.

To earn an Associate Degree students must complete all graduation requirements to include: (1) all major course requirements with a “C” or better; (2) 25 units of General Education Graduation Requirements; (3) the cultural diversity and reading requirements; (4) any elective courses to complete a minimum of 60 units; and, (5) have a minimum GPA of 2.0. At least 50% of all major course work must be completed at Cypress College. Courses that fulfill major requirements for an Associate Degree at Cypress College might not be the same as those required for completing the major at a transfer institution offering a Baccalaureate Degree. For information on specific university requirements, please consult with your counselor, or visit the Transfer Center.

Required courses are listed in suggested sequence:		Units
HRC 100 C	Nutrition	3
HRC 101 C	Intro to Hospitality Careers	3
HRC 120 C	Sanitation and Safety	3
HRC 125 C	Restaurant/Banquet Operations	3
HRC 135 C	Culinary Fundamentals I	3
HRC 136 C	Baking Fundamentals I	3
HRC 231 C	Cost Control in Hospitality	3
HRC 145 C	The Art of Garde Manger	3
HRC 152 C	Menu Planning and Purchasing	3
HRC 235 C	Culinary Fundamentals II	3
HRC 255 C	American Regional Cuisine	3
HRC 265 C	International Cuisine	3
HRC 295 C	Hospitality Internship	3
Total Units		39

CULINARY ARTS CERTIFICATE

Program Code: 1C21119

The Culinary Arts program provides students with basic competencies in the methods of food handling, cooking, and culinary management. It includes exposure to various styles, and proper use of culinary applications and equipment. The program is designed to help students develop a working knowledge of what is required to be successful for fast track culinary management potential.

To earn a certificate, complete the required courses as listed with a minimum grade of “C.” At least 50% of all course work must be completed at Cypress College.

Required courses are listed in suggested sequence:		Units
HRC 100 C	Nutrition	3
HRC 101 C	Intro to Hospitality Careers	3
HRC 120 C	Sanitation and Safety	3
HRC 125 C	Restaurant/Banquet Operations	3
HRC 135 C	Culinary Fundamentals I	3
HRC 136 C	Baking Fundamentals I	3
HRC 145 C	The Art of Garde Manger	3
HRC 152 C	Menu Planning and Purchasing	3
HRC 231 C	Cost Control in Hospitality	3
HRC 235 C	Culinary Fundamentals II	3
HRC 255 C	American Regional Cuisine	3
HRC 265 C	International Cuisine	3
HRC 295 C	Hospitality Internship	3
Total Units		39

ASSOCIATE IN SCIENCE DEGREE BAKING AND PASTRY ARTS

Program Code: 1S31170

The Baking and Pastry Arts program provides students with a broad and thorough foundation in the art of pastry and baking, from bread to chocolate to ice cream, and everything in between. The program is designed to help students develop a working knowledge of what is required to be successful in the fast pace culinary industry. To earn an Associate Degree students must complete all graduation requirements to include: (1) all major course requirements with a “C” or better; (2) 25 units of General Education Graduation Requirements; (3) the cultural diversity and reading requirements; (4) any elective courses to complete a minimum of 60 units; and, (5) have a minimum GPA of 2.0. At least 50% of all major course work must be completed at Cypress College. Courses that fulfill major requirements for an Associate Degree at Cypress College might not be the same as those required for completing the major at a transfer institution offering a Baccalaureate Degree. For information on specific university requirements, please consult with your counselor, or visit the Transfer Center.

Required courses are listed in suggested sequence:		Units
HRC 100 C	Nutrition	3
HRC 101 C	Intro to Hospitality Careers	3
HRC 120 C	Sanitation and Safety	3
HRC 135 C	Culinary Fundamentals I	3
HRC 136 C	Baking Fundamentals I	3
HRC 152 C	Menu Planning and Purchasing	3
HRC 231 C	Cost Control in Hospitality	3
HRC 236 C	Baking Fundamentals II	3
HRC 246 C	Pastry Arts	3
HRC 295 C	Hospitality Internship	3
HRC 255 C	American Regional Cuisine	3
	or	
HRC 265 C	International Cuisine	(3)
Total Units		33

BAKING AND PASTRY ARTS CERTIFICATE **Program Code: 1C31127**

The Baking and Pastry Arts program provides students with a broad and thorough foundation in the art of pastry and baking, from bread to chocolate to ice cream, and everything in between. The program is designed to help students develop a working knowledge of what is required to be successful in the fast paced culinary industry.

Required courses are listed in suggested sequence:		Units
HRC 100 C	Nutrition	3
HRC 101 C	Intro to Hospitality Careers	3
HRC 120 C	Sanitation and Safety	3
HRC 135 C	Culinary Fundamentals I	3
HRC 136 C	Baking Fundamentals I	3
HRC 152 C	Menu Planning and Purchasing	3
HRC 231 C	Cost Control in Hospitality	3
HRC 236 C	Baking Fundamentals II	3
HRC 246 C	Pastry Arts	3
HRC 295 C	Hospitality Internship	3
HRC 255 C	American Regional Cuisine	3
	or	
HRC 265 C	International Cuisine	(3)
Total Units		33

BAKING FUNDAMENTALS CERTIFICATE **Program Code: 1K12968**

This two semester certificate program is designed to provide the student with fundamental knowledge and techniques of baking and pastry, food safety, an understanding of the complexity of kitchen operations and an appreciation of the hospitality industry.

Graduates will gain the knowledge and applied skills required to enter the hospitality industry as a baker or pastry cook.

To earn a certificate, complete the required courses as listed with a minimum grade of "C." At least 50% of all course work must be completed at Cypress College.

Required courses are listed in suggested sequence:		Units
HRC 101 C	Intro to Hospitality Careers	3
HRC 120 C	Sanitation and Safety	3
HRC 136 C	Baking Fundamentals I	3
HRC 236 C	Baking Fundamentals II	3
Total Units		12

CULINARY FUNDAMENTALS CERTIFICATE **Program Code: 1K12969**

This two semester certificate program is designed to provide the student with fundamental knowledge and techniques of food preparation, food safety, an understanding of the complexity of kitchen operations and an appreciation of the hospitality industry.

Graduates will gain the knowledge and applied skills required to enter the hospitality industry as a cook.

To earn a certificate, complete the required courses as listed with a minimum grade of "C." At least 50% of all course work must be completed at Cypress College.

Required courses are listed in suggested sequence:		Units
HRC 101 C	Intro to Hospitality Careers	3
HRC 120 C	Sanitation and Safety	3
HRC 135 C	Culinary Fundamentals I	3
HRC 235 C	Culinary Fundamentals II	3
Total Units		12

ASSOCIATE IN SCIENCE DEGREE FOOD SERVICE MANAGEMENT **Program Code: 1S07848**

The Associate of Science Degree in Food Service Management offers comprehensive coursework in restaurant management, hotel food and beverage operations, managed food services and catering. Coursework emphasizes cost control, guest service strategies, supervision best practices, legal aspects, culinary production, nutrition, and the importance of teamwork, effective communication skills, ethical considerations and critical thinking. Students will prepare for a career in the growing restaurant and food service industry and/or to transfer to a four year university.

To earn an Associate Degree students must complete: (1) all major course requirements with a "C" or better; (2) 25 units of General Education Graduation Requirements; (3) the cultural diversity and reading requirements; (4) any elective courses to complete a minimum of 60 units; and, (5) have a minimum GPA of 2.0. At least 50% of all major course work must be completed at Cypress College.

Courses that fulfill major requirements for an Associate Degree at Cypress College might not be the same as those required for completing the major at a transfer institution offering a Baccalaureate Degree. For information on specific university requirements, please consult with your counselor, or visit the Transfer Center.

Required courses are listed in suggested sequence:		Units
Course #	Title	
HRC 100 C	Nutrition	3
HRC 101 C	Intro to Hospitality Careers	3
HRC 120 C	Sanitation and Safety	3
HRC 125 C	Restaurant/Banquet Operations	3
HRC 135 C	Basic Cooking Techniques	3
HRC 164 C	Hospitality Law	3
HRC 152 C	Menu Planning and Purchasing	3
HRC 166 C	Managing Guest Relations	3
HRC 231 C	Cost Control in Hospitality	3
HRC 232 C	Catering and Event Management	3
HRC 295 C	Hospitality Internship	3
Total Units Required		33

**FOOD SERVICE MANAGEMENT
CERTIFICATE**

Program Code: 1C21120

The Food Service Management Certificate offers comprehensive coursework in restaurant management, hotel food and beverage operations, managed food services and catering. Coursework emphasizes cost control, guest services strategies, supervision best practices, legal aspects, culinary production, nutrition, and the importance of teamwork, effective communication skills, ethical considerations and critical thinking. Students will prepare for a career in the growing restaurant and food service industry.

To earn a certificate, students must complete the required courses as listed with a “C” or better. At least 50% of all course work must be completed at Cypress College.

Required courses are listed in suggested sequence:

Course #	Title	Units
HRC 100 C	Nutrition	3
HRC 101 C	Intro to Hospitality Careers	3
HRC 120 C	Sanitation and Safety	3
HRC 125 C	Restaurant/Banquet Operations	3
HRC 135 C	Basic Cooking Techniques	3
HRC 152 C	Menu Planning and Purchasing	3
HRC 164 C	Hospitality Law	3
HRC 166 C	Managing Guest Relations	3
HRC 231 C	Cost Control in Hospitality	3
HRC 232 C	Catering and Event Management	3
HRC 295 C	Hospitality Internship	3
Total Units Required		33

DINING ROOM OPERATIONS

CERTIFICATE

Program Code: 1K12979

This certificate provides students with the necessary skills and knowledge to gain entry level employment as a dining room server.

To earn a certificate, students must complete the required courses as listed with a minimum grade of “C.” At least 50% of all course work must be completed at Cypress College.

Course #	Title	Units
HRC 101 C	Intro to Hospitality Careers	3
HRC 120 C	Sanitation and Safety	3
HRC 125 C	Restaurant/Banquet Operations	3
HRC 166 C	Managing Guest Relations	3
Total Units Required		12

ASSOCIATE IN SCIENCE DEGREE

HOTEL MANAGEMENT

Program Code: 1S03763

The Associate of Science Degree in Hotel Management offers comprehensive coursework in rooms operations, revenue management, food and beverage, event management, human resources, marketing and support operations. Coursework emphasizes guest service strategies, leadership best practices, cost control, legal aspects, ethical considerations and the importance of effective communication skills, teamwork, and critical thinking. Students will prepare for a career in the dynamic hospitality industry and/or transfer to a four year university.

To earn an Associate Degree, students must complete all graduation requirements to include (1) all major course requirements with a “C” or better; (2) 25 units of General Education Graduation Requirements; (3) the cultural diversity and reading requirements; (4) any elective courses to complete a total of 60 units; and, (5) have a minimum GPA of 2.0. At least 50% of all major course work must be completed at Cypress College.

Courses that fulfill major requirements for an Associate Degree at Cypress College might not be the same as those required for completing the major at a transfer institution offering a Baccalaureate Degree. For information on specific university requirements, please consult with your counselor, or visit the Transfer Center.

Required courses are listed in suggested sequence:

Course #	Title	Units
HRC 101 C	Intro to Hospitality Careers	3
HRC 120 C	Sanitation and Safety	3
HRC 125 C	Restaurant/Banquet Operations	3
HRC 160 C	Rooms Division Operations	3
HRC 164 C	Hospitality Law	3
HRC 166 C	Managing Guest Relations	3
HRC 230 C	Hotel Management	3
HRC 231 C	Cost Control in Hospitality	3
HRC 232 C	Catering and Event Management	3
HRC 295 C	Hospitality Internship	3
ECON 105 C	Principles of Economics — Micro	3
MKT 222 C	Principles of Marketing	3
Total Units Required		36

HOTEL OPERATIONS

CERTIFICATE

Program Code: 1C21121

The Hotel Operations Certificate offers coursework in rooms operations, revenue management, food and beverage, event management, human resources, marketing, and support operations. Coursework emphasizes guest service strategies, effective communication skills, teamwork, leadership, cost control, ethics and critical thinking. Students will prepare for a career in the dynamic hotel industry.

To earn a certificate, students must complete the required courses as listed with a “C” or better. At least 50% of all course work must be completed at Cypress College.

Required courses are listed in suggested sequence:

Course #	Title	Units
HRC 101 C	Intro to Hospitality Careers	3
HRC 120 C	Sanitation and Safety	3
HRC 125 C	Restaurant/Banquet Operations	3
HRC 160 C	Rooms Division Operations	3
HRC 164 C	Hospitality Law	3
HRC 166 C	Managing Guest Relations	3
HRC 230 C	Hotel Management	3
HRC 231 C	Cost Control in Hospitality	3
HRC 232 C	Catering and Event Management	3
HRC 295 C	Hospitality Internship	3
ECON 105 C	Principles of Economics — Micro	3
MKT 222 C	Principles of Marketing	3
Total Units Required		36

RESTAURANT/LODGING ENTREPRENEUR

CERTIFICATE

Program Code: 1K12985

This certificate provides students with the necessary skills and knowledge to start, manage and promote their own restaurant, inn, or bed and breakfast establishment. Students who complete the program will learn about guest relations, customer service, basic management techniques, food handling and preparation, marketing and sales of their own small business.

To earn a certificate, students must complete the required courses as listed with a minimum grade of “C.” At least 50% of all course work must be completed at Cypress College.

Required courses are listed in suggested sequence:

Course #	Title	Units
HRC 121 C	Servsafe Food Safety	.5
HRC 135 C	Basic Cooking Techniques	3
HRC 160 C	Front Office Operations	3
HRC 166 C	Managing Guest Relations	3
MKT 208 C	Principles of Selling	3
	or	
MKT 222 C	Principles of Marketing	(3)
MGT 261 C	Small Business Management	3
Total Units Required		15.5

ROOMS OPERATIONS CERTIFICATE**(formerly Front Desk Operations)****Program Code: 1K12980**

The Rooms Operations Certificate offers coursework in hotel front office operations, housekeeping, maintenance, security, guest relations and leadership philosophy. Students will prepare for entry-level employment in a hotel rooms division.

To earn a certificate, students must complete the required courses as listed with a minimum grade of "C." At least 50% of all course work must be completed at Cypress College.

Required courses are listed in suggested sequence:

Course #	Title	Units
HRC 101 C	Intro to Hospitality Careers	3
HRC 166 C	Managing Guest Relations	3
HRC 160 C	Rooms Division Operations	3
HRC 230 C	Hotel Management	3
Total Units Required		12

SPECIAL EVENT MANAGEMENT CERTIFICATE**Program Code: 1K17140**

The Special Event Management field is a large part of the local economy. Students will learn skills and knowledge necessary for success in the special event management field. This skill certificate provides students with entry-level skills and knowledge to transition into this rapidly growing field.

To earn a certificate, students must complete the required courses as listed with a minimum grade of "C." At least 50% of all course work must be completed at Cypress College.

Required courses are listed in suggested sequence:

Course #	Title	Units
HRC 101 C	Intro to Hospitality Careers	3
HRC 125 C	Restaurant/Banquet Operations	3
HRC 232 C	Catering and Event Management	3
MKT 222 C	Principles of Marketing	3
MGT 261 C	Small Business Management	3
Total Units Required		15

HOSPITALITY, RESTAURANT, CULINARY ARTS TRANSFER PROGRAM

Students should consult a counselor or www.assist.org for lower division major requirements for most California public universities. (See the Standard Definitions section of the catalog for a description of ASSIST.) Students transferring to an independent college/university should consult the catalog of the individual school and a counselor for lower division major requirements.

Hotel, Restaurant, Culinary Arts (HRC)**HRC 100 C Nutrition****3 Units**

Term hours: 48–54 lecture. This course is a study of the interactions between food and a living organisms. Course includes the role of carbohydrates, fats, protein, vitamins, water, minerals, alcohol and drugs in nutritional status. Emphasis is on the practical application of nutritional information to the individual diet and the recognition of nutrition misinformation. (UC/CSU, AA GE, CSU GE)

HRC 101 C Introduction to Hospitality Careers**3 Units**

Prerequisite: Eligibility for ENGL 060 C or acceptable score on the placement test.

Term hours: 48–54 lecture. This course provides an overview of operations and career opportunities in the global hospitality and culinary arts industry, including lodging, restaurants, culinary arts, baking and pastry, managed services, cruise industry, gaming entertainment, private clubs, meeting, planning and special event management. Students will prepare a personalized career project. (CSU)

HRC 120 C Sanitation and Safety**3 Units**

Prerequisite: Eligibility for ENGL 060 C or acceptable score on placement test.

Term hours: 48–54 lecture. This course will acquaint students with sanitation and safety principles and prepare students for the national food handler's certification examination. Course content includes strategies to identify and prevent foodborne illness, the flow of food through food service operations and sanitation management. (CSU)

HRC 121 C ServSafe Food Safety**.5 Units**

Term hours: 8–9 lecture. A short course designed to acquaint industry employees with food safety and sanitation principles and prepare them to take the Food Safety Certification exam. A certified food handler is required in all California restaurant establishments. (CSU)

HRC 125 C Restaurant/Banquet Operations**3 Units**

Prerequisite: HRC 101 C and HRC 120 C with minimum grades of "C."

Term hours: 32–36 lecture and 64–72 laboratory. This course acquaints students with restaurant and banquet operations through theoretical studies and hands on practice. Topics include service styles, guest service, food and wine pairings, staffing, mise en place, cost control and the leadership skills required to effectively manage restaurant and banquet operations. \$50.00 Material Fee — Payable at Registration. (CSU)

HRC 135 C Culinary Fundamentals I**3 Units**

Prerequisite: HRC 120 C with a minimum grade of "C."

Term hours: 32–36 lecture and 64–72 laboratory. Great cuisine rests on the mastery of seemingly simple preparations and techniques that determine the quality of the final product. This course will focus on the basic principles, skills, and techniques associated with culinary arts, involving various cooking methods including classic and modern techniques. Students will identify various kitchen items to include; food products and equipment used within the commercial food operation. \$75.00 Material Fee — Payable at Registration. (CSU)

HRC 136 C Baking Fundamentals I**3 Units**

Prerequisite: HRC 120 C with a minimum grade of "C."

Term hours: 32–36 lecture and 64–72 laboratory. Well-executed desserts rely on a mastery of fundamental techniques. This course will focus on the history of baking, terminology, ingredients, equipment, storage and sanitation in the bakeshop. Students will gain experience in using various mixing, holding and baking methods as well as international techniques to create an assortment of yeast dough, quick breads, prepare enriched yeast dough, cookies, pies, tarts and cakes. \$75.00 Material Fee — Payable at Registration. (CSU)

HRC 144 C Quantity Cooking Techniques 3 Units

Advisory: Completion of or concurrent enrollment in HRC 120 C and HRC 135 C.

Term hours: 32–36 lecture and 64–72 laboratory. The production kitchen is the backbone of every major commercial food operation. Students will be introduced to the principles of quantity food production; standardized recipes; quality and hazard analysis; yields and principles of cooking in quantity. Students will become familiar with a wide variety of equipment utilized in production kitchens. \$75.00 Material Fee — Payable at Registration. (CSU)

HRC 145 C The Art of Garde Manger 3 Units

Prerequisite: HRC 120 C and HRC 135 C with minimum grades of "C."

Term hours: 32–36 lecture and 64–72 laboratory. Hors d'oeuvres and appetizers challenge the chef to create masterpieces in miniature. This course will focus on the discussion and application of the art of Garde Manger to include hot and cold hors d'oeuvres (canapés, finger sandwiches and savories); cold set mousses; the principles and applications necessary for sausage making; concepts and application of salt curing of meats and fish items and principles of smoking. \$95.00 Material Fee — Payable at Registration. (CSU)

HRC 152 C Menu Planning and Purchasing 3 Units

Prerequisite: HRC 101 C with a minimum grade of "C."

Term hours: 48–54 lecture. This course examines the principles of menu planning, hospitality procurement, purchasing, receiving, and inventory techniques. Strategies for menu analysis, standardized recipes, menu layout and design relating to profitable hospitality operations will be explored. (CSU)

HRC 160 C Rooms Division Operations 3 Units

Advisory: ENGL 060 C.

Term hours: 48–54 lecture. This course presents an overview of hotel rooms division operations from reservations through guest stay and account settlement. Students will learn hotel best practices to include revenue management, preventative maintenance, property management systems, supervision, cost control, staffing, sales techniques and guest relations. (CSU)

HRC 164 C Hospitality Law 3 Units

Prerequisite: Completion of or concurrent enrollment in HRC 101 C with a minimum grade of "C."

Term hours: 48–54 lecture. This course presents legal aspects of managing hospitality operations with an emphasis on compliance best practices and prevention of liabilities. Topics include serving food safely, responsible alcohol service, selecting and managing employees, regulatory concerns, property management, hospitality operating structures, common contracts, safety and security, and crisis management. (CSU)

HRC 166 C Managing Guest Relations 3 Units

Term hours: 48–54 lecture. This course is designed to provide the student with the basic knowledge of "service" and how it applies to managing guest relations. Service will be examined from the perspective of those who deliver it and those who manage it. A pragmatic approach to the problems of personnel management in the hospitality and travel industry will be discussed. (CSU)

HRC 230 C Hotel Management 3 Units

Prerequisite: HRC 101 C with a minimum grade of "C."

Term hours: 48–54 lecture. This course explores hotel management strategies and operations in hotel rooms division, food and beverage, engineering, loss prevention, marketing, sales, accounting, information management and human resources. Case study analysis will focus on leadership principles and ethical considerations in the hotel industry. (CSU)

HRC 231 C Cost Control in Hospitality 3 Units

Term hours: 48–54 lecture. This course presents the principles of cost control and revenue management. Topics include: managing revenue and expenses, determining sales forecasts, managing the cost of food, beverages and labor, the production process, pricing, analyzing results, planning for profits, maintaining a revenue control system and using technology to help enhance controls. Students learn to identify and solve problems to help keep costs low and profit margins high in hospitality operations. (CSU)

HRC 232 C Special Event Management 3 Units

Prerequisite: HRC 101 C.

Term hours: 48–54 lecture. The course is a comprehensive study of the field of special events with emphasis on creating and executing catered events. Topics include: special event venues, event organization and management, skills and abilities for event managers. (CSU)

HRC 235 C Culinary Fundamentals II 3 Units

Prerequisite: HRC 120 C and HRC 135 C with minimum grades of "C."

Term hours: 32–36 lecture and 64–72 laboratory. Great chefs rest on mastering the advanced techniques utilized in today's commercial kitchens. The most crucial is flavor development, which students begin to learn at the start of their studies. This course will focus on the principles, skills, and techniques associated with advanced culinary arts, involving fabrication and identification of common proteins utilized in commercial operations. \$75.00 Materials Fee — Payable at Registration. (CSU)

HRC 236 C Baking Fundamentals II 3 Units

Prerequisite: Completion of or concurrent enrollment in HRC 120 C and HRC 136 C.

Term hours: 32–36 lecture and 64–72 laboratory. Creating classic cakes and tortes, artisan breads and frozen desserts calls for creativity and technical understanding. This course focuses on advanced pastries and bread production. Products include classical cakes and tortes, frozen desserts, artisan breads and Viennoiserie. Emphasis will be placed on commercial production of high quality products and professional presentation. \$95.00 Material Fee — Payable at Registration. (CSU)

HRC 246 C Pastry Arts 3 Units

Prerequisite: HRC 120 C and HRC 236 C with minimum grades of "C."

Term hours: 32–36 lecture and 64–72 laboratory. Candy making, cake decorating, and dessert plating represent the ultimate fusion of art and craft. This course focuses on pastry arts to include restaurant style desserts, confections, special occasion cakes and pastry showpieces. Emphasis will be placed on commercial production of high quality products and professional presentation. \$95.00 Material Fee — Payable at Registration. (CSU)

HRC 255 C American Regional Cuisine 3 Units

Prerequisite: HRC 120 C and HRC 235 C or HRC 236 C with minimum grades of "C."

Term hours: 32–36 lecture and 64–72 laboratory. This culinary tour of America includes product identification, correct utilization and cooking methods. This course focuses on a regional perspective of American cuisine. Students will have the opportunity to produce regional specialties while researching the influence of culture on the development of American cuisine. \$75.00 Material Fee — Payable at Registration. (CSU)

HRC 265 C International Cuisine 3 Units

Prerequisite: HRC 120 C and HRC 235 C or HRC 236 C with minimum grades of "C."

Term hours: 32–36 lecture and 64–72 laboratory. This culinary tour of the world includes product identification, correct utilization and cooking methods. This course focuses on a global perspective of various regional cuisines. Students will have the opportunity to produce ethnic foods while researching the influence of culture on the development of international cuisines. \$75.00 Material Fee — Payable at Registration. (CSU)

HRC 295 C Hospitality Internship 3 Units

Prerequisite: Completion of first year hotel, food service or culinary arts program recommended.

Term hours: 16–18 lecture and 240–288 laboratory. The Hospitality Internship class is the link between academic learning and industry experience. This course requires a minimum of 255 hours work experience with an instructor approved employer in the hotel, restaurant or culinary arts field. Students will compile a comprehensive career portfolio. (CSU)

HRC 298 C Hospitality Seminar .5 to 12 Units

Prerequisite: May be required.

Corequisite: May be required.

Advisory: May be required.

Term hours: 0–216 lecture and/or 0–1620 laboratory depending on units attempted. This course is for students who wish to increase their knowledge of the hotel, restaurant, and/or culinary arts industries. Various topics will be offered. Unit credit may range from .5 to 12 units in any given semester. Consult the class schedule to verify credit for a particular semester. May be taken for credit 1–4 times. Pass/No Pass or Pass/No Pass/Letter Grade Option or Standard Letter Grade. Fees may be required — Payable at Registration. (CSU)

Human Services

Division of Social Sciences

Division Dean, Nina DeMarkey

Faculty

Virgil Adams, III

Gary Zager

Counselors

Velia Lawson

Therese Mosqueda-Ponce

Daniel Pelletier

PROGRAM LEARNING OUTCOMES (PLOs)

The courses taught by this department contribute to the General Education and Basic Skills Program Learning Outcomes. Please refer to General Education and Basic Skills Program Learning Outcomes.

ASSOCIATE IN ARTS DEGREE

HUMAN SERVICES

Program Code: 1A03803

The Human Services Program for the Associate in Arts Degree prepares students for a variety of careers in public and private social service agencies. Course work includes completion of 24 units plus 12 elective units in one or more specialty areas of Alcohol and Drug Studies, Conflict Resolution, Criminal Justice, Family Studies, Gerontology, Human Services Generalist, and Victimology.

To earn an Associate Degree students must complete: (1) all major course requirements with a minimum grade of "C"; (2) 25 units of General Education Graduation Requirements; (3) any elective courses to complete a minimum of 60 units; and, (4) with an overall GPA of 2.0. At least 50% of all major course work must be completed at Cypress College.

Courses that fulfill major requirements for an Associate Degree at Cypress College might not be the same as those required for completing the major at a transfer institution offering a Baccalaureate Degree. For information on specific university requirements, please consult with your counselor, or visit the Transfer Center.

Required courses are listed in suggested sequence:

Course #	Title	Units
HUSR 200 C	Introduction to Human Services	3
HUSR 222 C	Group Leadership and Group Process	3
HUSR 224 C	Self-Esteem Strategies	3
HUSR 210 C	Introductory Fieldwork	3
HUSR 225 C	Families and Substance Abuse	3
HUSR 241 C	Intervention Treatment and Recovery	3
PSY 139 C	Developmental Psychology	3
HUSR 211 C	Advanced Fieldwork	3
Select a minimum of 12 units from the elective courses listed below		12
Total Units Required		36

Electives (Select 12 units from below)

COUN 140 C	Educational Planning	.5
ETHS 101 C	American Ethnic Studies	3
	or	
ETHS 101HC	Honors American Ethnic Studies	(3)
HUSR 215 C	Introduction to Family Studies	3
HUSR 221 C	Crisis Intervention and Referral	3
HUSR 223 C	Helping Skills in Human Services	3
HUSR 226 C	Behavior Modification Techniques	3
HUSR/SOC 250 C	Sociology of Aging	3
HUSR/PSY 255 C	Psychology of Aging	3
HUSR 291 C	Counseling in Criminal Justice	3
HUSR/SOC 292 C	Introduction to Criminology	3
HUSR 294 C	Careers in Criminal Justice	3
HUSR 240 C	Drugs and Alcohol in Our Society	3
HUSR 242 C	Drugs and Physiology	3
HUSR 243 C	Co-Occurring Disorders	3
HUSR 270 C	Introduction to Victimology	3
HUSR 271 C	Society and Victimization	3
HUSR 275 C	Ethical Issues in Human Services	3
HUSR 281 C	Prevention Strategies	3
HUSR 293 C	Conflict Resolution/Mediation	3

HUMAN SERVICES CERTIFICATE PROGRAMS

The Human Services Department includes certificate programs in Alcohol and Drug Studies, Conflict Resolution, Criminal Justice, Family Studies (Basic and Advanced), Gerontology, Human Services Generalist, and Victimology. Each specialization recommends a core of required courses including fieldwork experience, and 6 to 12 units of specialization courses. The curricula are designed so that students with interests in several areas can complete more than one certificate program in an effective and efficient manner. The California Association of Alcohol/Drug Educators approves the Alcohol and Drug Certificate program. The Conflict Resolution Certificate prepares students to assist in the resolution of conflict in various settings including home and work with an emphasis on human relations in business, management positions in treatment facilities, and issues in victimology and cross-cultural conflict. The Criminal Justice Certificate will prepare students to work with Human Service agencies that provide services to clients coming from the criminal justice system. Family Studies Certificates offer the student the opportunity to examine today's changing family needs, values and patterns as well as to form the foundation for a career in family studies professions. The Gerontology Certificate explores appropriate human service agencies, intervention strategies, and the adaptive and maladaptive behaviors of the normal aging process for the individual and their family. The Victimology Certificate examines the network of agencies available for victims and perpetrators as well as the variety of methods for dealing with this issue. The Human Services Generalist Certificate has training applicable in all Human Service areas.

ALCOHOL AND DRUG STUDIES CERTIFICATE Program Code: 1C07845

To earn a certificate, students must complete the required courses as listed with a minimum grade of "C." At least 50% of all course work must be completed at Cypress College.

Required courses are listed in suggested sequence:

Course #	Title	Units
HUSR 200 C	Introduction to Human Services	3
PSY 139 C	Developmental Psychology	3
HUSR 210 C	Introductory Fieldwork	3
HUSR 211 C	Advanced Fieldwork	3
HUSR 225 C	Families and Substance Abuse	3
HUSR 240 C	Drugs and Alcohol in Our Society	3
HUSR 241 C	Intervention Treatment and Recovery	3
HUSR 242 C	Drugs and Physiology	3
Select a minimum of 12 units from the elective courses listed below		12
Total Units Required		36

Electives

COUN 140 C	Educational Planning	.5
ETHS 101 C	American Ethnic Studies	3
or		
ETHS 101HC	Honors American Ethnic Studies	(3)
HUSR 221 C	Crisis Intervention and Referral	3
HUSR 222 C	Group Leadership and Group Process	3
HUSR 223 C	Helping Skills in Human Services	3
HUSR 224 C	Self-Esteem Strategies	3
HUSR 226 C	Behavior Modification Techniques	3
HUSR 243 C	Co-Occurring Disorders	3
HUSR 270 C	Introduction to Victimology	3
HUSR 275 C	Ethical Issues in Human Services	3
HUSR 281 C	Prevention Strategies	3
HUSR 290 C	Human Services in Criminal Justice	3
HUSR 291 C	Counseling in Criminal Justice	3

CONFLICT RESOLUTION CERTIFICATE

Program Code: 1K17141

This program offers those entering or working in human services the opportunity to examine and practice a variety of communication skills useful in the resolution of conflict.

To earn a certificate, students must complete the required courses as listed with a minimum grade of "C." At least 50% of all course work must be completed at Cypress College.

Required courses are listed in suggested sequence:

Course #	Title	Units
HUSR 293 C	Conflict Resolution/Mediation	3
HUSR 275 C	Ethical Issues in Human Services	3
MGT 266 C	Human Relations in Business	3
HUSR 210 C	Introductory Fieldwork	3
Select a minimum of 3 units from elective courses below		3
Total Units Required		15

Electives

HUSR 222 C	Group Leadership/Group Process	3
HUSR 270 C	Introduction to Victimology	3
ETHS 101 C	American Ethnic Studies	3
or		
ETHS 101HC	Honors American Ethnic Studies	(3)
SOC/PSY 237 C	Cross-Cultural Relationships	3
COMM 105 C	Interpersonal Communication	3

CRIMINAL JUSTICE CERTIFICATE Program Code: 1C12113

This certificate program will prepare students to work with Human Service agencies that provide services to clients coming from the criminal justice system. Students will examine the skill requirements, the major tasks and responsibilities, the role and function of the service provider in jails, penal institutions, police departments, juvenile justice agencies and the Department of Corrections.

To earn a certificate, students must complete the required courses as listed with a minimum grade of "C." At least 50% of all course work must be completed at Cypress College.

Required courses are listed in suggested sequence:

Course #	Title	Units
HUSR 223 C	Helping Skills in Human Services	3
HUSR 224 C	Self-Esteem Strategies	3
HUSR 275 C	Ethical Issues in Human Services	3
HUSR 210 C	Introductory Fieldwork	3
HUSR 290 C	Human Services in Criminal Justice	3
HUSR 291 C	Counseling in Criminal Justice	3
HUSR/SOC 292 C	Introduction to Criminology	3
HUSR 294 C	Careers in Criminal Justice	3
HUSR 295 C	Cross-Cultural Criminology	3
HUSR 211 C	Advanced Fieldwork	3
Select a minimum of 9 units from elective courses below		9
Total Units Required		39

Electives (Select 9 units from the list below)

HUSR 221 C	Crisis Intervention and Referral	3
HUSR 240 C	Drugs and Alcohol in Our Society	3
HUSR 241 C	Intervention Treatment and Recovery	3
HUSR 242 C	Drugs and Physiology	3
HUSR 270 C	Introduction to Victimology	3
HUSR 271 C	Society and Victimization	3
HUSR 293 C	Conflict Resolution/Mediation	3

FAMILY STUDIES (BASIC) CERTIFICATE

Program Code: 1K03792

The Family Studies (BASIC) Certificate Program in Human Services is designed to prepare the student for the personal challenges of relationships and child rearing as well as to form a foundation for a career in the Family Studies professions.

To earn a certificate, students must complete the required courses as listed with a minimum grade of "C." At least 50% of all course work must be completed at Cypress College.

Required courses are listed in suggested sequence:

Course #	Title	Units
HUSR 215 C	Introduction to Family Studies	3
PSY 139 C	Developmental Psychology	3
PSY/SOC 215 C	Parenting Skills	3
SOC 275 C	Marriage and Family	3
Select a minimum of 3 units from the elective courses listed below		3
Total Units Required		15

Electives (Select 3 units from the list below)

COUN 140 C	Educational Planning	.5
ENGL 239 C	Survey — Children's Literature	3
HUSR 224 C	Self-Esteem Strategies	3
HUSR 240 C	Drugs and Alcohol in Our Society	3
HUSR/PSY 255 C	Psychology of Aging	3
HUSR/SOC 250 C	Sociology of Aging	3
HUSR 270 C	Introduction to Victimology	3
PSY/SOC 120 C	Human Sexuality	3

FAMILY STUDIES (ADVANCED) CERTIFICATE

Program Code: 1C10452

The Family Studies (ADVANCED) Certificate Program in Human Service is designed as a more complete examination of the many individual and family needs resulting from changing family patterns. Needed skills include parenting in a variety of family situations, communicating in healthy relationships, caregiving in intergenerational families and coping with stress. This program prepares the student in three ways: (1) Providing courses as personal enrichment for the families and individuals in the community; (2) Training Human Service workers for employment in schools, health and mental health agencies, rehabilitation centers, halfway houses, senior centers and as support persons to law enforcement and other community agencies; and (3) Providing the first two years of courses for Family Studies professions such as therapist and administrator which require further college education.

To earn a certificate, students must complete the required courses as listed with a minimum grade of "C." At least 50% of all course work must be completed at Cypress College.

Required courses are listed in suggest sequence:

Course #	Title	Units
HUSR 200 C	Introduction to Human Services	3
HUSR 215 C	Introduction to Family Studies	3
HUSR 224 C	Self-Esteem Strategies	3
SOC 275 C	Marriage and Family	3
PSY/SOC 215 C	Parenting Skills	3
HUSR 210 C	Introductory Fieldwork	3
PSY 139 C	Developmental Psychology	3
HUSR 270 C	Introduction to Victimology	3
Select a minimum of 6 units from the elective courses listed below		6
Total Units Required		30

Electives (Select 6 units from the list below.)

COUN 140 C	Educational Planning	.5
ENGL 239 C	Survey — Children's Literature	3
ETHS 101 C	American Ethnic Studies	3
or		
ETHS 101HC	Honors American Ethnic Studies	(3)
HUSR 221 C	Crisis Intervention and Referral	3
HUSR 222 C	Group Leadership and Group Process	3
HUSR 223 C	Helping Skills in Human Services	3
HUSR 225 C	Families and Substance Abuse	3
HUSR 226 C	Behavior Modification Techniques	3
HUSR 240 C	Drugs and Alcohol in Our Society	3
HUSR/PSY 255 C	Psychology of Aging	3
HUSR/SOC 250 C	Sociology of Aging	3
HUSR 275 C	Ethical Issues in Human Services	3
PSY 120 C	Human Sexuality	3

GERONTOLOGY CERTIFICATE

Program Code: 1K07842

The Gerontology Certificate Program in Human Services is a collection of interdisciplinary courses that prepare students to bring expertise, intervention skills and understanding about the aging adult to work and to family settings. Older adult development, and adaptive and maladaptive behaviors of the normal aging process are explored. Emphasis will be placed on critical life issues such as health, mental health, care giving, social support, living arrangements, work and retirement, and human service resources. Death and dying, and the ethical issues that often occur during the last years of life will be examined.

To earn a certificate, students must complete the required courses as listed with a minimum grade of "C." At least 50% of all course work must be completed at Cypress College.

Required courses are listed in suggested sequence:

Course #	Title	Units
HUSR 200 C	Introduction to Human Services	3
HUSR 210 C	Introductory Fieldwork	3
HUSR/SOC 250 C	Sociology of Aging	3
HUSR/PSY 255 C	Psychology of Aging	3
Total Units Required		12

Select 3 units from the elective courses listed below.

HUSR 275 C	Ethical Issues in Human Services	3
HUSR 215 C	Introduction to Family Studies	3
HUSR 221 C	Crisis Intervention and Referral	3
PE 235 C	First AID, CPR and Emergencies	3
PSY/SOC 120 C	Human Sexuality	3

HUMAN SERVICES GENERALIST CERTIFICATE

Program Code: 1C21122

To earn a certificate, students must complete the required courses as listed with a minimum grade of "C." At least 50% of all course work must be completed at Cypress College.

Required courses are listed in suggested sequence:

Course #	Title	Units
HUSR 200 C	Introduction to Human Services	3
HUSR 222 C	Group Leadership and Group Process	3
HUSR 224 C	Self Esteem Strategies	3
HUSR 210 C	Introductory Fieldwork	3
HUSR 225 C	Families and Substance Abuse	3
HUSR 241 C	Intervention Treatment and Recovery	3
PSY 139 C	Developmental Psychology	3
HUSR 211 C	Advanced Fieldwork	3
Select a minimum of 12 units from the elective courses listed below		12
Total Units Required		36

Electives

COUN 140 C	Educational Planning	.5
ETHS 101 C	American Ethnic Studies	3
	or	
ETHS 101HC	Honors American Ethnic Studies	(3)
HUSR 215 C	Introduction to Family Studies	3
HUSR 221 C	Crisis Intervention and Referral	3
HUSR 223 C	Helping Skills in Human Services	3
HUSR 226 C	Behavior Modification Techniques	3
HUSR 240 C	Drugs and Alcohol In Our Society	3
HUSR 242 C	Drugs and Physiology	3
HUSR 243 C	Co-Occurring Disorders	3
HUSR/SOC 250 C	Sociology of Aging	3
HUSR/PSY 255 C	Psychology of Aging	3
HUSR 270 C	Introduction to Victimology	3
HUSR 271 C	Society and Victimization	3
HUSR 275 C	Ethical Issues in Human Services	3
HUSR 281 C	Prevention Strategies	3
HUSR 291 C	Counseling in Criminal Justice	3
HUSR/SOC 292 C	Introduction to Criminology	3
HUSR 294 C	Careers in Criminal Justice	3
PSY/SOC 120 C	Human Sexuality	3

**VICTIMOLOGY
CERTIFICATE**

Program Code: 1C07847

The study of Victimology explores the costs of victimization in our society today and the variety of methods, current and proposed, for dealing with the issues. Courses provide an in-depth examination of both the victim and the perpetrator. Resources for victims of violent and non-violent crimes are discussed and professionals present various points of view.

To earn a certificate, students must complete the required courses as listed with a minimum grade of "C." At least 50% of all course work must be completed at Cypress College.

Required courses are listed in suggested sequence:

Course #	Title	Units
HUSR 200 C	Introduction to Human Services	3
HUSR 210 C	Introductory Fieldwork	3
HUSR 211 C	Advanced Fieldwork	3
HUSR 225 C	Families and Substance Abuse	3
HUSR 270 C	Introduction to Victimology	3
HUSR 271 C	Society and Victimization	3
HUSR 290 C	Human Services in Criminal Justice	3
Select a minimum of 9 units from the elective courses listed below		9
Total Units Required		30

Electives (Select 9 units from below.)

COUN 140 C	Educational Planning	.5
ETHS 101 C	American Ethnic Studies	3
	or	
ETHS 101HC	Honors American Ethnic Studies	(3)
HUSR 221 C	Crisis Intervention and Referral	3
HUSR 222 C	Group Leadership and Group Process	3
HUSR 223 C	Helping Skills in Human Services	3
HUSR 224 C	Self-Esteem Strategies	3
HUSR 226 C	Behavior Modification Techniques	3
HUSR 240 C	Drugs and Alcohol in Our Society	3
HUSR 275 C	Ethical Issues in Human Services	3
PSY 139 C	Developmental Psychology	3

OFF-CAMPUS PROGRAMS

Cypress' Human Services Department provides flexible, off-campus courses and workshops to further meet the education and training needs of human services. Specially designed training is available to meet the needs of community leaders, professionals, paraprofessionals, volunteers, community groups and organizations. For further information, contact the Human Services Department.

TRANSFER PROGRAM — HUMAN SERVICES

The student in human services has the option of completing an Associate in Arts degree with a major in Human Services by completing the general education requirements in addition to the Certificate Program. The program is also designed for students who plan to continue with professional preparation at the university level in social work, human services, criminal justice, gerontology, counseling, and related social service fields.

Students should consult a counselor or www.assist.org for lower division major requirements for most California public universities. (See the Standard Definitions section of the catalog for a description of ASSIST.) Students transferring to an independent college/university should consult the catalog of the individual school and a counselor for lower division major requirements.

Human Services (HUSR)

HUSR 084 C Introduction to Behavior Modification .5 Units

Term hours: 8–9 lecture. This course is for individuals working in programs for developmentally disabled persons, as well as those interested in the field. It will cover basic information about behaviorally oriented work with such clients, including content on behavior modification, teaching methods and ways to encourage clients.

HUSR 200 C Introduction to Human Services 3 Units

Term hours: 48–54 lecture. This course covers the history and philosophy of the human services; function and orientation of human services agencies and institutions; human services as careers; opportunities and qualifications at various entry levels of human services employment. (CSU, CSU GE)

HUSR 210 C Introductory Fieldwork 3 Units

Term hours: 16–18 lecture and 125 laboratory. This course offers observation and participation in the operations of human services agencies. The student will document 125 hours of supervised field study per semester and will attend one hour lecture per week. Pass/No Pass/Letter Grade Option. (CSU)

HUSR 211 C Advanced Fieldwork 3 Units

Prerequisite: HUSR 210 C.

Term hours: 16–18 lecture and 125 laboratory. This course is the second of a two-semester sequence of volunteer or paid fieldwork experience. The student will apply values, concepts and skills of core human services courses to the actual process of helping people. Emphasis of this semester is on sharpening skills and knowledge gained in the introductory field experience. There is one hour of classroom experience per week. Pass/No Pass/Letter Grade Option. (CSU)

HUSR 215 C Introduction to Family Studies 3 Units

Term hours: 48–54 lecture. This course involves intergenerational family studies and related career exploration to introduce Human Services students to family issues and to skills, theories, and competencies needed to empower families for reaching their goals. Various family issues, family/worker relationships, strength-based assessments, resource referral/utilization, community service coordination, and family and worker stress management are covered. (CSU)

HUSR 221 C Crisis Intervention and Referral 3 Units

Term hours: 48–54 lecture. This course introduces techniques for beginning crisis counseling, including recognition of crisis, assessment of crisis, and referral to the appropriate crisis agency. Special attention will be given to the process of intervention and to the recording of information regarding problems with alcohol and other drugs. Participants will implement a variety of crisis skills through an experiential format. (CSU)

HUSR 222 C Group Leadership and Group Process 3 Units

Term hours: 48–54 lecture. This course examines membership and leadership in a variety of groups, with emphasis on the total group process. An overview of the various types of groups will be given as well as the values and limitations of groups, cautions and risks of groups and common misconceptions about groups. The student will be offered experience as a group member and a group leader. (CSU)

HUSR 223 C Helping Skills — Human Services 3 Units

Term hours: 48–54 lecture. This course involves identification and application of specific helping skills in intrapersonal and interpersonal relations. It is designed for persons in helping roles, professional and paraprofessional, or volunteers in Human Services. (CSU)

HUSR 224 C Self-Esteem Strategies 3 Units

Term hours: 48–54 lecture. This course is designed for those considering a career in management and staff development in Human Services Agencies, with special application to client after-care programs. Theory and technique are combined in this skills class to assist case managers and program directors with assessment and evaluation, individual recovery program development, educational process and materials, and utilization of resources and referral procedures. This course focuses on issues of self-esteem, concept formation, problem solving, time management, emotional intelligence, and decision making for client and/or staff development. (CSU)

HUSR 225 C Families and Substance Abuse 3 Units

Term hours: 48–54 lecture. This course presents the dynamics of the family system as they are affected by addiction. Theories of healthy and unhealthy family interaction are explored and the experiential format provides the opportunity for skill development and practical experience. (CSU)

HUSR 226 C Behavior Modification 3 Units

Term hours: 48–54 lecture. This course includes both theory and practice in behavior modification principles. It teaches skills such as observing and recording behavior, uses of reinforcement, extinction, punishment, etc. Self management techniques to assist in control of one's own behavior will also be discussed. Topics have wide application in any course of study and will require dealing effectively with others, or with more effective management of oneself. (CSU)

HUSR 228 C Group Process and Practice 3 Units

Advisory: Completion of HUSR 222 C.

Term hours: 48–54 lecture. This course will investigate group dynamics and process as they relate to group theory. Students will participate in group change and counseling demonstrations in class. Related legal and ethical issues will be discussed. (CSU)

HUSR 240 C Drugs and Alcohol in Our Society 3 Units

Term hours: 48–54 lecture. This is an introductory course for individuals in any area of human services who desire to increase their knowledge regarding problems resulting from drug and/or alcohol abuse and addiction. This course will cover the basic casual theories of alcoholism, identification of signs and symptoms, dispel “myths” and provide information on past and current treatment modalities. Students will be introduced to the history of drug use in general; their misuse and abuse, including societal methods implemented for their regulation and control. (CSU)

HUSR 241 C Intervention Strategies 3 Units

Term hours: 48–54 lecture. This course will serve as an assessment and treatment approach to individuals having problems with alcohol and other drugs. Alcoholism will be studied in its social and clinical context. Attention will be given to basic theoretical approaches to the disease. Major emphasis will be on the philosophical and clinical approaches to treating the alcoholic and to promoting recovery. (CSU)

HUSR 242 C Drugs and Physiology 3 Units

Term hours: 48–54 lecture. This course explores the effects of alcohol and other drugs on the body. It examines the physiology of alcohol in two areas: (1) physical effects of alcohol on the body, and (2) the physiological effects of the disease processes associated with heavy drinking. (CSU)

HUSR 243 C Co-Occurring Disorders 3 Units

Term hours: 48–54 lecture. This course will introduce the student to the treatment needs of those who have a psychiatric disorder in combination with a chemical dependency disorder. Students learn to identify and assess those with a dual diagnostic/co-occurring disorder. Pass/No Pass/Letter Grade Option. (CSU)

HUSR 250 C Sociology of Aging 3 Units

Same as SOC 250 C.

Term hours: 48–54 lecture. This course explores the concept of aging and sociological/cultural theories of aging. The gender, cross-cultural, economic, political and social policy aspects of aging in society and the world are examined. Critical life issues for elders and for those who live and work with them are explored. These issues include empowerment, care giving, social support, living arrangements, elder abuse, work, retirement, quality of life and death and dying. Duplicate credit not granted for SOC 250 C. (UC/CSU, AA GE, CSU GE, IGETC)

HUSR 255 C Psychology of Aging 3 Units

Same as PSY 255 C.

Term hours: 48–54 lecture. This course examines the biological, physiological, cognitive, personality, developmental, and sexual aspects of the ongoing aging process. Critical life issues for elders and for those who live and work with them will be explored. These issues include physical health, mental health, health care policy, care giving, dependency, and positive aging strategies. Duplicate credit not granted for PSY 255 C. (UC/CSU, AA GE, CSU GE, IGETC)

HUSR 270 C Introduction to Victimology 3 Units

Term hours: 48–54 lecture. This course responds to the emerging social concern regarding the cost of victimization to our society today. It provides education, information on existing resources, and direct participation in the creation and expansion of existing resources of treatment and recovery of victims and perpetrators. (CSU)

HUSR 271 C Society and Victimization 3 Units

Term hours: 48–54 lecture. This course will provide an understanding of the social problems of victimization with in-depth focus on both perpetrator and victim. Specific issues will be explored including their genesis and specific methods of identifying issues regarding self-help and support activities from a clinical approach. (CSU)

HUSR 275 C Ethical Issues in Human Services 3 Units

Term hours: 48–54 lecture. This course presents the rules and standards governing the professional conduct of those working in Human Services Agencies. Issues of client/patient rights, confidentiality, physical and emotional abuse, and counselor/client relationships will be explored in great depth. (CSU)

HUSR 281 C Prevention Strategies 3 Units

Term hours: 48–54 lecture. This course will present the history, theories and current strategies for prevention of alcohol and drug problems and for reduction of harm caused by those with problems (harm reduction). Conceptual frameworks, major research, epidemiology, environmental risk factors and the effectiveness of various prevention strategies will be examined. (CSU)

HUSR 290 C Human Services in Criminal Justice 3 Units

Term hours: 48–54 lecture. This experiential course will survey the historical, and philosophical aspects of criminal behavior and the functions and objectives of parole and probation. Students will examine the skill requirements, the major tasks and responsibilities, the role and function and the overall mission of the service provider in the criminal justice system. The judicial system and its relationship to the criminal offender will be examined as well as modern approaches in the control of crime. Resources for resocializing the offender will be explored. (CSU)

HUSR 291 C Counseling in Criminal Justice 3 Units

Term hours: 48–54 lecture. This course explores current theory and practice in the counseling of those in state prison treatment programs. Topics include an overview of the California Department of Corrections, the inmate classification system, specialized inmate management topics, violence and violence management strategies, victim awareness issues, the processes of addiction and recovery, an overview of assessment instruments, an exploration of sociopathy, and group counseling dynamics. (CSU)

HUSR 292 C Introduction to Criminology 3 Units

Same as SOC 292 C.

Term hours: 48–54 lecture. This course presents a scientific analysis of the nature, extent, and causes of violations of societal rules of behavior that are formally defined as crime and delinquency. The course includes an analysis of the theoretical perspectives that led to the development of criminal law and the administration of criminal justice, the patterns of criminality and delinquency, the impact of crime on social change, and the labeling, identification, characteristics, and the treatment of criminals and delinquents. Duplicate credit not granted for SOC 292 C. (UC/CSU, CSU GE, IGETC)

HUSR 293 C Conflict Resolution/Mediation 3 Units

Course hours 48–54. This course examines the background, development and methodology of non-violent, non-litigious conflict resolution with emphasis on theory and the practice of mediation. This is a state certified course designed to train individuals to be effective in resolving conflict in the family, the community, the classroom and the workplace. Pass/No Pass/Letter Grade Option. (CSU)

HUSR 294 C Careers in Criminal Justice 3 Units

Term hours: 48–54 lecture. This course will provide the student with the opportunity to explore, in-depth, the breadth and scope of career opportunities in the field of criminal justice. Specific careers will be explored through guest speakers, field trips, on-site observations and mentoring opportunities. Students will gather knowledge and gain an appreciation for the criminal justice field as a result of this course. Pass/No Pass/Letter Grade Option. (CSU)

HUSR 295 C Cross-Cultural Criminology 3 Units

Term hours: 48–54 lecture. This course will explore cross-cultural customs and traditions from a criminal justice perspective. Specific cultures that are represented in significant numbers within the United States will be explored. Students will gather knowledge and gain an appreciation for the cross-cultural aspects within the field of criminal justice. Pass/No Pass/Letter Grade Option. (CSU, CUL DIV)

HUSR 298 C Human Services Seminar .5 to 3 Units

Prerequisite: May be required.

Corequisite: May be required.

Advisory: May be required.

Term hours: 0–216 lecture and/or 0–756 laboratory depending on units attempted. This is a lecture/discussion type course dealing with a particular limited problem or topic of interest to students. It is designed for students who wish to increase their knowledge of a particular topic that is offered in no other regular class. A paper or group activity may be assigned. Credit may range from .5 to 12 units. Consult class schedule for the offerings a particular semester. May be taken for credit 1–4 times. Pass/No Pass or Pass/No Pass Letter Grade Option or Standard Letter Grade. Fees may be required — Payable at Registration. (UC Credit Limitation/CSU)

Industrial Education Teaching

INDUSTRIAL EDUCATION TEACHING TRANSFER PROGRAM

Students should consult a counselor or www.assist.org for lower division major requirements for most California public universities. (See the Standard Definitions section of the catalog for a description of ASSIST.) Students transferring to an independent college/university should consult the catalog of the individual school and a counselor for lower division major requirements.

Information Systems (IS) — See Computer Information Systems (CIS)

INFORMATION SYSTEMS TRANSFER PROGRAM

Refer to Catalog under: BUSINESS ADMINISTRATION TRANSFER PROGRAM

Students should consult a counselor or www.assist.org for lower division major requirements for most California public universities. (See the Standard Definitions section of the catalog for a description of ASSIST.) Students transferring to an independent college/university should consult the catalog of the individual school and a counselor for lower division major requirements.

Information Technology (IT) — See Computer Information Systems (CIS)

Interdisciplinary Studies

All Divisions

All Division Deans

Faculty

Linda Borla

Counselors

All Counselors

PROGRAM LEARNING OUTCOMES (PLOs)

The courses taught by this department contribute to the General Education and Basic Skills Program Learning Outcomes. Please refer to General Education and Basic Skills Program Learning Outcomes.

Option III — GENERAL STUDIES

A.A. Degree **Program Code: 1A18452**

A.S. Degree **Program Code: 1S12078**
(Inactive)

EMPHASIS IN FINE ARTS

This Area of Emphasis under the Option III — General Studies provides students with the opportunity to earn an Associate in Arts degree, allowing them to understand the intellectual relationships between various disciplines in the Arts. This degree option may include transfer and/or non-transfer coursework. Please consult with a counselor for more information.

The Associate of Art Degree in Fine Arts provides students with a scope of knowledge and broad overview for attaining the communication skills, practical knowledge, and training necessary for a variety of careers in the Fine Arts area. Students completing this degree will develop a basic understanding of the arts and how they interrelate. To earn an Associate Degree students must complete (1) all course requirements with a minimum grade of "C"; (2) 25 units of General Education Graduation Requirements; (3) the cultural diversity and reading requirements; (4) any elective courses to complete a minimum of 60 units; and (5) have a minimum GPA of 2.0. At least 50% of all course work must be completed at Cypress College. Courses that fulfill requirements in an area of emphasis for Associate Degree at Cypress College might not be the same as those required for completing the major at a transfer institution offering a Baccalaureate Degree.

An Associate in Arts Degree includes at least 20 units in Social Sciences, Humanities and Arts courses. An Associate in Science Degree includes at least 20 units in Science, Math and Technical courses.

Required courses:

Course #	Title	Units
ART 110 C	Introduction to Art	3
MAD 101 C	Introduction to Computer Graphics	3
DANC 101 C	Multicultural Dance in the U.S.	3
JOUR 101 C	Reporting and Writing	3
MM 100 C	Introduction to Multimedia	3
MUS 117 C	American Popular Music History	3
PHOT 101 C	Introduction to Photography	3
THEA 100 C	Introduction to the Theatre	3
Total Units Required		24

Electives:

To complete all course requirements, students must complete 11 additional units from the list below for a total of 35 units.

No more than six units from any one discipline can be counted towards these units.

Select up to six units

ART 120 C	Two-Dimensional Design	3
ART 122 C	Gallery/Portfolio Design	3
ART 130 C	Printmaking	3
ART 140 C	Advertising/Graphic Design 1	3
ART 150 C	Ceramics Handbuilding	3
ART 182 C	Freehand Drawing	3

Select up to six units

MAD 102 C	Introduction to MAC Web Graphics or	3
MAD 103 C	Introduction to WIN Web Graphics	(3)
MAD 104 C	Introduction to MAC 3D Graphics or	3
MAD 105 C	Introduction to WIN 3D Graphics	(3)
MAD 112 C	Electronic Illustration/MAC or	3
MAD 113 C	Electronic Illustrations/WIN	(3)
MAD 134 C	Digital Imaging/MAC or	3
MAD 135 C	Digital Imaging/WIN	(3)
MAD 180 C	Digital Video/MAC	3

Select up to six units

DANC 105 C	Ballet	1.5
DANC 106 C	Classical Dance	2
DANC 107 C	Modern Dance	2
DANC 111 C	Beginning Jazz	1–1.5
DANC 113 C	Tap Dance	1
DANC 115 C	Hip-Hop Dance	1
DANC 130 C	Afro-Caribbean Dance	1
DANC 136 C	Middle Eastern Dance	1
DANC 137 C	Latin and Swing Dance	1

Select up to six units

JOUR 118 C	Introduction to Broadcasting	3
JOUR 140 C	Public Relations and Publicity	3
JOUR 225 C	Newspaper Production	3
JOUR 226 C	Online Production	3
JOUR 228 C	Visualjournalism	3
JOUR 229 C	Broadcast Production	3

Select up to six units

PHOT 103 C	Photographic Possibilities	3
PHOT 109 C	Portrait Photography	3
PHOT 203 C	Lighting and Studio Techniques	3
PHOT 204 C	History/Aesthetics of Early Photog. Practice	3
PHOT 215 C	Digital Photography	3

Select up to six units

MUS 111 C	The Music Business	3
MUS 113 C	Jazz History	3
MUS 119 C	History of Rock Music	3
MUS 126 C	Beginning Voice	1
MUS 130 C	Beginning Guitar	1
MUS 135 C	Beginning Piano	1

Select up to six units

THEA 107 C	Diversity in American Theater	3
THEA 108 C	Stage and Screenwriting	3
THEA 120 C	Acting I	3
THEA 126 C	Musical Theater Techniques	3
THEA 128 C	Acting for the Camera	3
THEA 143 C	Stage Craft	3
THEA 144 C	Lighting Design Fundamentals	3
THEA 145 C	Fundamentals of Costume Design	3
THEA 146 C	Scene Painting	3
THEA 147 C	Stage Makeup	3

Interdisciplinary Studies (INDS)

INDS 092 C Work Experience — General 3 Units

Prerequisite: Must be enrolled in seven units, including work experience.
 Term hours: 16–18 lecture and a minimum of five hours of employment per week for each unit of credit. This course provides students with actual work experience through mutual agreement with selected employers. Work may include the acquisition of desirable work habits and attitudes toward jobs. The job held by the student need not be related to the occupational goal of the student. The student may earn no more than three credit units per semester with a maximum total of six during the student's enrollment in any community college. Student's employment need not be limited to the five-hour increment for which the student gains credit. May be taken for credit 3 times.

INDS 100 C Humanities: Ancient and Medieval 3 Units

Same as ENGL 110 C.
Prerequisite: Eligibility for ENGL 100 C.
 Lecture hours: 48–54 lecture. This course is a survey of the development of Western culture with a focus upon its Greco-Roman roots, and a study of other important influences, including African and Middle Eastern. The course covers prehistory to the Renaissance, with an emphasis on the arts. Duplicate credit not granted for ENGL 110 C. Cost for museum visits not to exceed \$15.00. (UC/CSU, AA GE, CSU GE, IGEC)

INDS 101 C Humanities: Renaissance–Present 3 Units

Same as ENGL 111 C.
Prerequisite: Eligibility for ENGL 100 C.
 Term hours: 48–54 lecture. This course is a survey of the development of Western Culture from the Renaissance to the present, including a study of other important influences from Africa, the Middle East, North and South America, with an emphasis on the arts. Duplicate credit not granted for ENGL 111 C. (UC/CSU, AA GE, CSU GE, IGEC)

INDS 115 C Learning Communities Seminar 1 Unit

Term hours: 16–18 lecture. The Learning Communities Seminar is a course specifically designed for students participating in Learning Communities. Students will use both traditional and electronic tools to research, analyze, discuss, and evaluate materials associated with Learning Community themes. May be taken for credit 2 times. Pass/No Pass/Letter Grade Option. (CSU)

INDS 120HC Honors Program Seminar 1 Unit

Term hours: 48–54 lecture. The Honors Program Seminar is a course specifically designed for Honors Program students. Students will discuss, research, analyze, and write about Honors education issues. (CSU)

Japanese

Division of Language Arts

Division Dean — Eldon Young

Faculty

K. Mariye Takahashi

Counselors

Velia Lawson

Therese Mosqueda-Ponce

Daniel Pelletier

PROGRAM LEARNING OUTCOMES (PLOs)

The courses taught by this department contribute to the General Education and Basic Skills Program Learning Outcomes. Please refer to General Education and Basic Skills Program Learning Outcomes.

Japanese (JAPN)

JAPN 098 C Japanese Seminar .5 to 12 Units

Prerequisite: May be required.
Corequisite: May be required.
Advisory: May be required.
 Term hours: 0–216 lecture and/or 0–432 laboratory depending on units attempted. This seminar is for students who wish to extend their knowledge of literature, language and culture through small group discussion. May be taken for credit 1–4 times. Pass/No Pass or Pass/No Pass/Letter Grade Option or Standard Letter Grade. Fees may be required — Payable at Registration.

JAPN 100 C Spoken Japanese for Beginners 3 Units

Term hours: 48–54 lecture. This course is for students who would like to take conversational Japanese without having to learn the complicated writing system. This will be an introduction to spoken Japanese, with emphasis on vocabulary development, use of the common phrases and culturally appropriate language at beginning levels. Conducted mainly in Japanese through the use of the direct teaching method. May be taken for credit 2 times. Pass/No Pass/Letter Grade Option. (CSU, AA GE)

JAPN 101 C Elementary Japanese I 5 Units

Term hours: 80–90 lecture. The course emphasizes the acquisition of basic skills in pronunciation, listening, speaking, reading and writing. Students will be introduced to the culture, history and geography of Japan through lectures, slides, videos, photographs, films, and reading assignments. Not intended for native Japanese speakers. Pass/No Pass/Letter Grade Option. (UC/CSU, AA GE, CSU GE)

JAPN 102 C Elementary Japanese II 5 Units

Prerequisite: JAPN 101 C with a grade of "C" or better or one year of high school Japanese with an average of "C" or better is recommended.
 Term hours: 80–90 lecture. The course continues to emphasize the acquisition of basic skills in pronunciation, listening, speaking, reading, and writing. Students will increase their knowledge of the culture, history, and geography of Japan and Japanese through lectures, films, and reading and writing assignments. Pass/No Pass/Letter Grade Option. (UC/CSU, AA GE, CSU GE, IGEC)

JAPN 125 C Japanese Culture through Film 3 Units

Term hours: 48–54 lecture. This course is a critical study of Japanese culture through viewing films of great directors. The student will study artistic works of internationally recognized principal directors and examine uniquely Japanese traits and critically analyze the identification of characters. The course will provide students with insights into Japanese culture and techniques for the critical analysis of film. Pass/No Pass/Letter Grade Option. (UC/CSU, AA GE, CSU GE)

JAPN 200 C Conversational Japanese 2 Units

Prerequisite: JAPN 102 C with a minimum grade of "C."

Term hours: 32–36 lecture. The course(s) will focus on practical conversation with emphasis on the idiomatic usage of the language. Topics concern Japanese life, culture, and current events. Students will prepare for this class through the study of the required textbook, magazines, newspapers and other current materials. The course is conducted in Japanese. May be taken for credit 4 times. Pass/No Pass/Letter Grade Option. (CSU, CSU GE)

JAPN 201 C Study of Kanji 3 Units

Prerequisite: JAPN 102 C.

Term hours: 48–54 lecture. This is a low intermediate skill course designed to improve the reading, writing, listening, and understanding of Kanji. Students will practice and learn 420 basic Kanji, as components of more complex Kanji. This will prepare students to take the Japanese government's proficiency examination at the 10th and 9th level. By repeating the class, students will be able to advance up to the 2nd level. Pass/No Pass/Letter Grade Option. (CSU)

JAPN 203 C Intermediate Japanese III 4 Units

Prerequisite: JAPN 102 C with a grade of "C" or better or two years of high school Japanese with an average grade of "C."

Term hours: 64–72 lecture. The course emphasizes the acquisition of advanced skills in listening, speaking, reading, and writing. Students will be introduced to further elements of the culture, history, and geography of Japan through lectures, slides, films, dialogues and reading assignments conducted in Japanese. Pass/No Pass/Letter Grade Option. (UC/CSU, AA GE, CSU GE, IGETC)

JAPN 204 C Intermediate Japanese IV 4 Units

Prerequisite: JAPN 203 C with a grade of "C" or better or three years of high school Japanese with an average grade of "C."

Course hours 64–72. The course emphasizes the acquisition of advanced skills in listening, speaking, reading, and writing. Students will be introduced to further elements of the culture, history, and geography of Japan through lectures, slides, films, dialogues and reading assignments conducted in Japanese. Pass/No Pass/Letter Grade Option. (UC/CSU, AA GE, CSU GE, IGETC)

JAPN 291 C Anime I: Study of Culture 3 Units

Term hours: 48–54 lecture. This course is a critical study of Japanese anime as culture. Students will discover how these films are created, from the point of view of technique and imagination. Students will practice critical ways of viewing the films. Students will also learn to see the films in their cultural context and as representations of Japanese culture. Pass/No Pass/Letter Grade Option. (CSU)

JAPN 292 C Anime II: Language in Films 3 Units

Prerequisite: JAPN 102 C or eligibility for JAPN 203 C.

Term hours: 48–54 lecture. This course is a critical study of Japanese anime as culture and language. Students will study the measurable timing of artistic translation techniques (including use of storyboards, cell and 3DCG) in the context of Japanese culture. This class will be conducted in Japanese. Pass/No Pass/Letter Grade Option. (CSU)

JAPN 293 C Anime III: Manga Culture in U.S. 3 Units

Prerequisite: JAPN 102 C with a minimum grade of "C."

Term hours: 48–54 lecture. This course is a study of Japanese anime language and culture. It provides students with experience in literary areas of Manga language and an opportunity to explore Kanji and Katakana through the practical way of reading Manga. Students will also learn to see Manga in the context of Japanese literature and culture. Pass/No Pass/Letter Grade Option. (CSU)

JAPN 294 C Anime IV: Literature and Culture 3 Units

Prerequisite: JAPN 102 C with a minimum grade of "C."

Term hours: 48–54 lecture. This course is a critical study of Japanese literature and culture through anime. The course introduces students to internationally well-known works of literary fiction, providing the students with an opportunity to enrich their lives and develop an appreciation of good Japanese literature and culture. Pass/No Pass/Letter Grade Option. (CSU)

JAPN 298 C Japanese Seminar .5 to 12 Units

Prerequisite: May be required.

Corequisite: May be required.

Advisory: May be required.

Term hours: 0–216 lecture and/or 0–432 laboratory depending on units attempted. This seminar is for students who wish to extend their knowledge of literature, language and culture through small group discussion. May be taken for credit 1–4 times. Pass/No Pass or Pass/No Pass/Letter Grade Option or Standard Letter Grade. Fees may be required — Payable at Registration. (UC Credit Limitation/CSU)

JAPN 299 C Japanese Independent Study .5 to 2 Units

Prerequisite: Approved Independent Study Learning Contract.

Term hours: 8–36 lecture/conference depending on units attempted. This course is for able students who wish to increase their knowledge of the Japanese language through individual study or research. Unit credit may range from .5–2 units in any given semester. May be taken for credit 3 times. Pass/No Pass/Letter Grade Option. (UC Credit Limitation/CSU)

JAPANESE TRANSFER PROGRAM

Students should consult a counselor or www.assist.org for lower division major requirements for most California public universities. (See the Standard Definitions section of the catalog for a description of ASSIST.) Students transferring to an independent college/university should consult the catalog of the individual school and a counselor for lower division major requirements.

Journalism/Communications

Division of Fine Arts

Division Dean — Ting-Pi (Joyce) Carrigan

Faculty

Robert Mercer

Counselors

Renay Laguana-Ferinac

Renee Ssensalo

PROGRAM LEARNING OUTCOMES (PLOs)

Program Learning Outcomes (PLOs) are in the process of finalization.

COMMUNICATIONS TRANSFER PROGRAM

Students should consult a counselor or www.assist.org for lower division major requirements for most California public universities. (See the Standard Definitions section of the catalog for a description of ASSIST.) Students transferring to any college/university should consult the catalog of the individual school and a counselor for lower division major requirements.

INTEGRATED JOURNALISM SKILLS

CERTIFICATE

Department Proficiency, Not State Approved

The Integrated Journalism Certificate displays the student understands the use of multimedia reporting. The student learns print, broadcast and online news gathering and production skills making the student qualified for entry-level internships and employment in most media.

To earn a certificate, complete the required courses as listed with a minimum grade of "C." At least 50% of all coursework must be completed at Cypress College.

Required courses are listed in suggested sequence:

Course #	Title	Units
JOUR 110 C	Global Media	3
JOUR 101 C	Reporting and Writing	3
MAD 181 C	Digital Video/Win	3
	or	
MAD 180 C	Digital Video/Mac	(3)
JOUR 299 C	Independent Study	2
Take two of the following courses:		
JOUR 225 C	Print Production	3
JOUR 226 C	Online Production	3
JOUR 228 C	Visualjournalism	3
JOUR 229 C	Broadcast Production	3
Total Units Required		17

INTERNATIONAL JOURNALISM SKILLS CERTIFICATE

Department Proficiency, Not State Approved

International Journalism prepares the student to work worldwide, either as a netizen of the worldwide web or as an international correspondent. The certificate capstone is two units of independent study in an international environment; preferably a study abroad program.

To earn a certificate, complete the required courses as listed with a minimum grade of "C." At least 50% of all coursework must be completed at Cypress College.

Required courses are listed in suggested sequence:

Course #	Title	Units
JOUR 110 C	Global Media	3
JOUR 101 C	Reporting and Writing	3
JOUR 226 C	Online Production	3
ENGL 110 C	Humanities: Ancient and Medieval	3
	or	
ENGL 111 C	Humanities: Renaissance–Present	(3)
HIST 112 C	World Civilizations I	3
	or	
HIST 113 C	World Civilizations II	(3)
JOUR 299 C	Independent Study	2
Total Units Required		17

Journalism/Communications (JOUR)

JOUR 101 C Reporting and Writing

3 Units

Term hours: 48–54 lecture. Students learn the fundamentals of reporting and writing for mass media, including print, radio, television, and the worldwide web. They learn news gathering strategies including interviewing using audio and video technology and computer assisted research. They learn Associated Press style news and feature writing, plus story formatting for print, radio and television scripting. (UC/CSU)

JOUR 110 C Global Media

3 Units

Term hours: 48–54 lecture. This course examines the histories, structures, functions, political, social, and economic impacts of the mass media and support systems, including legal and ethical issues. Study of newspapers, magazines, films, radio, television and internet, with an emphasis on evolving media models that may provide future careers for students. (UC/CSU, AA GE, CSU GE)

JOUR 118 C Messages for Electronic Media

3 Units

Term hours: 48–54 lecture. A speech and mass communications class that investigates the history, theory, contemporary issues, and current law in broadcasting, cable and the Web. Students create and broadcast video and audio presentations in addition to learning through lecture and reading. (CSU, CSU GE)

JOUR 140 C Public Relations and Publicity

3 Units

Advisory: Ability to type 20 words per minute and understand basic computer operation.

Term hours: 48–54 lecture. Students will study and practice the techniques and responsibilities of industrial, governmental, and civic public relations, with special attention to publicity writing and public relations campaign development. (CSU)

JOUR 225 C Print Production

3 Units

Advisory: Should be able to type 20 words per minute.

Term hours: 48–54 lecture. Students publish campus publications for the printing press. The course is taught in a media convergence newsroom in which students work alongside, and share their content with other student media. Skills developed included reporting, writing, and editing; desktop publishing; desktop editing of photographs and the creation of graphics; and digital photography; plus managing media and advertising. (CSU)

JOUR 226 C Online Production

3 Units

Advisory: Should be able to type 20 words per minute.

Term hours: 48–54 lecture. Emphasis is on creating and maintaining The Cypress Chronicle student news website, CyChron.com. The course is taught in a newsroom using the media convergence model in which students work alongside of, and share their production with, other campus media. Skills developed include writing for the internet, using digital photography, editing digital video and audio, using online publishing software, plus managing media and advertising. (CSU)

JOUR 228 C Visualjournalism**3 Units***Advisory: Should be able to type 20 words per minute.*

Term hours: 48–54 lecture. Emphasis is on creating visual stories using digital photography and/or videography. The student will plan, photograph or videograph, report, write, layout or edit visual story packages for the student campus media. Skills include digital photography and videography, reporting, writing, desktop photographic editing, desktop publishing, and video editing. (CSU)

JOUR 229 C Broadcast Production**3 Units***Advisory: Should be able to type 20 words per minute.*

Term hours: 48–54 lecture. Emphasis is on creating broadcast television and radio-style programming for posting as files and for streaming on the internet as well as for distributing conventionally. The course is taught in a newsroom using the media convergence model in which students work alongside of, and share their production with, other campus media. Skills developed include broadcast writing, videography, audio and video production, and internet distribution, plus managing media and advertising. (CSU)

JOUR 230 C Video for Photographers**3 Units***Prerequisite: Completion of or concurrent enrollment in PHOT 101 C with a minimum grade of "C."*

Term hours: 48–54 lecture. Video for Photographers introduces the photographer to the use of a single device — a digital camcorder with frame capture or a digital camera with high-definition video, or a hybrid device — for simultaneous video and still imaging. The student learns single-camera and three-camera production techniques on location and in the studio. The course includes using the still camera motor drive as a digital video tool. The student's project will include: Treatments, scripts, shooting scripts, shooting video, shooting sequential photographs, basic audio, logging, edit decision lists, frame capture, video editing software, slideshow production, and presentation in a multimedia presentation platforms. This course gives basic video skills to the photographer who must work in video, also, for multimedia. (CSU)

JOUR 298 C Communication/Journalism Seminar**.5 to 12 Units***Prerequisite: May be required.**Corequisite: May be required.**Advisory: May be required.*

Term hours: 0–216 lecture and/or 0–648 laboratory depending on units attempted. This seminar is for able students who wish to extend their knowledge of literature, language and culture through small group discussion. Fees may be required — Payable at Registration. May be taken for credit 4 times. Pass/No Pass or Pass/No Pass/Letter Grade Option or Standard Letter Grade. (UC Credit Limitation/CSU)

JOUR 299 C Communications/Journalism Independent Study**.5 to 2 Units***Prerequisite: Approved Independent Study Learning Contract.*

Term hours: 0–36 lecture and/or 0–108 laboratory depending on units attempted. Students enroll who wish to increase their knowledge of journalism through individual study, research or internships. Permission of the instructor is required along with a contract outlining a student's independent work and the supervision of the instructor. May be taken for credit 4 times. (CSU)

Latin American Studies

LATIN AMERICAN STUDIES TRANSFER PROGRAM

Students should consult a counselor or www.assist.org for lower division major requirements for most California public universities. (See the Standard Definitions section of the catalog for a description of ASSIST.) Students transferring to an independent college/university should consult the catalog of the individual school and a counselor for lower division major requirements.

Law Enforcement — See Administration of Justice (AJ)

Liberal Studies

GENERAL LIBERAL STUDIES**TRANSFER PROGRAM**

Students should consult a counselor or www.assist.org for lower division major requirements for most California public universities. (See the Standard Definitions section of the catalog for a description of ASSIST.) Students transferring to an independent college/university should consult the catalog of the individual school and a counselor for lower division major requirements.

Multiple Subject Matter Program

A Multiple Subject Credential is required to teach elementary school in California. Before entering a Multiple Subject Credential Program a student must either earn a Bachelor Degree and pass the Multiple Subjects Assessment for Teachers or complete a Bachelor Degree that includes an approved Multiple Subject Matter Program that meets the seven areas prescribed by the Commission on Teacher Credentialing. Students should see a counselor for assistance in choosing appropriate classes to meet specific university requirements.

NOTE: Students interested in Liberal Arts (Teacher Preparation, please see listing under Teaching).

Learning and Academic Resources

Division of Library and Learning Resource Centers

Interim Division Dean — Eldon Young

Learning and Academic Resources (LAR)

LAR 010 C Improving Individual Skills 0 Units

Term hours: 6–72 hours. This course provides individualized units of study based on individual student needs, which may involve improvement in writing, reading, or mathematic skills. Non-Credit Course. Pass/No Pass/Letter Grade Option.

LAR 020 C Improving Individual ESL Skills 0 Units

Term hours: 6–72. This course provides individualized units of study based on individual ESL student needs, which may involve improvement in writing, reading, listening, or speaking skills. Non Credit Course. Pass/No Pass/Letter Grade Option.

LAR 100 C Tutoring Techniques 1 Unit

Term hours: 16–18 lecture. This course provides preparation and training for successful tutoring and study group leadership in multiple subject areas. Instruction will focus on tutoring principles, specific tutoring techniques, collaborative learning strategies, study skills, and communication skills. This course is strongly recommended for both students who wish to tutor on campus and students interested in careers in education. Pass/No Pass/Letter Grade Option. (CSU)

Library

Division of Library and Learning Resource Centers

Interim Division Dean — Eldon Young

Faculty

Peggy Austin
Monica Doman
William Pashaie
Joyce Peacock

Counselors

Velia Lawson
Therese Mosqueda-Ponce
Daniel Pelletier

Library (LIB)

LIB 100 C Introduction to Research 1 Unit

Term hours: 16–18 lecture. This class is designed to introduce students to traditional and electronic library research tools and resources including the Internet. Students learn how to develop research strategies that will enable them to locate, retrieve, analyze, evaluate, and cite appropriate resources on a given topic. Each student will compile and prepare a written bibliography of relevant sources on a topic. Pass/No Pass/Letter Grade Option. (UC/CSU)

Management

Division of Business and Computer Information Systems

Division Dean — Dave Wassenaar

Faculty

Patricia Kishel

Counselor

Robert Grantham

PROGRAM LEARNING OUTCOMES (PLOs)

Management

A student who completes the management field of study will be able to:

- Understand how organizations operate and what it takes to succeed as a manager, acquiring the leadership knowledge and skills to carry out administrative functions in the key areas of management, communications, finance, and law.
- Enhance his/her employment opportunity in the specific area of management.

ASSOCIATE IN ARTS DEGREE BUSINESS

Program Code: 1A16599

This curriculum is designed to provide an opportunity for the business major to achieve an Associate in Arts Degree Business Administration while completing the first and second year requirements for transfer to a four-year institution. While a baccalaureate degree is recommended preparation for those considering professional careers in business administration, completion of this curriculum will demonstrate commitment to the field and provide comprehensive preparation for upper-division work.

Students should consult a counselor and the catalog of the individual college or university to plan a program of study. The Internet site www.assist.org will also provide information for California public universities. Courses selected to fulfill the requirements of the associate degree should reflect requirements of the college to which the student plans to transfer.

To earn an Associate Degree students must complete: (1) all major course requirements with a minimum grade of “C”; (2) California State University General Education Breadth requirements (CSU GE Breadth) or IGETC General Education Plan; (3) any elective courses to complete a minimum of 60 units; (4) complete all graduation requirements; and, (5) have an overall GPA of 2.0. At least 50% of all major course work must be completed at Cypress College. **Students pursuing more than one specified departmental major may double count a maximum of 7 units to fulfill major requirements.**

Courses that fulfill major requirements for an Associate Degree at Cypress College might not be the same as those required for completing the major at a transfer institution offering a Baccalaureate Degree. For information on specific university requirements, please consult with your counselor, or visit the Transfer Center.

Required courses are listed in suggested sequence:

Course #	Title	Units
MGT 161 C	Introduction to Business	3
CIS 111 C	Computer Information Systems	3
*ECON 100 C	Principles of Economics — Macro or	3
*ECON 100HC	Honors Principles of Economics	(3)
**ECON 105 C	Principles of Economics — Micro or	3
**ECON 105HC	Honors Principles of Economics	(3)
MGT 240 C	Legal Environment of Business or	3
MGT 241 C	Legal Aspects — Business Transactions	(3)
ACCT 101 C	Financial Accounting	4
ACCT 102 C	Managerial Accounting	4
MATH 130 C	Survey of Calculus	4
MKT 222 C	Principles of Marketing	3
Total Units Required		30

Elective:

MGT 211 C	Writing for Business	3
-----------	----------------------	---

*A score of 3 or higher on the Advanced Placement (AP) Economics (macro) exam meets this requirement upon petition through Admissions and Records. See a counselor for more information.

**A score of 3 or higher on the Advanced Placement (AP) Economics (micro) exam meets this requirement upon petition through Admissions and Records. See a counselor for more information.

ASSOCIATE IN SCIENCE DEGREE**BUSINESS MANAGEMENT Program Code: 1S03762**

This curriculum is designed to prepare students for careers in the administration of modern organizations. Focusing on the ways that businesses operate and what it takes to succeed as a manager, the program covers such areas as management, marketing, law, accounting, economics, and the global environment.

To earn an Associate Degree students must complete: (1) all major course requirements with a minimum grade of "C"; (2) 25 units of General Education Graduation Requirements; (3) the cultural diversity and reading requirements; (4) any elective courses to complete a minimum of 60 units; and, (5) have a minimum GPA of 2.0. At least 50% of all major course work must be completed at Cypress College.

Courses that fulfill major requirements for an Associate Degree at Cypress College might not be the same as those required for completing the major at a transfer institution offering a Baccalaureate Degree. For information on specific university requirements, please consult with your counselor, or visit the Transfer Center.

Required courses are listed in suggested sequence:

Course #	Title	Units
MGT 161 C	Introduction to Business	3
CIS 111 C	Computer Information Systems	3
MGT 262 C	Principles of Management	3
MGT 266 C	Human Relations in Business	3
MGT 240 C	Legal Environment of Business or	3
MGT 241 C	Legal Aspects — Business Transactions	(3)
ACCT 101 C	Financial Accounting	4
MKT 222 C	Principles of Marketing	3
ECON 110 C	Survey of Economics or	3
**ECON 105 C	Principles of Economics — Micro or	(3)
**ECON 105HC	Honors Principles of Economics	(3)
MGT 261 C	Small Business Management	3
Total Units Required		28

Electives

MKT 205 C	Multicultural Markets in U.S.	3
MKT 208 C	Principles of Selling	3
MGT 151 C	Business Mathematics	3
ACCT 102 C	Managerial Accounting	4
MGT 111 C	Business Communications	3
MGT 269 C	Office Management	3
MGT 265 C	Social Responsibility of Business	3

**A score of 3 or higher on the Advanced Placement (AP) Economics (micro) exam meets this requirement upon petition through Admissions and Records. See a counselor for more information.

**MANAGEMENT
CERTIFICATE****Program Code: 1C21095**

Primary emphasis is to provide students with the necessary skills to perform the various administrative duties of a manager. The program focuses on management, marketing, law, accounting, economics, and the global environment.

To earn a certificate, students must complete the required courses as listed with a minimum grade of "C." At least 50% of all course work must be completed at Cypress College.

Required courses are listed in suggested sequence:

Course #	Title	Units
MGT 161 C	Introduction to Business	3
CIS 111 C	Computer Information Systems	3
MGT 261 C	Small Business Management	3
MGT 266 C	Human Relations in Business	3
ACCT 101 C	Financial Accounting	4
ECON 110 C	Survey of Economics or	3
**ECON 105 C	Principles of Economics — Micro or	(3)
**ECON 105HC	Honors Principles of Economics	(3)
MGT 240 C	Legal Environment of Business or	3
MGT 241 C	Legal Aspects — Business Transactions	(3)
MGT 262 C	Principles of Management	3
MKT 222 C	Principles of Marketing	3
Total Units Required		28

**A score of 3 or higher on the Advanced Placement (AP) Economics (micro) exam meets this requirement upon petition through Admissions and Records. See a counselor for more information.

**ASSOCIATE IN SCIENCE DEGREE
RETAIL MANAGEMENT Program Code: 1S12307**

This curriculum is designed to prepare students to assume leadership positions in the retail sector, providing them with the essential business skills needed to perform supervisory and management duties. Created through a partnership with the Western Association of Food Chains and retailers in a variety of fields, this program will help students pursue careers in the grocery industry and others that deal directly with consumers, such as the apparel, home furnishings, general merchandise, and services industries.

To earn an Associate Degree students must complete: (1) all major course requirements with a minimum grade of "C"; (2) 25 units of General Education Graduation Requirements; (3) the cultural diversity and reading requirements; (4) any elective courses to complete a minimum of 60 units; and, (5) have a minimum GPA of 2.0. At least 50% of all major course work must be completed at Cypress College.

Courses that fulfill major requirements for an Associate Degree at Cypress College might not be the same as those required for completing the major at a transfer institution offering a Baccalaureate Degree. For information on specific university requirements, please consult with your counselor, or visit the Transfer Center.

Required courses are listed in suggested sequence:

Course #	Title	Units
MGT 111 C	Business Communications	3
	or	
MGT 211 C	Writing for Business	(3)
MGT 151 C	Business Mathematics	3
CIS 111 C	Computer Information Systems	3
COMM 100 C	Human Communication	3
	or	
COMM 100HC	Honors Human Communication	(3)
MGT 262 C	Principles of Management	3
ACCT 101 C	Financial Accounting	4
MKT 222 C	Principles of Marketing	3
MKT 105 C	Principles of Retailing	3
MGT 266 C	Human Relations in Business	3
MGT 268 C	Human Resources Management	3
Total Units Required		31

**RETAIL MANAGEMENT
CERTIFICATE Program Code: 1C03762**

Primary emphasis is to provide students with the essential business skills needed to develop a successful management career in retailing. Created through a partnership with the Western Association of Food Chains and retailers in a variety of fields, this certificate will help prepare students to work in the grocery industry and others that deal directly with consumers, such as the apparel, home furnishings, general merchandise, and services industries.

To earn a certificate, students must complete the required courses as listed with a minimum grade of "C." At least 50% of all course work must be completed at Cypress College.

Required courses are listed in suggested sequence:

Course #	Title	Units
MGT 111 C	Business Communications	3
	or	
MGT 211 C	Writing for Business	(3)
MGT 151 C	Business Mathematics	3
CIS 111 C	Computer Information Systems	3
COMM 100 C	Human Communication	3
	or	
COMM 100HC	Honors Human Communication	(3)
MGT 262 C	Principles of Management	3
ACCT 101 C	Financial Accounting	4
MKT 222 C	Principles of Marketing	3
MKT 105 C	Principles of Retailing	3
MGT 266 C	Human Relations in Business	3
MGT 268 C	Human Resources Management	3
Total Units Required		31

**ASSOCIATE IN SCIENCE DEGREE
SMALL BUSINESS
MANAGEMENT Program Code: 1S12296**

This curriculum is designed to provide students with the necessary information and skills to start, manage, and promote a small business enterprise in today's global environment. Focusing on the steps involved in building a business, the program covers all aspects of business ownership and the ways to develop one's entrepreneurial abilities.

To earn an Associate Degree students must complete: (1) all major course requirements with a minimum grade of "C"; (2) 25 units of General Education Graduation Requirements; (3) the cultural diversity reading requirements; (4) any elective courses to complete a minimum of 60 units; and, (5) have a minimum GPA of 2.0. At least 50% of all major course work must be completed at Cypress College.

Courses that fulfill major requirements for an Associate Degree at Cypress College might not be the same as those required for completing the major at a transfer institution offering a Baccalaureate Degree. For information on specific university requirements, please consult with your counselor, or visit the Transfer Center.

Required courses are listed in suggested sequence:

Course #	Title	Units
MGT 161 C	Introduction to Business	3
MGT 261 C	Small Business Management	3
MKT 201 C	Small Business Promotion	3
MKT 222 C	Principles of Marketing	3
MKT 208 C	Principles of Selling	3
MGT 266 C	Human Relations in Business	3
ACCT 101 C	Financial Accounting	4
Select a minimum of 6 units from the elective courses listed below		6
Total Units Required		28

Electives

MKT 103 C	Principles of Advertising	3
CIS 111 C	Computer Information Systems	3
MKT 224 C	International Marketing	3
MGT 101 C	Personal Finance	3
MKT 105 C	Principles of Retailing	3
MGT 267 C	Principles of Supervision	3
MGT 211 C	Writing for Business	3

SMALL BUSINESS MANAGEMENT**CERTIFICATE****Program Code: 1C00013**

Primary emphasis is to provide an organized course of study that will enable students to develop their entrepreneurial skills, recognize opportunities, and learn the basics of starting and managing a small business in today's global environment.

To earn a certificate, students must complete the required courses as listed with a minimum grade of "C." At least 50% of all course work must be completed at Cypress College.

Required courses are listed in suggested sequence:

Course #	Title	Units
MGT 161 C	Introduction to Business	3
MGT 261 C	Small Business Management	3
MKT 201 C	Small Business Promotion	3
MKT 222 C	Principles of Marketing	3
MKT 208 C	Principles of Selling	3
MGT 266 C	Human Relations in Business	3
ACCT 101 C	Financial Accounting	4
Select a minimum of 6 units from the elective courses listed below		6
Total Units Required		28

Electives

MKT 103 C	Principles of Advertising	3
CIS 111 C	Computer Information Systems	3
MKT 224 C	International Marketing	3
MGT 101 C	Personal Finance	3
MKT 105 C	Principles of Retailing	3
MGT 267 C	Principles of Supervision	3
MGT 211 C	Writing for Business	3

BUSINESS ECONOMICS**CERTIFICATE****Program Code: 1K17172**

Combining economics principles with business practices, this certificate program provides students with the necessary knowledge to make informed financial decisions. Students will gain an understanding of supply and demand and resource allocation issues, marketplace competitive factors, consumer purchasing patterns, and money-management and investment strategies.

To earn a certificate, students must complete the required courses as listed with a minimum grade of "C." At least 50% of all course work must be completed at Cypress College.

Required courses are listed in suggested sequence:

Course #	Title	Units
**ECON 105 C	Principles of Economics — Micro or	3
**ECON 105HC	Honors Principles of Economics	(3)
MGT 161 C	Introduction to Business	3
ECON 130 C	Consumer Economics or	3
MKT 210 C	Consumer Behavior	(3)
MGT 101 C	Personal Finance or	3
MGT 102 C	Financial Literacy	(3)
Total Units Required		12

**A score of 3 or higher on the Advanced Placement (AP) Economics (micro) exam meets this requirement upon petition through Admissions and Records. See a counselor for more information.

CALL CENTER OPERATIONS SKILLS**CERTIFICATE****Program Code: 1K00551**

This certificate is designed for individuals who are currently employed by or wish to work in organizations that utilize call centers. Created in partnership with the Automobile Club of Southern California, Mitsubishi Motors North America, Inc., PacifiCare, Toyota, and others, the program trains students to work in such settings as credit collection, customer service, insurance claims processing, inside sales, and other call center environments. The primary emphasis of this certificate is to prepare the student for occupational competency. It focuses on developing human relations, communication, computer, and other required skills. Enabling students to function successfully in the call center environment, the certificate also lays the foundation for moving into management or supervisory positions. Many of the classes can be applied to the Associate in Science Degree Management.

To earn a certificate, complete the required courses as listed with a minimum grade of "C." At least 50% of all course work must be completed at Cypress College.

Required courses are listed in suggested sequence:

Course #	Title	Units
MGT 111 C	Business Communications or	3
MGT 211 C	Writing for Business	(3)
MGT 266 C	Human Relations in Business	3
MGT 151 C	Business Mathematics	3
CIS 111 C	Computer Information Systems or	3
CIS 116 C	MS Outlook/Office Procedures	(3)

Select one course from the following:

Course #	Title	Units
MGT 240 C	Legal Environment of Business or	3
MGT 241 C	Legal Aspects — Business Transactions	(3)
HS 145 C	Survey of Medical Terminology	(3)

Total Units 15**COMMERCIAL MUSIC — MANAGEMENT SKILLS****CERTIFICATE****Program Code: 1K12951**

A synthesis of Music and Business courses, this certificate enables students to develop the management, marketing, and entrepreneurial skills necessary for success in the Music Industry.

To earn a certificate, students must complete the required courses as listed with a minimum grade of "C." At least 50% of all course work must be completed at Cypress College.

Required courses are listed in suggested sequence:

Course #	Title	Units
MUS 111 C	The Music Business	3
MUS 212 C	Music Promotion and Distribution	3
MKT 222 C	Principles of Marketing	3
MGT 261 C	Small Business Management	3
MGT 266 C	Human Relations in Business or	3
MUS 117 C	American Popular Music	(3)
Total Units Required		15

Recommended Electives

CIS 111 C	Computer Information Systems	(3)
MKT 224 C	International Marketing	(3)
MUS 055 C	Music Work Experience	(1)

PROFESSIONAL MARKETING CERTIFICATE

Program Code: 1C31328

This certificate program provides students with a working knowledge of the marketing and sales activities required to satisfy customers' needs and wants for goods and services. Program is designed for both marketing and sales professionals and those wishing to pursue marketing careers. To earn a certificate, complete the required courses as listed with a minimum grade of "C." At least 50% of all course work must be completed at Cypress College.

Required courses are listed in suggested sequence:

Course #	Title	Units
MKT 090 C	Marketing Essentials	1
MKT 091 C	Advertising and Public Relations	1
MKT 092 C	Personal Selling	1
MKT 093 C	Target Marketing	.5
MKT 094 C	Buyer Behavior	.5
MKT 095 C	Market Distribution Systems	.5
MKT 096 C	Sales Promotion Techniques	.5
MKT 097 C	Customer Relations	.5
MKT 098 C	International Marketing — Small Business	.5
MKT 086 C	Sales Prospecting	.5
MKT 087 C	Sales Presentations	.5
MKT 088 C	Handling Sales Objections	.5
MKT 089 C	Making the Sale	.5
MGT 085 C	Business Planning	1
MGT 161 C	Introduction to Business	3
Total Units		12

SMALL BUSINESS OPERATIONS CERTIFICATE

Program Code: 1C31342

This certificate program provides students with information on the various steps and management and marketing decisions involved in starting and operating a business. Program is designed for both prospective and current business owners.

To earn a certificate, students must complete the required courses as listed with a minimum grade of "C." At least 50% of all course work must be completed at Cypress College.

Required courses are listed in suggested sequence:

Course #	Title	Units
MGT 085 C	Business Planning	1
MGT 086 C	Business Finance — Recordkeeping	.5
MGT 087 C	Obtaining and Using Computers	.5
MGT 088 C	Managing Personnel	.5
MGT 089 C	Business Law — Small Business	.5
MKT 090 C	Marketing Essentials	1
MKT 091 C	Advertising and Public Relations	1
MKT 092 C	Personal Selling	1
MKT 093 C	Target Marketing	.5
MKT 094 C	Buyer Behavior	.5
MKT 095 C	Market Distribution Systems	.5
MKT 096 C	Sales Promotion Techniques	.5
MKT 097 C	Customer Relations	.5
MKT 098 C	International Marketing — Small Business	.5
MGT 161 C	Introduction to Business	3
Total Units		12

MANAGEMENT TRANSFER PROGRAM

Refer to Catalog under:

BUSINESS ADMINISTRATION TRANSFER PROGRAM

Students should consult a counselor or www.assist.org for lower division major requirements for most California public universities. (See the Standard Definitions section of the catalog for a description of ASSIST.) Students transferring to an independent college/university should consult the catalog of the individual school and a counselor for lower division major requirements.

Management (MGT)

CONSUMER RELATIONS

MGT 101 C Personal Finance

3 Units

Term hours: 48–54 lecture. This course encourages the management of personal income and expenses through effective financial planning, budgeting, and investing. By utilizing these tools in a contemporary manner, students will discover opportunities for a much improved standard of living. The topics explored include wealth building, smart consumer purchasing, goal setting, risk taking, tax deferred investing, and credit cards. Pass/No Pass/Letter Grade Option. (CSU)

ENGLISH-RELATED COURSES

MGT 055 C Business English

3 Units

Term hours: 48–54 lecture. This course includes instruction in techniques of basic grammar, punctuation, vocabulary, spelling, and capitalization. The emphasis is on grammar as used in business communications.

MGT 111 C Business Communications

3 Units

Prerequisite: MGT 055 C.

Term hours: 48–54 lecture. The course includes instruction in the techniques of specific types of business communication media and in the general principles of effective communication. The elements and principles of written and spoken communications are covered with emphasis on the kind of writing and speaking that is conducted throughout a business career. The importance of communication is stressed. Applying skill and ingenuity in the use of the language is encouraged. Credit by Examination. (CSU)

MGT 211 C Writing for Business

3 Units

Prerequisite: ENGL 100 C with a grade of "C" or better.

Term hours: 48–54 lecture. This course is an introduction to communication skills and knowledge needed in organizations. This course will include communication fundamentals, ethical, legal, multicultural issues, correspondence applications, employment communication, oral and non-verbal communication, report writing, management presentations, research methods, and running effective meetings and conferences. Computer applications will be presented throughout the course. (CSU)

MATH-RELATED COURSES

MGT 051 C Basic Business Mathematics

3 Units

Term hours: 48–54 lecture. This course is a review of the fundamentals of arithmetic with special emphasis given to the solution of problems involving decimals, interest, and business operations. Drills are provided to improve speed and accuracy. This course is recommended for all students majoring in business who lack proficiency in basic mathematics as determined by examination.

MGT 151 C Business Mathematics **3 Units**
Term hours: 48–54 lecture. This course is an introduction to the fundamental operation of arithmetic as applied to business problems. Included are problems in simple and compound interest; bank and purchase discounts, payroll computations, sales and property taxes, depreciation, business financial statements, and distribution of ownership and profits. (CSU, AA GE)

**ORGANIZATION/PERSONNEL/
MANAGEMENT-RELATED COURSES**

MGT 061 C Survey of Business **3 Units**
Term hours: 48–54 lecture. This course provides a practical overview of business and how it applies to personal growth and success. The areas of study include inflation, social awareness, the stock market, communications, marketing, self-management, human relations, business problems, and future careers. Informal groups, gaming, personal workshop activities, and positive imagery will be utilized. Pass/No Pass/Letter Grade Option.

MGT 075 C Basic Keyboarding Tech and Term **.5 Units**
Term hours: 8–9 lecture and 8–9 laboratory. This course is designed for potential managers or people of all professions who need to become familiar with keyboarding (typing on information system workstations or typewriters) for easier and more proficient use of workstations. This course provides basic keyboarding skills and a working knowledge of terminology for the use of information system workstations to access, manipulate, and communicate for better management of information. It is designed for non-secretarial or non-clerical majors.

MGT 085 C Business Planning **1 Unit**
Term hours: 16–18 lecture. This course is designed for both prospective and current entrepreneurs. It focuses on the steps involved in starting a business, including choosing the type of business and location, financial and legal considerations, marketing and management strategies. Participants will receive guidance on preparing a complete business plan. Pass/No Pass only.

MGT 086 C Business Finance — Recordkeeping **.5 Units**
Term hours: 8–9 lecture. This course addresses financial start-up considerations, sources and uses of capital, bookkeeping and financial statements, as well as tax reporting requirements. Pass/No Pass only.

MGT 087 C Obtaining and Using Computers **.5 Units**
Term hours: 8–9 lecture. This course points out the factors to consider in buying computer equipment and software for a small business and examines the various business functions that computers can perform. Pass/No Pass only.

MGT 088 C Managing Personnel **.5 Units**
Term hours: 8–9 lecture. This course focuses on techniques for the recruitment, training, compensation, management and motivation of workers in the business enterprise. Pass/No Pass only.

MGT 089 C Business Law — Small Business **.5 Units**
Term hours: 8–9 lecture. This course covers topics including choosing the proper legal form, licenses and permits, contracts, liability issues, and government regulations pertaining to business. Pass/No Pass only.

MGT 102 C Financial Literacy **3 Units**
Term hours: 48–54 lecture. This course is designed to provide students with the general financial knowledge and skills needed to take responsibility for their economic security. Enabling students to make informed decisions to manage their money, build wealth, and protect assets, it covers such topics as: income sources, saving and investing, spending and credit, consumer behavior and customer education, taxation, and the legal, social and political environment of finance. Pass/No Pass/Letter Grade Option. (CSU)

MGT 161 C Introduction to Business **3 Units**
Term hours: 48–54 lecture. This course provides a student-centered perspective covering a survey of principles and practices of international and American businesses. Subject areas include business organizations, marketing, finance, management, small business operations, and human dynamics. Pass/No Pass/Letter Grade Option. (UC/CSU, AA GE, CSU GE)

MGT 199 C Management Independent Study **.5 to 2 Units**
Prerequisite: Approved Independent Study Learning Contract.

Term hours: The number of hours of scheduled conferences or activity per week will be determined by the instructor. This course is designed for students who wish to gain experience in management activities or to increase knowledge and experience in applied areas of leadership. Students must obtain permission from instructor of subject area they will be working with and will be under direct supervision of that instructor. This course does not meet requirements of management classes. May be taken for credit 4 times. (CSU)

MGT 261 C Small Business Management **3 Units**
Term hours: 48–54 lecture. This course applies principles of management to small business enterprises. The major areas of study include planning, financial problems, organization, personnel relations, marketing decisions, location decisions, and franchising. Pass/No Pass/Letter Grade Option. (CSU)

MGT 262 C Principles of Management **3 Units**
Term hours: 48–54 lecture. This course focuses on the interrelationships of management decisions and the steps involved in the management process. The major areas of study include the basic management functions of planning, organizing, staffing, directing, and controlling work activities. Pass/No Pass/Letter Grade Option. (CSU)

MGT 265 C Social Responsibility of Bus. **3 Units**
Term hours: 48–54 lecture. This course addresses the social rather than the economic aspects of business responsibility. It considers the structure of business as it affects social responsiveness and accountability in its contribution to the quality of life. It stresses the need of business to develop closer relations with the community, educational, and business leaders as participants and speakers. Pass/No Pass/Letter Grade Option. (CSU)

MGT 266 C Human Relations in Business **3 Units**
Term hours: 48–54 lecture. This course provides an introduction to the principles of human behavior in modern organizations. The emphasis is placed on leadership theory, problems in communication, motivation, and the development of a productive work environment. Pass/No Pass/Letter Grade Option. (CSU, AA GE)

MGT 267 C Principles of Supervision **3 Units**
Term hours: 48–54 lecture. This course presents the fundamental techniques a supervisor needs to know about motivating people, managing a job, and the development of situational leadership styles. (CSU)

MGT 268 C Human Resources Management **3 Units**
Term hours: 48–54 lecture. This course provides theories and practices relating to personal administration, labor-management relations, employee selection, training, performance appraisal, discharge, hours of work and methods of payment, handling of personnel problems, benefit programs, affirmative action, and equal employment. (CSU)

MGT 269 C Office Management **3 Units**
Term hours: 48–54 lecture. This course is a study of the problems involved in the organization and management of a business office. The major problems identified and characterized in this course are the impact of automation upon the office manager's job, organizing and planning office work, controlling the people, the forms and the machines that do the work, creating proper human relations by effective supervision, modern personnel practices, employer-employee communications, and analyzing word processing as a method of paperwork cost reduction. (CSU)

MGT 295 C Management Internship 1 to 4 Units

Term hours: This course is designed to give the student credit for work experience at a related occupational worksite, while being concurrently enrolled in a vocational major. For each unit of credit, a minimum of 75 paid or 60 unpaid worksite internship hours is required. The internship allows students to apply knowledge gained in college courses to an actual work setting, sample career choices and improve job-readiness skills. Supplemental reading and course assignments required. May be taken for credit 4 times. Open Entry/Open Exit. Pass/No Pass/Letter Grade Option. (CSU)

MGT 298 C Management Seminar .5 to 12 Units

Prerequisite: May be required.

Corequisite: May be required.

Advisory: May be required.

Term hours: 0–216 lecture and/or 0–432 laboratory depending on units attempted. This course provides a lecture/discussion approach to particular problems for students who wish to increase their knowledge of business-related subjects not ordinarily covered in curriculum courses. Fees may be required — Payable at Registration. May be taken for credit 1–4 times. Pass/No Pass or Pass/No Pass/Letter Grade Option or Standard Letter Grade. (CSU)

LAW-RELATED COURSES**MGT 041 C Survey of Business Law 3 Units**

Term hours: 48–54 lecture. This course provides a survey of the basic principles of law that apply to business and personal transactions with emphasis given to the substantive law of torts, crimes, contracts, sales, bailments, commercial paper, agency, employment and labor relations, partnerships, corporations, insurance, secured transactions, real property, estates and trusts, and bankruptcy. Other areas of study include the nature and sources of law, the judicial system, domestic relations law, and government regulation of business. Pass/No Pass/Letter Grade Option.

MGT 141 C Personal Law 3 Units

Term hours: 48–54 lecture. This course provides a survey of the basic principles of law that affect the citizens in American society with consideration given to the nature and sources of law, the state and federal judicial system, lawyers, crimes, and torts. The areas of law studied relate to the citizen's role as family member, student, consumer, insured, tenant, landlord, homeowner, saver, investor, owner of motor vehicle, employee, employer, and estate planner. Pass/No Pass/Letter Grade Option. (CSU)

MGT 143 C Introduction to Legal Research 1 Unit

Term hours: 48–54 lecture. This course provides an introduction to the nature and use of legal reference material with consideration given to a uniform system of citation. An exposure to legal reference material will include constitutions, statutes and codes, executive orders, administrative agency regulations and rulings, treaties, judicial reports, indexes, digests, citators, treatises, looseleaf services, periodicals, encyclopedias, procedure manuals, and form books. Pass/No Pass/Letter Grade Option. (CSU)

MGT 240 C Legal Environment of Business 3 Units

Term hours: 48–54 lecture. This course is an introduction to the legal environment in which a business firm operates. Topics include an introduction to the American legal system, contracts, torts, product liability, forms of business organization, trade regulation, labor law, environmental law, and international business law. Pass/No Pass/Letter Grade Option. (UC Credit Limitation/CSU)

MGT 241 C Legal Aspects — Business Transactions 3 Units

Term hours: 48–54 lecture. This course is an introduction to business law principles and cases, including a review of the classes and sources of law, agencies for enforcement, court procedure, and civil and criminal liability. The major subject area studied incorporates a concentrated study of the law of contracts. A special study is made of sales of goods based upon the Uniform Commercial Code with emphasis placed on consumer protection. Pass/No Pass/Letter Grade Option. (UC Credit Limitation/CSU)

MGT 242 C American Judicial System 4 Units

Term hours: 64–72 lecture. This course provides an introduction to the basic principles of procedural law and the nature of the American judicial system with consideration given to an analysis of the decision making that takes place within the civil, criminal, and administrative agency processes. The areas of procedural law studied include the organization and jurisdiction of the courts, civil and criminal pretrial proceedings, discovery and production of evidence, trial practice, and appellate procedures. Pass/No Pass/Letter Grade Option. (CSU)

Marine Service Technician

Division of Career Technical Education

Division Dean — Steve Donley

Counselor

Jane Jepson

Marine Service (MRN)

MRN 060 C Diesel Engines 6 Units

Term hours: 48–54 lecture and 144–162 laboratory. This is a comprehensive study of light diesel engines as used in passenger cars, light marine propulsion applications (power and sailboats), stationary and auxiliary power plants (generators). The course includes servicing, overhaul, troubleshooting and diagnosis of the diesel engine and auxiliary systems. Practical application will be both laboratory engines and/or live diesel engines.

MRN 061 C Outboard Engine Repair/Service and Maintenance 6 Units

Term hours: 48–54 lecture and 144–162 laboratory. This course will cover the complete operating principles, theory and design features of outboard engines. The course will cover the repair, service, maintenance, overhaul and diagnosis of outboard engines such as Mercury, Johnson, and Evinrude. Students will be instructed using lecture/demonstrations and will perform various procedures in a simulated industrial laboratory. Practical experiences will be done on both laboratory units and live projects.

MRN 062 C Marine Drive Systems for Recreational Boats 4 Units

Term hours: 32–36 lecture and 96–108 laboratory. This course will cover the operating principles, theory and design features of marine drive systems for recreational boats (stern drives, jet drives, V drives and hydraulic and manual transmission). This course will cover the repair, service, maintenance, overhaul and diagnosis of stern drives, jet drives and inboard transmission systems such as OMC, Mercruiser, Volvo Penta, Panther jet, Berkeley jet, Jacuzzi jet and Borg Warner. Students will perform various procedures in a simulated industry laboratory environment, using both laboratory units and live projects.

MRN 064 C Outboard and Stern Drive Repair 4 Units

Term hours: 32–36 lecture and 96–108 laboratory. This course is designed to provide the student with advanced experiences in all areas of marine service technology. Students will be working on actual repair projects on outboard engines such as Johnson, Evinrude, Mercury, Yamaha. Stern drives such as Mercruiser, Volvo Penta, OMC, as well as inboards and jet drives will be covered.

MRN 298 C Marine Service Seminar .5 to 12 Units

Prerequisite: May be required.

Corequisite: May be required.

Advisory: May be required.

Term hours: 0–216 lecture and 0–648 laboratory depending on units attempted. This is a course for students who wish to increase their knowledge of marine service. Various topics will be offered. Unit credit may range from .5 to 12 units in any given semester. Consult the class schedule to verify credit for a particular semester. May be taken for credit 1–4 times. Pass/No Pass or Pass/No Pass/Letter Grade Option or Standard Letter Grade Option. Fees may be required — Payable at Registration. (CSU)

Marketing

Division of Business and Computer Information Systems

Division Dean — Dave Wassenaar

Faculty

Patricia Kishel

Counselor

Robert Grantham

PROGRAM LEARNING OUTCOMES (PLOs)

Marketing

A student who completes the marketing field of study will be able to:

- Understand the various marketing functions (product development, pricing, promotion, and distribution) and how organizations utilize these to produce goods and services that satisfy the needs and wants of consumers.
- Enhance his/her employment opportunity in the specific area of marketing.

ASSOCIATE IN ARTS DEGREE BUSINESS ADMINISTRATION Program Code: 1A16599

This curriculum is designed to provide an opportunity for the business major to achieve an Associate in Arts Degree Business Administration while completing the first and second year requirements for transfer to a four-year institution. While a baccalaureate degree is recommended preparation for those considering professional careers in business administration, completion of this curriculum will demonstrate commitment to the field and provide comprehensive preparation for upper-division work.

Students should consult a counselor and the catalog of the individual college or university to plan a program of study. The Internet site www.assist.org will also provide information for California public universities. Courses selected to fulfill the requirements of the associate degree should reflect requirements of the college to which the student plans to transfer.

To earn an Associate Degree students must complete: (1) all major course requirements with a minimum grade of “C”; (2) California State University General Education Breadth requirements (CSU GE Breadth) or IGETC General Education Plan; (3) any elective courses to complete a minimum of 60 units; (4) complete all graduation requirements; and, (5) have an overall GPA of 2.0. At least 50% of all major course work must be completed at Cypress College. **Students pursuing more than one specified departmental major may double count a maximum of 7 units to fulfill major requirements.**

Courses that fulfill major requirements for an Associate Degree at Cypress College might not be the same as those required for completing the major at a transfer institution offering a Baccalaureate Degree. For information on specific university requirements, please consult with your counselor, or visit the Transfer Center.

Required courses are listed in suggested sequence:

Course #	Title	Units
MGT 161 C	Introduction to Business	3
CIS 111 C	Computer Information Systems	3
*ECON 100 C	Principles of Economics — Macro	3
	or	
*ECON 100HC	Honors Principles of Economics	(3)
**ECON 105 C	Principles of Economics — Micro	3
	or	
**ECON 105HC	Honors Principles of Economics	(3)
MGT 240 C	Legal Environment of Business	3
	or	
MGT 241 C	Legal Aspects — Business Transactions	(3)
ACCT 101 C	Financial Accounting	4
ACCT 102 C	Managerial Accounting	4
MATH 130 C	Survey of Calculus	4
MKT 222 C	Principles of Marketing	3
	Total Units Required	30

Elective:

MGT 211 C	Writing for Business	3
-----------	----------------------	---

*A score of 3 or higher on the Advanced Placement (AP) Economics (macro) exam meets this requirement upon petition through Admissions and Records. See a counselor for more information.

**A score of 3 or higher on the Advanced Placement (AP) Economics (micro) exam meets this requirement upon petition through Admissions and Records. See a counselor for more information.

ASSOCIATE IN SCIENCE DEGREE MARKETING Program Code: 1S03764

This curriculum is designed to prepare students for careers in marketing — performing the activities that enable businesses to satisfy customers' needs and wants. Students will learn product development, pricing, promotion, and distribution methods while gaining skills in selling, retailing, advertising, market researching, and other marketing areas.

To earn an Associate Degree students must complete: (1) all major course requirements with a minimum grade of “C”; (2) 25 units of General Education Graduation Requirements; (3) the cultural diversity and reading requirements; (4) any elective courses to complete a minimum of 60 units; and, (5) have minimum GPA of 2.0. At least 50% of all major course work must be completed at Cypress College.

Courses that fulfill major requirements for an Associate Degree at Cypress College might not be the same as those required for completing the major at a transfer institution offering a Baccalaureate Degree. For information on specific university requirements, please consult with your counselor, or visit the Transfer Center.

Required courses are listed in suggested sequence:

Course #	Title	Units
MGT 161 C	Introduction to Business	3
MKT 103 C	Principles of Advertising	3
MKT 222 C	Principles of Marketing	3
MKT 105 C	Principles of Retailing	3
MKT 208 C	Principles of Selling	3
MKT 210 C	Consumer Behavior	3
Select a minimum of 3 units from the elective courses listed below		3
Total Units Required		21

Electives

MKT 205 C	Multicultural Markets In U.S.	3
MKT 224 C	International Marketing	3
MKT 201 C	Small Business Promotion	3
ACCT 101 C	Financial Accounting	4
MGT 151 C	Business Mathematics	3

MARKETING CERTIFICATE Program Code: 1C03764

Primary emphasis is to provide students with the necessary skills to carry out the key marketing functions in a business, developing, pricing, promoting, and distributing products and services.

To earn a certificate, students must complete the required courses as listed with a minimum grade of “C.” At least 50% of all course work must be completed at Cypress College.

Required courses are listed in suggested sequence:

Course #	Title	Units
MGT 161 C	Introduction to Business	3
MKT 103 C	Principles of Advertising	3
MKT 222 C	Principles of Marketing	3
MKT 105 C	Principles of Retailing	3
MKT 208 C	Principles of Selling	3
MKT 210 C	Consumer Behavior	3
Select a minimum of 3 units from the elective courses listed below		3
Total Units Required		21

Electives

MKT 205 C	Multicultural Markets In U.S.	3
MKT 224 C	International Marketing	3
MKT 201 C	Small Business Promotion	3
ACCT 101 C	Financial Accounting	4
MGT 151 C	Business Mathematics	3

AUTOMOTIVE SALES AND SERVICE CERTIFICATE Program Code: 1K15688

This program is designed to prepare students for customer service and sales positions in the automotive industry. It provides students with a basic knowledge of automobile operations, general maintenance requirements, and damage appraisal procedures along with marketing and management principles. The certificate will enable students to work in a variety of non technical areas in an automobile dealership, repair shop, or insurance company as a service representative, salesperson, or estimator.

To earn a certificate, students must complete the required courses as listed with a minimum grade of “C.” At least 50% of all course work must be completed at Cypress College.

Required courses are listed in suggested sequence:

Course#	Title	Units
AT 101 C	Survey of the Automobile	3
or		
AT 110 C	Automotive Fundamentals	(4)
ACR 012 C	Automotive Damage Appraisal	3
MGT 266 C	Human Relations in Business	3
MKT 222 C	Principles of Marketing	3
MKT 208 C	Principles of Selling	3
Total Units Required		15–16

GEOGRAPHIC INFORMATION SYSTEMS/MARKETING CERTIFICATE Program Code: 1K12953

This certificate program provides students with the skills to use Geographic Information Systems (GIS) computerized mapping techniques in the field of marketing. Combining the latest computer graphics and marketing research methods, students will learn to create maps to locate customers, evaluate business sites, plan distribution networks and sales territories, and find new business opportunities.

To earn a certificate, students must complete the required courses as listed with a minimum grade of “C.” At least 50% of all course work must be completed at Cypress College.

Required courses are listed in suggested sequence:

Course #	Title	Units
MKT 222 C	Principles of Marketing	3
MKT 210 C	Consumer Behavior	3
MKT 224 C	International Marketing	3
GEOG 230 C	Introduction to GIS	3
GEOG 231 C	GIS: Vector Applications	3
Total Units Required		15

PROFESSIONAL MARKETING CERTIFICATE Program Code: 1C31328

This certificate program provides students with a working knowledge of the marketing and sales activities required to satisfy customers’ needs and wants for goods and services. Program is designed for both marketing and sales professionals and those wishing to pursue marketing careers. To earn a certificate, complete the required courses as listed with a minimum grade of “C.” At least 50% of all course work must be completed at Cypress College.

Required courses are listed in suggested sequence:

Course #	Title	Units
MKT 090 C	Marketing Essentials	1
MKT 091 C	Advertising and Public Relations	1
MKT 092 C	Personal Selling	1
MKT 093 C	Target Marketing	.5
MKT 094 C	Buyer Behavior	.5
MKT 095 C	Market Distribution Systems	.5
MKT 096 C	Sales Promotion Techniques	.5
MKT 097 C	Customer Relations	.5
MKT 098 C	International Marketing — Small Business	.5
MKT 086 C	Sales Prospecting	.5
MKT 087 C	Sales Presentations	.5
MKT 088 C	Handling Sales Objections	.5
MKT 089 C	Making the Sale	.5
MGT 085 C	Business Planning	1
MGT 161 C	Introduction to Business	3
Total Units		12

SMALL BUSINESS OPERATIONS**CERTIFICATE****Program Code: 1C31342**

This certificate program provides students with information on the various steps and management and marketing decisions involved in starting and operating a business. Program is designed for both prospective and current business owners.

To earn a certificate, students must complete the required courses as listed with a minimum grade of “C.” At least 50% of all course work must be completed at Cypress College.

Required courses are listed in suggested sequence:

Course #	Title	Units
MGT 085 C	Business Planning	1
MGT 086 C	Business Finance — Recordkeeping	.5
MGT 087 C	Obtaining and Using Computers	.5
MGT 088 C	Managing Personnel	.5
MGT 089 C	Business Law — Small Business	.5
MKT 090 C	Marketing Essentials	1
MKT 091 C	Advertising and Public Relations	1
MKT 092 C	Personal Selling	1
MKT 093 C	Target Marketing	.5
MKT 094 C	Buyer Behavior	.5
MKT 095 C	Market Distribution Systems	.5
MKT 096 C	Sales Promotion Techniques	.5
MKT 097 C	Customer Relations	.5
MKT 098 C	International Marketing — Small Business	.5
MGT 161 C	Introduction to Business	3
Total Units		12

MARKETING TRANSFER PROGRAM**Refer to Catalog under:****BUSINESS ADMINISTRATION TRANSFER PROGRAM**

Students should consult a counselor or www.assist.org for lower division major requirements for most California public universities. (See the Standard Definitions section of the catalog for a description of ASSIST.) Students transferring to an independent college/university should consult the catalog of the individual school and a counselor for lower division major requirements.

Marketing (MKT)**MKT 086 C Sales Prospecting .5 Units**

Term hours: 8–9 lecture. This course focuses on ways to identify prospective customers and generate sales leads using such methods as mailing lists, databases, networking, referrals, and other information sources. Pass/No Pass only.

MKT 087 C Sales Presentations .5 Units

Term hours: 8–9 lecture. This course emphasizes the key elements of effective sales presentations and shows how to make each presentation come alive through the use of verbal, visual, and demonstration techniques. Pass/No Pass only.

MKT 088 C Handling Sales Objections .5 Units

Term hours: 8–9 lecture. This course shows how to get past “No,” using various sales strategies to overcome customers’ objections and to emphasize the benefits of a purchase. Pass/No Pass only.

MKT 089 C Making the Sale .5 Units

Term hours: 8–9 lecture. This course explains how and when to close a sale, focusing on the techniques that can be used to complete the transaction and generate repeat sales and customer referrals. Pass/No Pass only.

MKT 090 C Marketing Essentials 1 Unit

Term hours: 8–9 lecture. This course covers the business activities necessary to plan, promote, price and distribute a product or service to potential customers. It provides an understanding of the functions of producers, wholesalers, retailers, and others. Pass/No Pass only.

MKT 091 C Advertising and Public Relations 1 Unit

Term hours: 8–9 lecture. This course discusses the roles of advertising and public relations as part of the marketing mix a business puts together, providing strategies for identifying a target audience/choosing a message and media. Pass/No Pass only.

MKT 092 C Personal Selling 1 Unit

Term hours: 8–9 lecture. This course provides instruction in the techniques of finding and contacting sales prospects, identifying needs and wants, giving effective sales presentations, handling objections, and closing the sale. Pass/No Pass only.

MKT 093 C Target Marketing .5 Units

Term hours: 8–9 lecture. This course provides instruction in the fundamentals of marketing research to identify target markets and find out what customers want. Topics covered include data collection, interview and survey techniques, sources of information, and methods of trend analysis. Pass/No Pass only.

MKT 094 C Buyer Behavior .5 Units

Term hours: 8–9 lecture. This course explores the psychology of how and why customers buy, utilizing demographic and lifestyle factors to gain a better understanding of purchase decisions. Pass/No Pass only.

MKT 095 C Market Distribution Systems .5 Units

Term hours: 8–9 lecture. This course provides a thorough view of the distribution process, including the channels, types of retail outlets, methods of transportation, warehousing and inventory control. Pass/No Pass only.

MKT 096 C Sales Promotion Techniques .5 Units

Term hours: 8–9 lecture. This course will provide information on the wide variety of “non-media” techniques that can be used to promote a business, including cents-off coupons, gifts and contests, special events, participation in trade shows and other promotional devices. Pass/No Pass only.

MKT 097 C Customer Relations .5 Units

Term hours: 8–9 lecture. This course explores the ways to maintain and improve customer relations, develop customer loyalty and increase the level of repeat sales. Pass/No Pass only.

MKT 098 C International Marketing — Small Business .5 Units

Term hours: 8–9 lecture. This course is a study of the international marketplace and the various opportunities for businesses to sell products and services outside of the U.S. Pass/No Pass only.

MKT 103 C Principles of Advertising 3 Units

Term hours: 48–54 lecture. This course is a study of advertising and promotion, including the print media, copy and layout, radio and television commercials, the Internet, public relations, customer preferences and appeals, advertising campaigns, and evaluation. An ad agency point of view is presented creatively for students with interest in communications, photography, art multimedia, business, psychology, or sociology. (CSU)

MKT 105 C Principles of Retailing 3 Units

Term hours: 48–54 lecture. This course covers the principles involved in organizing and managing a retailing or E-tailing business, with emphasis on planning, site appeal, merchandise, pricing, and promotion. Students will also learn customer service techniques and ways to enhance the shopping experience. (CSU)

MKT 201 C Small Business Promotion 3 Units

Term hours: 48–54 lecture. This course focuses on the techniques used to promote a small business and develop its marketing strategy. Its emphasis is on creating a marketing plan and devising affordable and effective ways to communicate with customers through local media, and the Internet, sales promotion, publicity, brochures, direct mail and other methods. (CSU)

MKT 205 C Multicultural Markets in U.S. 3 Units

Term hours: 48–54 lecture. This course provides comprehensive coverage of the multicultural marketing environment in the United States, taking into consideration the changing needs and growing influence of ethnic and racial minorities, women, and other groups. Exploring the differences and commonalities that exist among the groups, the course examines the role of business and the United States' marketing system in providing goods and services to meet each groups' needs. (CSU, CUL DIV)

MKT 206 C Store Operations 3 Units

Term hours: 48–54 lecture. This course includes principles, procedures and functions of a retail store operation, with emphasis on techniques of buying merchandise. Current trends and practices are analyzed including layout, display, security controls, inventory records, control and management, pricing, coding and marking, receiving and stocking, merchandise planning, marketing, and distinctions between larger and smaller stores. (CSU)

MKT 208 C Principles of Selling 3 Units

Term hours: 48–54 lecture. This course includes instruction in the principles and practices of personal persuasion and selling and development of the techniques that lead to a successful sales personality. The areas of study include buying motives; product knowledge; all phases of the selling process; and the many and varied career opportunities in the sales field. Pass/No Pass/Letter Grade Option. (CSU)

MKT 209 C Display and Sales Promotion 3 Units

Term hours: 48–54 lecture. This course is a lecture/lab experience in contemporary merchandising promotion. The subject areas include planning and working with display units and sales promotion materials, customer motivation, design and layout, creative brainstorming, and future trends. (CSU)

MKT 210 C Consumer Behavior 3 Units

Term hours: 48–54 lecture. This course provides a study of consumers and how they buy. Consumerism, impulse buying, pleasure appeals, packaging, status symbols, the new woman, leisure time, California culture, personality, subliminal effects, and the psychology of advertising are covered. (CSU)

MKT 222 C Principles of Marketing 3 Units

Term hours: 48–54 lecture. This course is a study of business activities required to plan, price, promote, and distribute goods or services to potential customers. The areas of study include market research and consumer behavior, product development, advertising and sales, branding, pricing, Internet marketing, wholesaling and retailing, and international marketing. (CSU)

MKT 224 C International Marketing 3 Units

Term hours: 48–54 lecture. This course provides comprehensive coverage of the international marketing environment. The areas of study include the global marketplaces; import/exports; foreign economic, political and legal systems; cultural differences; international finance; marketing research; and business plans. (CSU)

MKT 299 C Merchandising/MKT — Indep. Study 1 to 3 Units

Prerequisite: Approved Independent Study Learning Contract.

Term hours: Lecture/discussion hours vary with credit given. The course is designed for capable students who wish to extend their knowledge of a particular area of merchandising/marketing through individual research and study. (CSU)

Mathematics

Division of Science/Engineering/Mathematics

Division Dean — Richard Fee

Faculty

Jennifer Coopman
Adam Eckenrode
Kathryn Godshalk
Nicole Ledesma
Eunju Lee
Chaolin Mao
Laurie Morvan
Allen Mottershead
David Nusbaum
Sylvia Paek
Christina Plett
Cindy Shrout

Counselor

Deidre Porter

PROGRAM LEARNING OUTCOMES (PLOs)

The courses taught by this department contribute to the General Education and Basic Skills Program Learning Outcomes. Please refer to General Education and Basic Skills Program Learning Outcomes.

Mathematics

Students who complete the mathematics program will be able to:

- Apply mathematical concepts, simplify expressions, and solve equations.
- Graph equations, and solve application problems using logic, constructions, and analytical reasoning.

MATHEMATICS TRANSFER PROGRAM

Students should consult a counselor or www.assist.org for lower division major requirements for most California public universities. (See the Standard Definitions section of the catalog for a description of ASSIST.) Students transferring to an independent college/university should consult the catalog of the individual school and a counselor for lower division major requirements.

Mathematics (MATH)**MATH 010 C Basic Mathematics 4 Units**

Term hours: 64–72 lecture. This is a course for students wishing to review basic arithmetic skills. It includes the concepts of adding, subtracting, multiplying, and dividing whole numbers, fractions, mixed numbers, and decimals. Also covered will be percents, ratios, rates, solving proportions, perimeter and area of geometric figures, English and Metric measurements and an introduction to negative numbers. There will be an emphasis on applying the mathematics to real-world situations. Non-Degree Credit.

MATH 015 C Pre-Algebra 4 Units

Prerequisite: MATH 010 C or Basic Mathematics with a grade of “C” or better and the assessment process. Proof of prerequisites is required.
Term hours: 64–72 lecture. This course is designed for students who are planning to study algebra and need a review of the basic skills of arithmetic and an introduction to the basic principles of algebra. Topics covered include integers, fractions, decimals, percent, proportions, exponents, properties of real numbers, evaluation of algebraic expressions, elementary equation solving, formulas, informal geometry, and applications. Non-Degree Credit.

MATH 020 C Elementary Algebra 4 Units

Prerequisite: MATH 015 C or Pre-algebra with a grade of “C” or better and the assessment process. Proof of prerequisites is required.
Term hours: 64–72 lecture. This course is an introduction to the methods of algebra. It includes the basic operations of real numbers, polynomials, rational expressions, and radical expressions; factoring polynomials; solutions of linear equations, linear inequalities, systems of linear equations, and quadratic equations; and graphing of linear equations, systems, and inequalities. Non-Degree Credit.

MATH 025 C Elementary Algebra Review 2 Units

Prerequisite: MATH 020 C or Algebra I with a grade of “C” or better and the assessment process. Proof of prerequisites is required.
Term hours: 32–36 lecture. This course is a review of the introductory methods of algebra and is designed for students who have completed Elementary Algebra and plan to enroll in Intermediate Algebra. It includes the basic operations of real numbers, polynomials, rational expressions, and radical expressions; factoring polynomials; solutions of linear equations, linear inequalities, systems of linear equations, and quadratic equations; and graphing of linear equations, systems, and inequalities. Non-Degree Credit. Pass/No Pass only.

MATH 030 C Plane Geometry 4 Units

Prerequisite: MATH 020 C or Algebra I with a grade of “C” or better and the assessment process. Proof of prerequisites is required.

Term hours: 64–72 lecture. This course is an introduction to Euclidean geometry. It includes elementary logic, deductive reasoning, theorems and proofs, geometric constructions, congruent and similar polygons, circles, geometric loci, areas, perimeters and volumes. Precise definitions and accuracy of statements are stressed as background for analytical reasoning. The course is equivalent to one year of high school geometry. (AA GE)

MATH 038 C Practical Mathematics for Life 4 Units

Prerequisite: A minimum grade of “C” in MATH 020 C or Algebra I with a grade of “C” or better and the assessment process. Proof of prerequisites is required.

Term hours: 64–72 lecture. This course uses the concepts of beginning algebra, problem solving skills, and analytical thinking to solve real world applications involving fractions, financial management, logic, geometry, probability and statistics. It meets the minimum mathematics requirement for an associates degree but does not satisfy the prerequisite for a transferable math course. (AA GE)

MATH 040 C Intermediate Algebra 4 Units

Prerequisite: MATH 020 C or Algebra I with a grade of “C” and the assessment process. Proof of prerequisites is required.

Course hours 64–72. This is a second course in algebra that includes the topics of sets, axioms for the real number system, polynomials, solutions of linear and quadratic equations and inequalities, exponents and radicals, linear, quadratic, exponential and logarithmic functions and their graphs, and systems of equations. (AA GE)

MATH 041 C Combined Algebra I and II 6 Units

Prerequisite: MATH 015 C or pre-algebra with minimum grades of “C,” AND the assessment process. Proof of prerequisites is required.

Term hours: 96–108. This course is designed for students who would like to complete Elementary and Intermediate Algebra in one semester. It covers linear, quadratic, and absolute value equations and inequalities, rational and radical equations, operations with polynomials, radicals, and rational expressions, systems of linear equations, and linear, quadratic, exponential, and logarithmic functions and their graphs. A non-graphing scientific calculator is required. (AA GE)

MATH 045 C Intermediate Algebra Review 2 Units

Prerequisite: MATH 040 C or Algebra II with a grade of “C” or better and the assessment process. Proof of prerequisites is required.

Term hours: 32–36 lecture. This course is designed for students who have already completed Intermediate Algebra and are planning to enroll in Survey of Calculus, College Algebra, Trigonometry, Finite Mathematics, Statistics, or General Chemistry. The topics include sets, axioms for the real number system, polynomials, solutions of linear and quadratic equations and inequalities, exponents and radicals, linear and quadratic functions and radicals, linear and quadratic functions and their graphs, exponential and logarithmic functions and systems of equations. This course does not count toward the Associate Degree. Non-Degree Credit. Pass/No Pass only.

MATH 098 C Mathematics Seminar .5 to 12 Units

Prerequisite: May be required.

Corequisite: May be required.

Advisory: May be required.

Term hours: 0–216 lecture and/or 0–432 laboratory depending on units attempted. This is a lecture/discussion approach to special topics involving mathematics. It may be a problem session relating to a particular course in the curriculum or a study of topics not ordinarily covered in the curriculum. Consult the class schedule to verify unit credit for a particular semester. May be taken for credit 1–4 times. Pass/No Pass or Pass/No Pass/Letter Grade Option or Standard Letter Grade. Fees may be required — Payable at Registration.

Flow Chart for Mathematics Courses

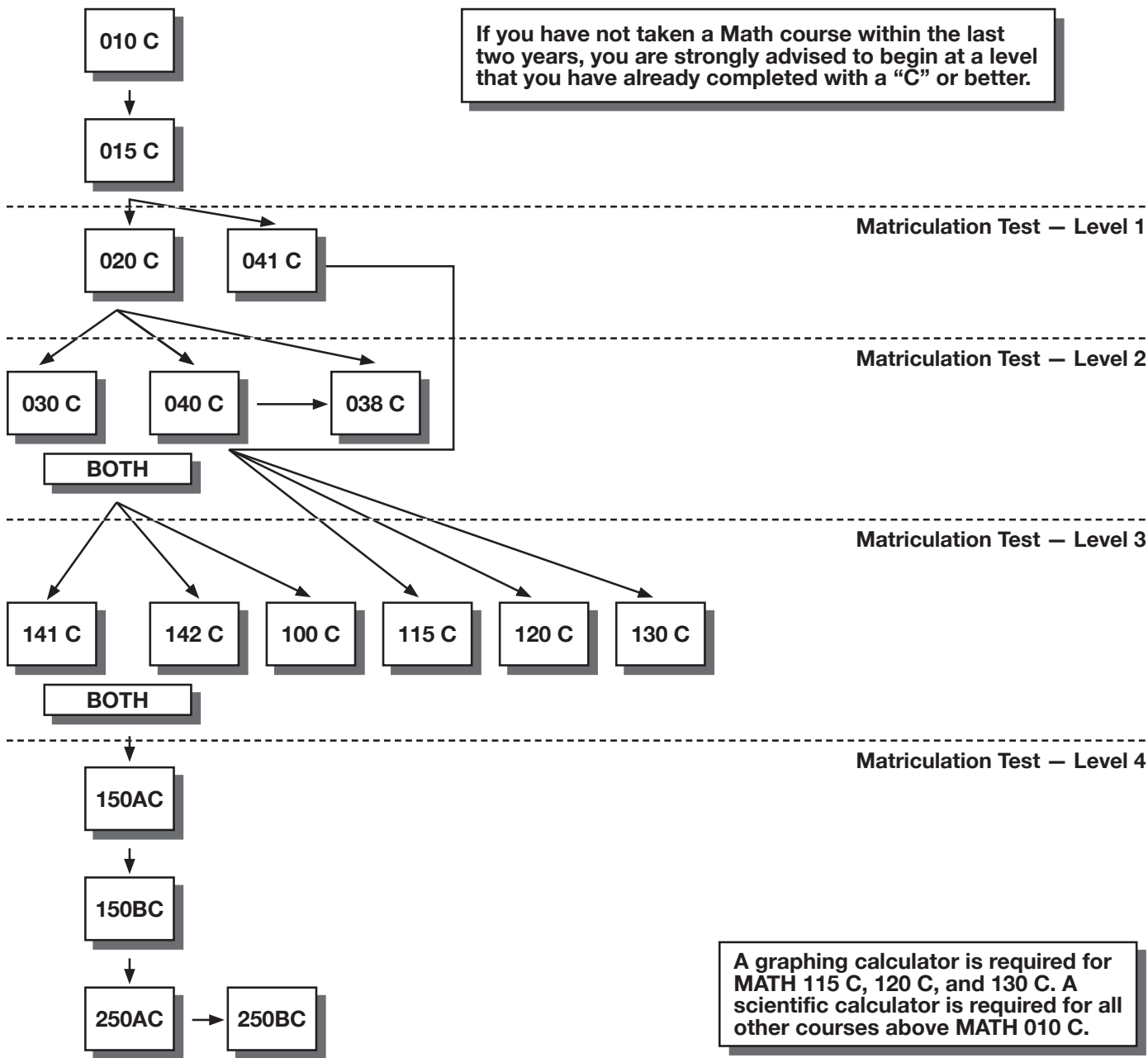

MATHEMATICS LEARNING CENTER (714) 484-7151

Students will find instructors and qualified tutors available for assistance in solving mathematical problems or in understanding mathematical concepts in the Mathematics Learning Center, located in Room 127 of the Library/Learning Resource Center.

MONDAY 8:00 am–8:00 pm
 TUESDAY 8:00 am–8:00 pm
 WEDNESDAY 8:00 am–8:00 pm
 THURSDAY 8:00 am–8:00 pm
 FRIDAY 10:00 am–3:00 pm

MATH 099 C Mathematics Independent Study .5 to 2 Units

Prerequisite: Approved Independent Study Learning Contract.

Term hours: 8–36 hours as assigned independent study or research. This course is for students who have demonstrated interest in and capability for increased knowledge of mathematical topics not ordinarily covered in curriculum courses. Students will participate in independent study or research on assigned projects under staff supervision. May be taken for credit 4 times. Pass/No Pass/Letter Grade Option.

MATH 100 C Liberal Arts Mathematics 3 Units

Prerequisite: MATH 030 C and MATH 040 C or Plane Geometry and Algebra II with grades of “C” or better and the assessment process. Proof of prerequisites is required.

Term hours: 48–54 lecture. This is a survey course with selected topics from the history and development of mathematics, elementary logic and set theory, probability, statistics, geometry, and exponential and logarithmic applications. The course is designed for prospective teachers and liberal arts students. (UC/CSU, AA GE, CSU GE, IGETC)

MATH 110 C Math for Prospective Teachers 4 Units

Prerequisite: MATH 030 C and MATH 040 C or Plane Geometry and Algebra II with grades of “C” or better and the assessment process. Proof of prerequisites is required.

Term hours: 64–72 lecture. This course is an introduction to problem solving processes and strategies. Students explore the development and analysis of the structure and operations of the real number system. Students focus on concept and process development using appropriate models, manipulatives, and activities. This course is designed for prospective elementary and middle school teachers. This course requires the use of a non-graphing scientific calculator. (UC/CSU, AA GE)

MATH 115 C Finite Mathematics 4 Units

Prerequisite: MATH 040 C or Algebra II with a grade of “C” or better and the assessment process. Proof of prerequisites is required.

Term hours: 64–72 lecture. This course covers graphing, finance, matrices, linear systems, linear programming, combinatorial analysis, probability, and descriptive statistics. Applications to the fields of business, economics, biological sciences, and behavioral sciences are emphasized. This course requires the use of a graphing calculator comparable to the TI-83/84. (UC/CSU, AA GE, CSU GE, IGETC)

MATH 120 C Introduction to Probability and Statistics 4 Units

Prerequisite: MATH 040 C or Algebra II with a grade of “C” or better and the assessment process. Proof of prerequisites is required.

Term hours: 64–72 lecture. This course is an introduction to the elements of statistical analysis which includes an intuitive approach to the study of probability and probability distributions, measures of central tendency and dispersion, sampling techniques, parametric and non-parametric tests of hypotheses, point and interval estimation, linear regression and correlation. Applications to business, biological sciences, and social sciences are emphasized. Students will use computer software and/or graphing calculators for statistical analysis of various topics. This course requires the use of a graphing calculator comparable to the TI-83/84. Duplicate credit not granted for MATH 120HC. (UC Credit Limitation/CSU, AA GE, CSU GE, IGETC)

MATH 130 C Survey of Calculus 4 Units

Prerequisite: MATH 040 C or Algebra II with a grade of “C” or better and the assessment process. Proof of prerequisites is required.

Term hours: 64–72 lecture. This course is an introduction to calculus with an emphasis on solution techniques and applications rather than abstract theory. It includes elements of analytic geometry, limits, derivatives, integration as a summation process, exponential and logarithmic functions, integration of basic forms, techniques of integration, an introduction to multi-variable calculus, and curve sketching, with applications from the life sciences, engineering technology, economics, and the social sciences. This course requires the use of a graphing calculator comparable to the TI-83/TI-84. Credit by Examination. (UC Credit Limitation/CSU, AA GE, CSU GE, IGETC)

MATH 141 C College Algebra 4 Units

Prerequisite: MATH 030 C and MATH 040 C with grades of “C” or better or plane geometry and Algebra II with grades of “C” or better and the assessment process. Proof of prerequisites is required.

Term hours: 64–72 lecture. This is one of two courses to prepare students for the calculus sequence. The topics covered include a review of the fundamentals of algebra; rational, exponential and logarithmic functions; theory of equations and zeros of polynomial functions; systems of equations including linear and quadratic systems; matrices and determinants; sequences and series; mathematical induction; permutations; combinations; binomial theorem; analytic geometry; conic sections; and miscellaneous topics. (UC/CSU, AA GE, CSU GE, IGETC)

MATH 142 C Trigonometry 4 Units

Prerequisite: MATH 030 C and MATH 040 C with grades of “C” or better or plane geometry and Algebra II with grades of “C” or better and the assessment process. Proof of prerequisites is required.

Advisory: MATH 141 C or the equivalent of Math Analysis or Precalculus with a grade of “C” or better.

Term hours: 64–72 lecture. This is a one-semester course in trigonometry designed to prepare students for the study of calculus. The topics to be covered include the following: measurements of angles, trigonometric and inverse trigonometric functions and their graphs, solving trigonometric equations, verifying trigonometric identities, solutions of triangles, complex numbers, polar coordinates, vectors, DeMoivre’s Theorem, and parametric equations. (CSU, AA GE, CSU GE)

MATH 150AC Calculus I 4 Units

Prerequisite: MATH 141 C and MATH 142 C or trigonometry and math analysis/precalculus with grades of “C” or better and the assessment process. Proof of prerequisites is required.

Term hours: 64–72 lecture. This course is an introduction to mathematical analysis. It includes the study of analytic geometry, functions and limits, continuity, differentiation and integration. Problem work includes applications involving derivatives, definite integrals and indefinite integrals. Credit by Examination. (UC Credit Limitation/CSU, AA GE, CSU GE, IGETC)

MATH 150BC Calculus II **4 Units**

Prerequisite: MATH 150AC or Calculus I and Analytic Geometry with a grade of "C" or better and the assessment process. Proof of prerequisites is required.

Term hours: 64–72 lecture. This course is a continuation of Mathematics 150AC which includes the study of applications of integration, techniques of integration, indeterminate forms, L'Hopital's rule, improper integrals, infinite sequences and series, Taylor and MacLaurin series, conic sections, plane curves, parametric equations, and polar coordinates. Credit by Examination. (UC/CSU, AA GE, CSU GE, IGETC)

MATH 250AC Multivariable Calculus **4 Units**

Prerequisite: MATH 150BC or Calculus II with a grade of "C" or better and the assessment process. Proof of prerequisites is required.

Term hours: 64–72 lecture. This is an intermediate course in mathematical analysis. It includes the study of three-dimensional analytic geometry, calculus of functions of several variables, vector calculus, multiple integration, vector fields and theorems, with associated problem applications. Credit by Examination. (UC/CSU, AA GE, CSU GE, IGETC)

MATH 250BC Linear Algebra/Differential Equations **4 Units**

Prerequisite: MATH 250AC or Multivariable Calculus with a grade of "C" or better and the assessment process.

Term hours: 64–72 lecture. This course is an introduction to linear algebra and ordinary differential equations. Linear algebra includes matrices, determinants, vector spaces, linear transformations, and characteristic values. Differential equations includes separable, exact, Cauchy-Euler, and non-homogeneous equations; undetermined coefficients, variation of parameters, series solutions, and systems of differential equations. Credit by Examination. (UC/CSU, AA GE, CSU GE, IGETC)

MATH 298 C Mathematics Seminar **.5 to 12 Units**

Prerequisite: May be required.

Corequisite: May be required.

Advisory: May be required.

Term hours: 0–216 lecture and/or 0–432 laboratory depending on units attempted. This is a lecture/discussion approach to special topics involving mathematics. It may be a problem session related to a particular course in the curriculum, or a study of topics not ordinarily covered in the curriculum. Consult the class schedule to verify unit credit for a particular semester. May be taken for credit 1–4 times. Pass/No Pass or Pass/No Pass/Letter Grade Option or Standard Letter Grade. Fees may be required — Payable at Registration. (UC Credit Limitation/CSU)

MATH 299 C Mathematics Independent Study **.5 to 2 Units**

Prerequisite: Approved Independent Study Learning Contract.

Term hours: 8–36 lecture depending on units attempted. This course is for students who have demonstrated interest in and capability for increased knowledge of mathematical topics not ordinarily covered in curriculum courses. Students will participate in independent study or research on assigned projects under staff supervision. May be taken for credit 4 times. (UC Credit Limitation/CSU)

MAD

Media Arts Design

(formerly Art Computer Graphics, ACG)

Division of Fine Arts

Division Dean — Ting-Pi (Joyce) Carrigan

Faculty

Edward Giardina

Ian Holmes

Michael Johnson

Counselors

Renay Laguana-Ferinac

Renee Ssensalo

PROGRAM LEARNING OUTCOMES (PLOs)**Media Arts Design**

- Given a variety of media arts design, web design, video, cinema, and animation processes, students will be able to demonstrate their knowledge of various computer graphics, cinema and time based processes, theory, and technical skills.
- Given media arts design, web design, video, cinema, and animation materials, students will be able to effectively communicate content through the principles and elements of design.
- Given media arts design, web design, video, cinema, and animation works and materials, students will be able to critically analyze the principles and elements of design for content and historical importance.
- Students will develop artistic skills to visually articulate and comprehend the interconnection between media arts design, web design, video, cinema, design and culture.

ANIMATION 2D COMPUTER GRAPHICS**CERTIFICATE**

Program Code: 1K15693

This Animation 2D Computer Graphics Certificate provides the skills necessary for publishing animation on web sites. Students will learn to create digital drawings, paintings and illustrations for the purpose of creating two-dimensional animated cartoons and interactive games suitable for the Internet and CD-ROMs. Emphasis is placed on development of a portfolio for employment and/or advancement.

To earn a certificate, students must complete the required courses as listed with a minimum grade of "C." At least 50% of all course work must be completed at Cypress College.

Required courses are listed in numeric sequence:

Course#	Title	Units
ART 120 C	Two-Dimensional Design	3
*ART 182 C	Freehand Drawing	3
MAD 102 C	Intro to Mac WEB Graphics or	3
MAD 103 C	Intro to Win WEB Graphics	(3)
MAD 134 C	Digital Imaging/Mac or	3
MAD 135 C	Digital Imaging/Win	(3)
MAD 164 C	Adobe Flash Designer/Mac or	3
MAD 165 C	Adobe Flash Designer/Win	(3)
Total Units Required		15

*A score of 3 or higher on the Advanced Placement (AP) Art (Studio Drawing) exam with portfolio meets this requirement upon petition through Admissions and Records. See a counselor for more information.

ANIMATION 3D COMPUTER GRAPHICS**CERTIFICATE** **Program Code: 1K15694**

The Animation 3D Computer Graphics Certificate provides the skills necessary to create three dimensional models and 3D animated short films appropriate for use in movies, television, electronic gaming, and Internet distribution. Emphasis is placed on development of a portfolio for employment and/or advancement.

To earn a certificate, students must complete the required courses as listed with a minimum grade of "C." At least 50% of all course work must be completed at Cypress College.

Required courses are listed in numeric sequence:

Course #	Title	Units
MAD 104 C	Intro to Mac 3D Graphics	3
MAD 105 C	Intro to Win 3D Graphics	3
MAD 120 C	3D Modeling/Mac or	3
MAD 121 C	3D Modeling/Win	(3)
MAD 150 C	Intermediate Animation/Mac or	3
MAD 151 C	Intermediate Animation/Win	(3)
MAD 156 C	Advanced Animation/Mac	3
MAD 157 C	Advanced Animation/Win	3
MAD 180 C	Digital Video/Mac or	3
MAD 181 C	Digital Video/Win	(3)
Total Units Required		21

COMPUTER GRAPHICS**CERTIFICATE** **Program Code: 1C03815**

The Computer Graphics program provides the skills necessary to create raster based digital drawings, paintings and illustrations. Emphasis is placed on development of a portfolio for employment and/or advancement.

To earn a certificate, students must complete the required courses as listed with a minimum grade of "C." At least 50% of all course work must be completed at Cypress College.

Required courses are listed in suggested sequence:

Course #	Title	Units
ART 120 C	Two-Dimensional Design	3
*ART 182 C	Freehand Drawing	3
ART 189 C	Fundamentals of Painting	3
ART 244 C	Illustration	3
MAD 100 C	Intro to Computer Graphics/Mac or	3
MAD 101 C	Intro to Computer Graphics/Win or	(3)
MAD 102 C	Intro to Mac WEB Graphics or	(3)
MAD 103 C	Intro to Win WEB Graphics	(3)
MAD 112 C	Electronic Illustration/Mac or	3
MAD 113 C	Electronic Illustration/Win	(3)
MAD 132 C	Electronic Paint/Mac or	3
MAD 133 C	Electronic Paint/Win	(3)
MAD 134 C	Digital Imaging/Mac or	3
MAD 135 C	Digital Imaging/Win	(3)
Select a minimum of 6 units from the elective courses listed below		6
Total Units Required		30

Electives

ART 140 C	Advertising/Graphic Design 1	3
*ART 182 C	Freehand Drawing	3
ART 185 C	Life Drawing	3
MAD 114 C	Electronic Illustration 2/Mac or	3
MAD 115 C	Electronic Illustration 2/Win	(3)

*A score of 3 or higher on the Advanced Placement (AP) Art (Studio Drawing) exam with portfolio meets this requirement upon petition through Admissions and Records. See a counselor for more information.

DIGITAL CINEMA ARTS AND INDUSTRY**CERTIFICATE** **Program Code: 1K30290**

The Digital Cinema Arts and Industry Certificate provides a foundation in the field of time-based media creation which includes video and audio recording for multiple platform exhibition and distribution. The certificate will prepare students to enter the fields of motion picture, television, multimedia, Internet and wireless media by providing a foundation set of courses that cover digital content creation. Students will learn the operation and application of software and hardware specific to these industries.

	Units	
MM 100 C	Introduction to Multimedia	3
MAD 107 C	Motion Graphics I	3
MAD 109 C	Digital Video Production I	3
MAD 110 C	Animation History/Technology	3
MAD 180 C	Digital Video/Mac	3
MAD 182 C	Digital Cinematography	3
Total Units		18

DIGITAL CINEMA PRODUCTION CERTIFICATE

Program Code: 1K30289

The Digital Cinema Production certificate provides production knowledge and skills used by digital artists to perform a variety of production duties in the live-action and animation areas of motion picture and time-based media creation. This certificate is the second certificate in a sequence of skills based certificates for Digital Cinema.

Required courses are listed in suggested sequence		Units
MAD 185 C	Documentary Digital Cinema	3
MAD 187 C	Motion Graphics II	3
MAD 188 C	Video Production II	3
MAD 186 C	Wedding and Event Videography	3
MAD 183 C	Preproduction for Filmmakers	3
MAD 191 C	Film Noir Genre	3
	or	
MAD 192 C	Great Directors of Cinema	(3)
	or	
MAD 193 C	Introduction to 2D Animation	(3)
	or	
THEA 230 C	Directing Actors for Film/TV	(2)
	Total Units	18

DIGITAL CINEMA TECHNIQUES AND TECHNOLOGIES

Program Code: 1C31229

The Digital Cinema Techniques and Technologies certificate provides both historical and technical knowledge of cinema skills and practices. These areas are examined by specific film genre. Development of lighting, filming, recording, editing and directing are focused on within this certificate. To earn a certificate, complete the required courses as listed with a minimum grade of "C." At least 50% of all course work must be completed at Cypress College.

Required courses are listed in numeric sequence:		Units
MAD 109 C	Digital Video Production I	3
MAD 192 C	Great Directors of Cinema	3
MAD 197 C	Western Film Genre	3
MUS 127 C	Music in Film	3
THEA 230 C	Directing Actors for Film/TV	2
	Total Units	14

POST PRODUCTION BASICS FOR CINEMA AND VIDEO

Program Code: 1C31200

The Post Production Basics for Cinema and Video certificate will teach students to use computer hardware and software to add sound and music to an existing video recording or digital film. In addition, it will teach students how to edit video and combine live action and animated content with visual effects. To earn a certificate, complete the required courses as listed with a minimum grade of "C." At least 50% of all course work must be completed at Cypress College.

Required courses are listed in numeric sequence:		Units
MAD 180 C	Digital Video/Mac	3
MAD 195 C	Science Fiction Film Genre	3
MUS 222 C	Audio Production for Film I	3
MUS 223 C	Audio Production for Film II	3
	Total Units	12

ELECTRONIC PUBLISHING DESIGN CERTIFICATE

Program Code: 1C07834

The Electronic Publishing Design Program provides the skills necessary to create Ad-design art and to generate digital "camera ready" page layouts. Emphasis is placed on development of a portfolio for employment and/or advancement.

To earn a certificate, students must complete the required courses as listed with a minimum grade of "C." At least 50% of all course work must be completed at Cypress College.

Required courses are listed in suggested sequence:

Course #	Title	Units
ART 120 C	Two-Dimensional Design	3
ART 182 C	Freehand Drawing	3
ART 140 C	Advertising/Graphic Design 1	3
ART 141 C	Advertising/Graphic Design 2	3
MAD 100 C	Intro to Computer Graphics/Mac	3
	or	
MAD 101 C	Intro to Computer Graphics/Win	(3)
	or	
MAD 102 C	Intro to Mac WEB Graphics	(3)
	or	
MAD 103 C	Intro to Win WEB Graphics	(3)
MAD 112 C	Electronic Illustration/Mac	3
	or	
MAD 113 C	Electronic Illustration/Win	(3)
MAD 134 C	Digital Imaging/Mac	3
	or	
MAD 135 C	Digital Imaging/Win	(3)
MAD 140 C	Desktop Publishing 1/Mac	3
	or	
MAD 141 C	Desktop Publishing 1/Win	(3)
	or	
MAD 142 C	Desktop Publishing 2/Mac	(3)
	or	
MAD 143 C	Desktop Publishing 2/Win	(3)
MAD 146 C	Desktop Publishing 3/Mac	3
	or	
MAD 147 C	Desktop Publishing 3/Win	(3)
	Select a minimum of 3 units from the elective courses listed below	3
	Total Units Required	30

Electives

ART 130 C	Printmaking	3
ART 142 C	Advertising/Graphic Design 3	3
ART 185 C	Life Drawing	3
ART 244 C	Illustration	3

VECTOR ILLUSTRATION CERTIFICATE

Program Code: 1C12358

The Computer Graphics program provides the skills necessary to create vector based digital drawings, paintings and illustrations. Emphasis is placed on development of a portfolio for employment and/or advancement.

To earn a certificate, students must complete the required courses as listed with a minimum grade of "C." At least 50% of all course work must be completed at Cypress College.

Required courses are listed in suggested sequence:

Course #	Title	Units
ART 120 C	Two-Dimensional Design	3
ART 182 C	Freehand Drawing	3
ART 189 C	Fundamentals of Painting	3
ART 244 C	Illustration	3
MAD 100 C	Intro to Computer Graphics/Mac or	3
MAD 101 C	Intro to Computer Graphics/Win or	(3)
MAD 102 C	Intro to Mac WEB Graphics or	(3)
MAD 103 C	Intro to Win WEB Graphics	(3)
MAD 112 C	Electronic Illustration/Mac or	3
MAD 113 C	Electronic Illustration/Win	(3)
MAD 114 C	Electronic Illustration 2/Mac or	3
MAD 115 C	Electronic Illustration 2/Win	(3)
MAD 134 C	Digital Imaging/Mac or	3
MAD 135 C	Digital Imaging/Win	(3)
Select a minimum of 6 units from the elective courses listed below		6
Total Units Required		30
Electives		
MAD 132 C	Electronic Paint/Mac or	3
MAD 133 C	Electronic Paint/Win	(3)
ART 140 C	Advertising/Graphic Design 1	3
ART 182 C	Freehand Drawing	3
ART 185 C	Life Drawing	3

MULTIMEDIA PRODUCTION**BASICS****Program Code: 1C31194**

The Multimedia Production Basics certificate provides a foundation of multimedia content creation skills necessary to be a competent multimedia author for social media and business communications and entertainment industry media. To earn a certificate, complete the required courses as listed with a minimum grade of "C." At least 50% of all course work must be completed at Cypress College.

Required courses are listed in numeric sequence:

Course #	Title	Units
MAD 119 C	Multimedia Mobile Design	3
MAD 184 C	Digital Video Explorations	3
MUS 108 C	Intro to Music Technology	3
MUS 127 C	Music in Film	3
Total Units		12

Media Arts Design (MAD)**MAD 100 C Introduction to Computer Graphics/Mac 3 Units**

Term hours: 32–36 lecture and 64–72 laboratory TBA. This course focuses on the use of paint, drawing and page layout programs. The use of various input and output devices will be covered. Designed for artists to input, create, manipulate and output graphic imagery. This class is intended as a gateway into the varied offerings of the Media Arts Design program, where the student can pursue more in-depth study on the topic(s) that most attracted them during this introductory class. \$20.00 Material Fee — Payable at Registration. (CSU)

MAD 101 C Introduction to Computer Graphics/Win 3 Units

Term hours: 32–36 lecture and 64–72 laboratory TBA. This course focuses on the use of paint, drawing and page layout programs. The use of various input and output devices will be covered. Designed for artists to input, create, manipulate and output graphic imagery. This class is intended as a gateway into the varied offerings of the Media Arts Design program, where the student can pursue more in-depth study on the topic(s) that most attracted them during this introductory class. \$20.00 Material Fee — Payable at Registration. (CSU)

MAD 102 C Introduction to Mac Web Graphics 3 Units

Term hours: 32–36 lecture and 64–72 laboratory TBA. This is an overview of the many uses of computer multimedia, with an emphasis on electronic publishing over the Internet. In the course of the semester, the students create a personal web page enriched with such audiovisual elements as animation, sound, video, 3D, and different types of still images. This class is intended as a gateway into the varied offerings of the Media Arts Design program, where the student can pursue more in-depth study on the topic(s) that most attracted them during this introductory class. \$20.00 Material Fee — Payable at Registration. (CSU)

MAD 103 C Introduction to Win Web Graphics 3 Units

Term hours: 32–36 lecture and 64–72 laboratory TBA. This is an overview of the many uses of computer multimedia, with an emphasis on electronic publishing over the Internet. In the course of the semester, the students create a personal Web page enriched with such audiovisual elements as animation, sound, video, 3D, and different types of still images. This class is intended as a gateway into the varied offerings of the Media Arts Design program, where the student can pursue more in-depth study on the topic(s) that most attracted them during this introductory class. \$20.00 Material Fee — Payable at Registration. (CSU)

MAD 104 C Introduction to MAC 3D Graphics 3 Units

Term hours: 32–36 lecture and 64–72 laboratory TBA. This is an overview of 3D computer graphics, with an emphasis on 2D paint and 3D modeling and animation software used in animation on the Macintosh. In the course of the semester, students create original 3D still and animation imagery for their portfolio. This class is intended as a gateway into the varied offerings of the Media Arts Design program, where the student can pursue more in-depth study on the topic(s) that most attracted them during this introductory class. \$20.00 Material Fee — Payable at Registration. (CSU)

MAD 105 C Introduction to Win 3D Graphics 3 Units

Term hours: 32–36 lecture and 64–72 laboratory TBA. This is an overview of 3D computer graphics, with an emphasis on 2D paint and 3D modeling and animation software used in animation on a Windows computer. In the course of the semester, students create original 3D still and animation imagery for their portfolio. This class is intended as a gateway into the varied offerings of the Media Arts Design program, where the student can pursue more in-depth study on the topic(s) that most attracted them during this introductory class. \$20.00 Material Fee — Payable at Registration. (CSU)

MAD 107 C Motion Graphics I 3 Units

Term hours: 32–36 lecture and 64–72 laboratory TBA. This course introduces students to the motion graphics capabilities of Apple Motion. Projects assigned during the course will increase students' skill with both the creative and the technical challenges posed by motion graphics based on common professional uses of Apple Motion for web, broadcast and film industries. Students will create projects that will be suitable for use in video and animation productions. May be taken for credit 3 times. \$20.00 Materials Fee — Payable at Registration. (CSU)

MAD 109 C Digital Video Production I 3 Units

Term hours: 32–36 lecture and 64–72 laboratory TBA. This course introduces digital video production techniques including single camera operation and procedures, basic principles and techniques of sound and scriptwriting, and digital video editing. Course topics include the operation of digital camcorders; lighting and sound equipment and post production digital editing suites; concepts and techniques of nonlinear digital editing, including organization of the editing process; working the time line and audio editing, with emphasis on the principles and aesthetics of video editing. May be taken for credit 3 times. \$20.00 Material Fee — Payable at Registration. (CSU)

MAD 110 C Animation History/Technology 3 Units

Term hours 48–54 lecture. This course is an introduction to the history and technological development of the field of animation. Animation will be explored from various perspectives: chronology, form, culture, and by personality. Emphasis is placed on examining how animation records, reflects and comments on world events and culture. (CSU)

MAD 112 C Electronic Illustration/Mac 3 Units

Term hours: 32–36 lecture and 64–72 laboratory TBA. The course focuses on the Macintosh generation of Postscript (vector) images for integration into desktop publishing/page layout software and as stand-alone images allowing high resolution output. The course offers the professional artist basic Macintosh skills needed for employment and/or advancement. \$20.00 Material Fee — Payable at Registration. (CSU)

MAD 113 C Electronic Illustration/Win 3 Units

Term hours: 32–36 lecture and 64–72 laboratory TBA. The course focuses on the Windows generation of Postscript (vector) images for integration into desktop publishing/page layout software and as stand-alone images allowing high-resolution output. The course offers the professional artist basic Windows skills needed for employment and/or advancement. \$20.00 Material Fee — Payable at Registration. (CSU)

MAD 114 C Electronic Illustration 2/Mac 3 Units

Term hours: 32–36 lecture and 64–72 laboratory TBA. This course is intended for the graphic designer, illustrator and fine artist, focusing on the advanced usage of several 2D vector based drawing software packages. The course focuses on the advanced usage of Macintosh generation of Postscript (vector) images for integration into desktop publishing/page layout software and as stand-alone images allowing high-resolution output. The course offers the professional artist advanced Macintosh skills needed for employment and/or advancement. \$20.00 Material Fee — Payable at Registration. (CSU)

MAD 115 C Electronic Illustration 2/Win 3 Units

Term hours: 32–36 lecture and 64–72 laboratory TBA. This course is intended for the graphic designer, illustrator and fine artist, focusing on the advanced usage of several 2D vector based drawing software packages. The course focuses on the advanced usage of Windows generation of Postscript (vector) images for integration into desktop publishing/page layout software and as stand-alone images allowing high-resolution output. The course offers the professional artist advanced Windows skills needed for employment and/or advancement. \$20.00 Material Fee — Payable at Registration. (CSU)

MAD 119 C Multimedia Mobile Design 3 Units

Term hours: 32–36 lecture and 64–72 laboratory TBA. This class is designed to introduce the student to the various disciplines involved in the creation of multimedia products including evolving mobile platforms. These disciplines include, computer graphics and visual design, web based content creation, digital photography, video recording, video editing, digital illustration and animated content. \$20.00 Material Fee — Payable at Registration. (CSU)

MAD 120 C 3D Modeling/Mac 3 Units

Term hours: 32–36 lecture and 64–72 laboratory TBA. This course focuses on computer generated 3D design techniques through the use of Macintosh based three-dimensional design programs. The course emphasis is on the introduction of three-dimensional concepts, the use of modeling tools, menu structures and modeling building applications of 3D design systems. Skills taught in this course will give students the ability to create original three-dimensional computer generated models of organic or mechanical design and animate them. \$20.00 Material Fee — Payable at Registration. (CSU)

MAD 121 C 3D Modeling/Win 3 Units

Term hours: 32–36 lecture and 64–72 laboratory TBA. This course focuses on computer generated 3D design techniques through the use Windows based three-dimensional design programs. The course emphasis is on the introduction of three-dimensional concepts, the use of modeling tools, menu structures and modeling building applications of 3D design systems. Skills taught in this course will give students the ability to create original three-dimensional computer generated models of organic or mechanical design and animate them. \$20.00 Material Fee — Payable at Registration. (CSU)

MAD 132 C Electronic Paint/Mac 3 Units

Term hours: 32–36 lecture and 64–72 laboratory TBA. The course focus is on the usage of Macintosh based software using a variety of natural-media software for the manipulation of bit-mapped (raster) images. Course topics include creation of original drawings; paintings and illustrations, using an assortment of digitally based chalks, pens, paints, inks, papers and textures. The course offers the professional artist raster based digital drawing /painting and illustration skills, on a Macintosh computer, needed for employment and/or advancement. \$20.00 Material Fee — Payable at Registration. (CSU)

MAD 133 C Electronic Paint/Win 3 Units

Term hours: 32–36 lecture and 64–72 laboratory TBA. The course focus is on the usage of Microsoft Windows based software using a variety of natural-media software for the manipulation of bit-mapped (raster) images. Course topics include creation of original drawings; paintings and illustrations, using an assortment of digitally based chalks, pens, paints, inks, papers and textures. The course offers the professional artist raster based digital drawing /painting and illustration skills, on a Windows computer, needed for employment and/or advancement. \$20.00 Material Fee — Payable at Registration. (CSU)

MAD 134 C Digital Imaging/Mac 3 Units

Term hours: 32–36 lecture and 64–72 laboratory TBA. The course focus is on the usage of Macintosh based software for the manipulation of bit-mapped (raster) images using illustrative, photographic, scanned and video images as the basis for image manipulation. Course topics include image enhancement, editing, composite, retouching, photo montages, prepress, color separations and web based images. \$20.00 Material Fee — Payable at Registration. (CSU)

MAD 135 C Digital Imaging/Win 3 Units

Term hours: 32–36 lecture and 64–72 laboratory TBA. The course focus is on the usage of Microsoft Windows based software for the manipulation of bit-mapped (raster) images using illustrative, photographic, scanned and video images as the basis for image manipulation. Course topics include image enhancement, editing, composite, retouching, photomontages, prepress, color separations and Web based images. \$20.00 Material Fee — Payable at Registration. (CSU)

MAD 136 C Digital Imaging 2/Mac 3 Units

Term hours: 32–36 lecture and 64–72 laboratory TBA. The course focus is on the advanced usage of Macintosh based software for the manipulation of bit-mapped (raster) images using illustrative, photographic, scanned and video images as the basis for image manipulation. Course topics include image enhancement, editing, composite, retouching, photo montages, prepress, color separations and web based images. \$20.00 Material Fee — Payable at Registration. (CSU)

MAD 137 C Digital Imaging 2/Win 3 Units

Term hours: 32–36 lecture and 64–72 laboratory TBA. The course focus is on the advanced usage of Windows based software for the manipulation of bit-mapped (raster) images using illustrative, photographic, scanned and video images as the basis for image manipulation. Course topics include image enhancement, editing, composite, retouching, photo montages, prepress, color separations and web based images. \$20.00 Material Fee — Payable at Registration. (CSU)

MAD 140 C Desktop Publishing 1/Mac 3 Units

Term hours: 32–36 lecture and 64–72 laboratory TBA. This course focuses on the use of Macintosh software as an Ad-design tool to generate “digital camera ready” page layouts, integrating graphics, illustrations, photographs and text. Emphasis is placed on design of the page, precision and accuracy allowed by the computer, and varied output options for color composites and separations. Course topics include page design, page layout, text editing, font manipulation, importing artwork, prepress tools, spot and color separations. \$20.00 Material Fee — Payable at Registration. (CSU)

MAD 141 C Desktop Publishing 1/Win 3 Units

Term hours: 32–36 lecture and 64–72 laboratory TBA. This course focuses on the use of Microsoft Windows software as an Ad-design tool to generate “digital camera ready” page layouts, integrating graphics, illustrations, photographs and text. Emphasis is placed on design of the page, precision and accuracy allowed by the computer, and varied output options for color composites and separations. Course topics include page design, page layout, text editing, font manipulation, importing artwork, prepress tools, spot and color separations. \$20.00 Material Fee — Payable at Registration. (CSU)

MAD 142 C Desktop Publishing 2/Mac 3 Units

Term hours: 32–36 lecture and 64–72 laboratory TBA. This course focuses on the intermediate use of Macintosh software as an Ad-design tool to generate page layouts, integrating graphics, illustrations, photographs and text. Emphasis is placed on the design of multi page layout for various types of publications, prepress, color separation and providing “digital camera ready” files for commercial projects. \$20.00 Material Fee — Payable at Registration. (CSU)

MAD 143 C Desktop Publishing 2/Win 3 Units

Term hours: 32–36 lecture and 64–72 laboratory TBA. This course focuses on the intermediate use of Windows software as an Ad-design tool to generate page layouts, integrating graphics, illustrations, photographs and text. Emphasis is placed on the design of multi page layout for various types of publications, prepress, color separation and providing “digital camera ready” files for commercial projects. \$20.00 Material Fee — Payable at Registration. (CSU)

MAD 146 C Desktop Publishing 3/Mac 3 Units

Term hours: 32–36 lecture and 64–72 laboratory TBA. This course focuses on the advanced use of Macintosh based software as an Ad-design tool to generate digital “camera ready” page layouts, integrating graphics, illustrations, photographs and text. Emphasis on computer assisted layout, design and production techniques used in a “hands on” environment to create Visions magazine. \$20.00 Material Fee — Payable at Registration. (CSU)

MAD 147 C Desktop Publishing 3/Win 3 Units

Term hours: 32–36 lecture and 64–72 laboratory TBA. This course focuses on the advanced use of Windows based software as an Ad-design tool to generate digital “camera ready” page layouts, integrating graphics, illustrations, photographs and text. Emphasis on computer assisted layout, design and production techniques used in a “hands on” environment to create Visions magazine. \$20.00 Material Fee — Payable at Registration. (CSU)

MAD 150 C Intermediate Animation/Mac 3 Units

Term hours: 32–36 lecture and 64–72 laboratory TBA. The course focuses on intermediate skills in 3D computer modeling and animation with a Macintosh software program that is a standard in the industry. The course focus is on intermediate techniques in modeling, texturing, lighting, motion control, and rendering animations for various purposes. Skills taught in this course will give students the ability to create original three-dimensional computer generated models of intermediate organic or mechanical design with a high degree of realism and resolution. Animation techniques explored will provide cinematic realism and presentation. \$20.00 Material Fee — Payable at Registration. (CSU)

MAD 151 C Intermediate Animation/Win 3 Units

Term hours: 32–36 lecture and 64–72 laboratory TBA. The course focuses on intermediate skills in 3D computer modeling and animation with a Windows software program that is a standard in the industry. The course focus is on intermediate techniques in modeling, texturing, lighting, motion control, and rendering animations for various purposes. Skills taught in this course will give students the ability to create original three-dimensional computer generated models of intermediate organic or mechanical design with a high degree of realism and resolution. Animation techniques explored will provide cinematic realism and presentation. \$20.00 Material Fee — Payable at Registration. (CSU)

MAD 156 C Advanced Animation/Mac 3 Units

Term hours: 32–36 lecture and 64–72 laboratory TBA. The course focuses on advanced skills in 3D computer modeling and animation with a Macintosh software program that is a standard in the industry. The course focus is on advanced techniques in modeling, texturing, lighting, motion control, and rendering animations for various purposes. Skills taught in this course will give students the ability to create original three-dimensional computer generated models of advanced organic or mechanical design with a high degree of realism and resolution. Animation techniques explored will provide cinematic realism and presentation. The course will combine 3D modeling and animation with 2D graphics imagery through mapping, editing techniques and visual effects. \$20.00 Material Fee — Payable at Registration. (CSU)

MAD 157 C Advanced Animation/Win 3 Units

Term hours: 32–36 lecture and 64–72 laboratory TBA. The course focuses on advanced skills in 3D computer modeling and animation with a Windows software program that is a standard in the industry. The course focus is on advanced techniques in modeling, texturing, lighting, motion control, and rendering animations for various purposes. Skills taught in this course will give students the ability to create original three-dimensional computer generated models of advanced organic or mechanical design with a high degree of realism and resolution. Animation techniques explored will provide cinematic realism and presentation. The course will combine 3D modeling and animation with 2D graphics imagery through mapping, editing techniques and visual effects. \$20.00 Material Fee — Payable at Registration. (CSU)

MAD 162 C Multimedia Web Design/Mac 3 Units

Term hours: 32–36 lecture and 64–72 laboratory TBA. The course focuses on the Macintosh generation of multi-media content for integration into interactive visual presentations with a primary focus on web publishing. Students will create personal interactive presentations by using drawings, photographs, charts, graphs, sound, text and 2D animation. The final presentations will use various outputs including Web, CD, DVD and video. The course offers the professional artist Macintosh multi media skills needed for employment and/or advancement. \$20.00 Material Fee — Payable at Registration. (CSU)

MAD 163 C Multimedia Web Design/Win 3 Units

Term hours: 32–36 lecture and 64–72 laboratory TBA. The course focuses on the Windows generation of multi-media content for integration into interactive visual presentation. Students will create personal interactive presentations by using drawings, photographs, charts, graphs, sound, text and 2D animation. The final presentations will use various outputs including Web, CD, videotape, color and black and white laser printers etc. The course offers the professional artist windows multi media skills needed for employment and/or advancement. \$20.00 Material Fee — Payable at Registration. (CSU)

MAD 164 C Adobe Flash Designer/Mac 3 Units

Term hours: 32–36 lecture and 64–72 laboratory TBA. The course focuses on the advanced usage of Adobe Flash for Macintosh generated multi-media content for integration into interactive visual presentations. Students will create advanced personal interactive presentations for web, CD-ROMs, and video display. Current software and hardware tools and techniques for designing and programming interactive multimedia presentations will be explored using Adobe Flash. The course offers the professional artist advanced Macintosh multi media skills needed for employment and/or advancement. \$20.00 Material Fee — Payable at Registration. (CSU)

MAD 165 C Adobe Flash Designer/Win 3 Units

Term hours: 32–36 lecture and 64–72 laboratory TBA. The course focuses on the advanced usage of Adobe Flash for Windows generated multi-media content for integration into interactive visual presentations. Students will create advanced personal interactive presentations for web, CD-ROMs, and video display. Current software and hardware tools and techniques for designing and programming interactive multimedia presentations will be explored using Adobe Flash. The course offers the professional artist advanced Windows multi media skills needed for employment and/or advancement. \$20.00 Material Fee — Payable at Registration. (CSU)

MAD 180 C Video Editing/MAC 3 Units

Term hours: 32–36 lecture and 64–72 laboratory TBA. The course includes the study and hands on use computers, assorted hardware, software, media recorders, and other tools and techniques used for editing and composition of video and audio sources. The course is to provide a thorough introduction to the world of digital video editing used in the fields of multimedia, digital cinema, web based streaming video and mobile video distribution. May be taken for credit 3 times. \$20.00 Material Fee — Payable at Registration. (CSU)

MAD 181 C Video Editing/WIN 3 Units

Term hours: 32–36 lecture and 64–72 laboratory TBA. The course includes the study and hands on use of Windows computers, assorted software, CD-ROMs, videodiscs, and other tools and techniques used for digitizing, editing and composition of video and audio sources. The course is to provide a thorough introduction to the world of desktop video used in the fields of multimedia, video editing (both on line and off line) and the creation of Quicktime movies. May be repeated for credit 3 times. \$20.00 Material Fee — Payable at Registration. (CSU)

MAD 182 C Cinematography 3 Units

Term hours: 32–36 lecture and 64–72 laboratory TBA. This is a course in digital cinema planning and production taught through hands-on experience, research and video production. Course topics include digital cinema as a distinct form of artistic expression; an investigation of the aesthetic, technological, economic, and social factors that contributed to the evolution of digital cinema; logistics, script development, sound recording, video and sound editing; and methods by which the visual and aural elements may be organized. The roles and responsibilities of the digital cinema artist will be examined, including skills and knowledge required in developing, budgeting, managing, producing, and distributing programs. May be taken for credit 3 times. \$20.00 Material Fee — Payable at Registration. (CSU)

MAD 183 C Preproduction for Filmmakers 3 Units

Term hours: 48–54 lecture. This course prepares students to make a film by teaching the necessary steps leading up to shooting the film in production. Topics covered include script, proposal, treatment, casting, crew, locations, financing, personnel, permits, unions, and talent. (CSU)

MAD 184 C Digital Video Explorations 3 Units

Term hours: 32–36 lecture and 64–72 laboratory TBA. This course focuses on the use of introductory video and audio programs. The use of various basic video input and output devices will be covered. This course is designed for students to input, create, manipulate and output digital video. This class is intended as a gateway into the varied offerings of the Digital Cinema program, where the student can pursue more in-depth study on the topic(s) that most attracted them during this introductory class. May be taken for credit 3 times. \$20.00 Materials Fee — Payable at Registration. (CSU)

MAD 185 C Documentary Digital Cinema 3 Units

Term hours: 32–36 lecture and 64–72 laboratory TBA. This course provides an introduction to contemporary documentary filmmaking techniques used by digital cinema technicians and artists. May be taken for credit 3 times. Hands-on demonstration and lecture and group activities present technical and artistic approaches to documentary productions. Students participate in individual and group projects to produce documentary films. \$20.00 Material Fee — Payable at Registration. (CSU)

MAD 186 C Wedding and Event Videography 3 Units

Term hours: 32–36 lecture and 64–72 laboratory TBA. This course is designed to introduce the student to the aesthetic concepts, basic skills, and techniques used by videographers to create wedding story films. Students will acquire hands on knowledge of Digital Cinema applications and hardware used in wedding story videography. May be taken for credit 3 times. \$20.00 Material Fee — Payable at Registration. (CSU)

MAD 187 C Motion Graphics II 3 Units

Term hours: 32–36 lecture and 64–72 laboratory TBA. Advanced studies in motion graphics design and software. Topics include both technical and aesthetic issues for motion graphic composition and implementation. Students concentrate on one area to explore in depth and further develop their skills. Production workflow is emphasized. Current trends and styles are discussed. May be taken for credit 3 times. \$20.00 Material Fee — Payable at Registration. (CSU)

MAD 188 C Video Production II 3 Units

Term hours: 32–36 lecture and 64–72 laboratory TBA. This course introduces digital video production techniques including single camera operation and procedures, basic principles and techniques of sound and scriptwriting, and digital video editing. Course topics include the operation of digital camcorders; lighting and sound equipment and post production digital editing suites; concepts and techniques of nonlinear digital editing, including organization of the editing process; working the time line and audio editing, with emphasis on the principles and aesthetics of video editing. May be taken for credit 3 times. \$20.00 Material Fee — Payable at Registration. (CSU)

MAD 189 C Cinematography II **3 Units**

Term hours: 32–36 lecture and 64–72 laboratory TBA. This is an advanced course in digital cinema design and production planning taught through hands-on experience, research and video production. Course topics include digital cinema as a new media tool; synthetic lighting, technological advances in cinematography and emerging tools and techniques. May be taken for credit 3 times. \$20.00 Material Fee — Payable at Registration. (CSU)

MAD 190 C Contemporary Art Studio **3 Units**

Term hours: 32–36 lecture and 64–72 laboratory. This is a course in contemporary art making with a special emphasis on new genres and technology-based media, including projects in digital media, installation, performance, video, interdisciplinary media, and other nontraditional media and processes. The course will include lectures, discussions, field trips, and projects that address contemporary art and technology topics. May be taken for credit 3 times. (UC/CSU)

MAD 191 C Film Noir Genre **3 Units**

Advisory ENGL 100 C.

Term hours: 48–54 lecture. This course is an in depth exploration of Film Noir. The film genre identified by its crime melodramas where private investigators, innocents and deceptive characters live in a world of corruption, betrayal, obsession, intense romantic trysts and sudden violence. Films will be screened from this period in cinema which began in the early 1940s and continued to the late 1950s with echoes of the genre emerging up to the present. Students will be required to obtain and view films from a provided list. (UC/CSU)

MAD 192 C Great Directors of Cinema **3 Units**

Advisory ENGL 100 C.

Term hours: 48–54 lecture. A study of historically and aesthetically important film directors focusing on how their work has advanced and defined the art of cinema. The course will explore various directors in terms of themes, stylistic tendencies including use of cinematography tools and social/historical context. (UC/CSU)

MAD 193 C Introduction to 2D Animation **3 Units**

Term hours: 32–36 lecture and 64–72 laboratory TBA. An introduction to 2D animation production including classical character animation and non-traditional techniques. The class will explore traditionally drawn and emerging digital animation techniques and technology. May be taken for credit 3 times. \$20.00 Materials Fee — Payable at Registration. (CSU)

MAD 195 C Science Fiction Film Genre **3 Units**

Advisory ENGL 100 C.

Term hours: 48–54 Lecture. This course is an in depth exploration of the Science Fiction Film Genre. The genre is identified by speculative science based narratives which may include time travel, aliens, robots and other futuristic elements. Science fiction films have been used to explore political and social issues as well as human condition. A primary focus of this class is the analysis of technical advancements in film production and cinematic techniques and styles present in the genre. Students will be required to obtain and view films from a provided list. (UC/CSU)

MAD 197 C Western Film Genre **3 Units**

Advisory ENGL 100 C.

Term hours 48–54 lecture. This course is an in depth exploration of the Western Film Genre which originated in the United States. The film genre is identified by its heroes and villains struggling for control of the American frontier and conquest over the wilderness. Films will be screened from this period in cinema which began in the silent era and continue to the present. A focus will be placed on the technological advances in film production and cinematic styles that have influenced contemporary films. (UC/CSU)

MAD 199 C Computer Graphics Studio **.5 to 10 Units**

Term hours: 24–540 laboratory depending on units attempted. This course is designed as an open laboratory for students currently enrolled in Fine Arts Division courses that require completion of digital assignments and/or personal digital portfolio development. This open lab with flexible hours is designed to provide students with space, computers, software, scanners, cameras, printers, and internet access. May be taken for a cumulative total of 10 units. Open Entry/Open Exit. Pass/No Pass. (CSU)

MAD 298 C MAD Seminar **.5–12 Units**

Prerequisite: May be required.

Corequisite: May be required.

Advisory: May be required.

Term hours: 0–216 lecture and/or 0–648 laboratory depending on units attempted. Various classes may be offered from semester to semester which are designed to meet the interests and needs of the students. May be taken for credit 1–4 times. Pass/No Pass/Letter Grade Option. Fee: May be required — Payable at Registration. (CSU)

Medicine

MEDICINE TRANSFER PROGRAM

Professional programs such as dentistry, medicine, pharmacy, optometry, physician assistant, physical therapy and veterinary medicine are most often graduate programs that require a bachelor degree or significant preparation prior to entering the program. The appropriate preparation varies according to the school and specific program. Students are advised to meet with a counselor to discuss options for their bachelor degree and the lower division requirements for the program and school of their choice.

Merchandising

Division of Business and Computer Information Systems

Division Dean — Dave Wassenaar

Faculty

Patricia Kishel

Counselor

Robert Grantham

ASSOCIATE IN ARTS DEGREE BUSINESS ADMINISTRATION

Program Code: 1A16599

This curriculum is designed to provide an opportunity for the business major to achieve an Associate in Arts Degree Business Administration while completing the first and second year requirements for transfer to a four-year institution. While a baccalaureate degree is recommended preparation for those considering professional careers in business administration, completion of this curriculum will demonstrate commitment to the field and provide comprehensive preparation for upper-division work.

Students should consult a counselor and the catalog of the individual college or university to plan a program of study. The internet site www.assist.org will also provide information for California public universities. Courses selected to fulfill the requirements of the associate degree should reflect requirements of the college to which the student plans to transfer.

To earn an Associate Degree students must complete: (1) all major course requirements with a minimum grade of “C”; (2) California State University General Education Breadth requirements (CSU GE Breadth) or IGETC General Education Plan; (3) any elective courses to complete a minimum of 60 units; (4) complete all graduation requirements; and, (5) have an overall GPA of 2.0. At least 50% of all major course work must be completed at Cypress College. **Students pursuing more than one specified departmental major may double count a maximum of 7 units to fulfill major requirements.**

Courses that fulfill major requirements for an Associate Degree at Cypress College might not be the same as those required for completing the major at a transfer institution offering a Baccalaureate Degree. For information on specific university requirements, please consult with your counselor, or visit the Transfer Center.

Required courses are listed in suggested sequence:

Course #	Title	Units
MGT 161 C	Introduction to Business	3
CIS 111 C	Computer Information Systems	3
*ECON 100 C	Principles of Economics — Macro or	3
*ECON 100HC	Honors Principles of Economics	(3)
**ECON 105 C	Principles of Economics — Micro or	3
**ECON 105HC	Honors Principles of Economics	(3)
MGT 240 C	Legal Environment of Business or	3
MGT 241 C	Legal Aspects — Business Transactions	(3)
ACCT 101 C	Financial Accounting	4
ACCT 102 C	Managerial Accounting	4
MATH 130 C	Survey of Calculus	4
MKT 222 C	Principles of Marketing	3
Total Units Required		30

Elective:

MGT 211 C	Writing for Business	3
-----------	----------------------	---

*A score of 3 or higher on the Advanced Placement (AP) Economics (macro) exam meets this requirement upon petition through Admissions and Records. See a counselor for more information.

**A score of 3 or higher on the Advanced Placement (AP) Economics (micro) exam meets this requirement upon petition through Admissions and Records. See a counselor for more information.

**ASSOCIATE IN SCIENCE DEGREE
MERCHANDISING Program Code: 1S07814**

This curriculum is designed to prepare students for careers in merchandising and retailing, learning the necessary techniques to display and sell merchandise, satisfy customers and enhance business profitability.

To earn an Associate Degree students must complete: (1) all major course requirements with a minimum grade of “C”; (2) 25 units of General Education Graduation Requirements; (3) the cultural diversity and reading requirement; (4) any elective courses to complete a minimum of 60 units; and, (5) have a minimum GPA of 2.0. At least 50% of all major course work must be completed at Cypress College.

Courses that fulfill major requirements for an Associate Degree at Cypress College might not be the same as those required for completing the major at a transfer institution offering a Baccalaureate Degree. For information on specific university requirements, please consult with your counselor, or visit the Transfer Center.

Required courses are listed in suggested sequence:

Course #	Title	Units
MGT 161 C	Introduction to Business	3
MKT 210 C	Consumer Behavior	3
MKT 103 C	Principles of Advertising	3
MKT 208 C	Principles of Selling	3
MKT 222 C	Principles of Marketing	3
MKT 105 C	Principles of Retailing	3
MGT 266 C	Human Relations in Business	3
Total Units Required		21

Electives

MGT 151 C	Business Mathematics	3
WKEX 191 C	Work Experience — Vocational	4–16
MGT 261 C	Small Business Management	3
MGT 265 C	Social Responsibility of Business	3
MGT 041 C	Survey of Business Law	3

**MERCHANDISING
CERTIFICATE Program Code: 1C21009**

Primary emphasis is to prepare the student to work in the merchandising and retailing field with a focus on building positive customer relationships. To earn a certificate, students must complete the required courses as listed with a minimum grade of “C.” At least 50% of all course work must be completed at Cypress College.

Required courses are listed in suggested sequence:

Course #	Title	Units
MGT 161 C	Introduction to Business	3
MKT 208 C	Principles of Selling	3
MKT 105 C	Principles of Retailing	3
MKT 210 C	Consumer Behavior	3
MKT 222 C	Principles of Marketing	3
MKT 103 C	Principle of Advertising	3
MGT 266 C	Human Relations in Business	3
Total Units Required		21

**MERCHANDISING TRANSFER PROGRAM
Refer to Catalog under
BUSINESS ADMINISTRATION TRANSFER PROGRAM**

Students should consult a counselor or www.assist.org for lower division major requirements for most California public universities. (See the Standard Definitions section of the catalog for a description of ASSIST.) Students transferring to an independent college/university should consult the catalog of the individual school and a counselor for lower division major requirements.

Mortuary Science

Division of Health Science

Division Dean — John Sciacca

Faculty

Kathleen Boettger

Glenn Bower

Jolena Grande

Dave McCament

Counselors

Kelly Carter

Denise Vo

PROGRAM LEARNING OUTCOMES (PLOs)

Mortuary Science

A student who completes the Mortuary Science program will be able to:

- Enlarge the background and knowledge of students desiring to enter the funeral service profession.
- Educate students in every phase of funeral service, and to help them to develop proficiency and skills necessary for the profession.
- Educate students concerning the responsibilities of the funeral service profession to the community at large.
- Emphasize high standards of ethical conduct.
- Provide a curriculum at the post secondary level of instruction.
- Encourage student and faculty research in the field of funeral service.
- Qualify students for professional licensure examination.

Mortuary Science Program Aims

The Mortuary Science Program at Cypress College has as its central aim recognition of the importance of funeral service education personnel as:

1. Members of a human services profession;
2. Members of the community in which they serve;
3. Participants in the relationship between bereaved families and those engaged in the funeral service profession;
4. Professionals knowledgeable of and compliant with federal, state, provincial/territorial and local regulatory guidelines in the geographic area where they practice; as well as
5. Professionals sensitive to the responsibility for public health, safety and welfare in caring for human remains.

MORTUARY SCIENCE PROGRAM OBJECTIVES

1. To enlarge the background and knowledge of students about the funeral service profession;
2. To educate students in every phase of funeral service, and to help enable them to develop the proficiency and skills necessary in the profession, as defined in the Preamble at the beginning of Chapter 9 of the Manual on Accreditation;
3. To educate students concerning the responsibilities of the funeral service profession to the community at large;
4. To emphasize high standards of ethical conduct;
5. To provide a curriculum at the post secondary level of instruction;
6. To encourage student and faculty research in the field of funeral service; and
7. To qualify students for professional licensure examinations.

MINIMUM STANDARDS FOR APPLICANTS

1. Eligibility for admission to Cypress College.
2. Official High school transcripts, a GED test with a minimum score of 450 on the five-test battery, or high school proficiency examination.
3. Present evidence of good physical and mental health.
4. English Placement Test with a score to qualify for ENGL 100 C or completion of ENGL 060 C with the grade of "C" or better or ESL 186 C with a grade of "C" or better.
5. One semester of college general or human biology, anatomy, or introductory chemistry completed with a cumulative grade of "C" or better.
6. A minimum GPA of 2.0 in all college courses attempted.

Remember, this is a **full time program**. All general education graduation requirements need to be completed prior to applying to the program.

APPLICATION PROCEDURES

1. In addition to the Cypress College application form, a separate application is required for admission into the Mortuary Science Program. Applications must be completed **online**. Please see the **Health Science Application link** on the Mortuary Science home page.
2. A total of 30 new students are selected each spring and fall semester. Applicants may exceed the available seat space. Prioritization of qualified applicants will determine acceptance.
3. Applicants are responsible for submitting all documents (records, forms and transcripts) indicating minimum standards and prerequisites have been met to the Health Science Counseling Office.

SELECTION PROCEDURES

Selection of students for acceptance is based on the **date** of completed application which includes submission of **all** transcripts and required documents. In addition, starting Fall 2013 students will be selected using a point system based on the number of general education/graduation courses completed at the time of application.

**ASSOCIATE IN SCIENCE DEGREE
MORTUARY SCIENCE Program Code: 1S03791**

This program is a course of study designed for students who wish to prepare for a career and employment as an embalmer/funeral director in a mortuary and to prepare the student for state licensure where statutory law requires successful completion of the Associate in Science Degree in Mortuary Science and compliance with statutory pre-mortuary science educational requirements. All students completing the Mortuary Science Program curriculum after January 1, 2006, must complete the Associate of Science Degree in Mortuary Science. The Mortuary Science Program at Cypress College is accredited by the American Board of Funeral Service Education (ABFSE), 3414 Ashland Avenue, Suite G, St. Joseph, MO 64506, (816) 233-3747, www.abfse.org, and meets the mortuary science or funeral service educational requirements for most states. Eligibility to write the licensure examination in some states may be contingent upon compliance with additional statutory requirements. Please consult the department for more specific information, or, for further information, contact a Health Science Counselor (714) 484-7270. To earn an Associate Degree students must complete: (1) all major course requirements with a minimum grade of "C" or better; (2) 25 units of General Education Graduation Requirements with a minimum grade of "C"; (3) take the National Board Examination (This policy supercedes all previous catalogs — students need to submit National Board Examination results to Admissions and Records no later than the date listed for "Final Transcript for In-Progress Work" for the semester the student is applying); (4) the cultural diversity and reading requirements with a minimum grade of "C"; (5) any elective courses to complete a minimum of 60 units; and, (6) have a minimum GPA of 2.0. At least 50% of all major course work must be completed at Cypress College.

To be eligible to write the National Board Examination, the student must be within 45 days of completing the Associate in Science Degree in Mortuary Science. We recommend the general education graduation requirements be taken prior to enrolling in Mortuary Science courses so that the student can write the examination immediately upon completion of the mortuary science curriculum.

The annual passage rate of first-time takers on the National Board Examination (NBE) for the most recent three-year period for this institution and all ABFSE accredited funeral service education programs is posted on the ABFSE web site (www.abfse.org).

National Board Exam Statistics			
Year	No. of Takers	No. Who Passed	% Who Passed
2008	32	28	88%
2009	33	28	88%
2010 Arts	34	32	94%
2010 Science	34	34	100%
2011 Arts	37	35	95%
2011 Science	38	33	87%

Prerequisites		
BIOL 160 C	Integrated Medical Science	3
	or	
*BIOL 101 C	General Biology	(5)
	or	
CHEM	Various courses — Please see counselor	
ENGL 060 C	College Writing Preparation	3
	or	
ESL 186 C	Advanced ESL Writing	(5)
	See minimum standards	

Required courses are listed in suggested sequence:

Course #	Title	Units
SEMESTER 1		
MORT 160 C	Orientation to Funeral Service	3
MORT 163 C	Embalming Anatomy/Pathology I	4
MORT 164 C	Funeral Service Thanatology I	2
MORT 165 C	Funeral Service Management I	3
MORT 170 C	Funeral Service Ceremonies	3
		<hr/>
		15
SEMESTER 2		
MORT 261 C	Restorative Art I	2
MORT 262 C	Embalming I	3
MORT 263 C	Embalming Anatomy/Pathology II	4
MORT 265 C	Funeral Service Management II	3
MORT 274 C	Funeral Service Thanatology II	3
MORT 275 C	Mortuary Law I	3
		<hr/>
		18
SEMESTER 3		
MORT 271 C	Restorative Art II	2
MORT 272 C	Embalming II	3
MORT 285 C	Mortuary Law II	3
MORT 292 C	Funeral Service Science	3
MORT 293 C	Mortuary Computer Applications	2
MORT 294 C	Funeral Service Counseling	4
		<hr/>
		17
	Total Units Required	<hr/> 50
GENERAL EDUCATION GRADUATION REQUIREMENTS		
	Categories A through E (see listing earlier in catalog)	25
	Cultural Diversity/Reading Proficiency	
	Total Units Required	<hr/> 75

*A score of 3 or higher on the Advanced Placement (AP) Biology exam meets this requirement upon petition through Admissions and Records. See a counselor for more information.

Mortuary Science (MORT)

MORT 085 C Work Experience 1 to 4 Units

Prerequisite: Admission to Mortuary Science Program. Must be enrolled in seven units or more in the Mortuary Science Program, including work experience.

Term hours: 16–18 lecture and 80–360 related employment in an approved funeral establishment. This course focuses on exploring work related issues in a funeral establishment of the student's own selection. Discussion of funeral service business and related technical issues are explored. The course includes job analysis, writing a resume, self-management, self-development and employer-employee relations. May be taken for credit 4 times.

MORT 160 C Orientation to Funeral Service 3 Units*Prerequisite: Admission to Mortuary Science Program.*

Term hours: 48–54 lecture. This course is designed to acquaint the mortuary science student with general information on the practice of the funeral profession. Topics covered include: notification of death, transfer of remains, the arrangement conference, prefunded/preplanned funerals, shipment of remains, cremation, and aftercare, as well as the basic principles of merchandising as it applies to the funeral profession, construction and features of caskets, outer burial containers, and other funeral related products; and methods of display and presentation. In addition, the progression of associations and education within funeral service will be discussed. (CSU)

MORT 163 C Embalming Anatomy/Pathology I 4 Units*Prerequisite: Admission to Mortuary Science Program.*

Term hours: 64–72 lecture. This introductory course is designed for the mortuary science student, surveys general anatomical, physiological and pathological concepts processes and terminology important to the funeral service practitioner in understanding the embalming process, articulating with allied health/forensic professionals, interpreting death certificates and protecting oneself and the public against communicable disease. Also considered are those medical and forensic pathologies presenting particular embalming and restorative problems. (CSU)

MORT 164 C Funeral Service Thanatology I 2 Units*Prerequisite: Completion of or concurrent enrollment in MORT 160 C.*

Term hours: 32–36 lecture. This course is an introduction to thanatology, basic psychological terminology and theories. Emphasis is on the study of grief, bereavement, and mourning. The content provides the knowledge required of the funeral director to work effectively with families as a facilitating agent. The needs of the families served are studied in relation to the design and implementation of the funeral rite. (CSU)

MORT 165 C Funeral Service Management I 3 Units*Prerequisite: Completion of, or concurrent enrollment in MORT 160 C.*

Term hours: 32–36 lecture and 48–54 laboratory. Designed for the mortuary science student, the course is a vocationally oriented survey of funeral service management as it applies to funeral home operations, mortuary management, and financial decision-making. Information presented covers financial statements and their analysis, worksheets, journalizing, receivables, payables, deferrals, and accruals. Inventory costing models, depreciation models, and funeral service payroll accounts are also included. (CSU)

MORT 170 C Funeral Service Ceremonies 3 Units*Prerequisite: Completion of or concurrent enrollment in MORT 160 C.*

Term hours 48–54 lecture. This course is designed to introduce the student to American funeral service practices and procedures in military, fraternal and religious funerals for a complete understanding of all principles and variations involved. (CSU)

MORT 261 C Restorative Art I 2 Units*Prerequisite: Completion of or concurrent enrollment in MORT 263 C.*

Term hours: 16–18 lecture and 48–54 laboratory. A detailed study is made of each of the facial features and its relationship to a complete restoration. In the laboratory the student has an opportunity to follow through with the modeling in clay of the features studied, both as a single feature and using plaster of Paris heads for reproduction. (CSU)

MORT 262 C Embalming I 3 Units*Prerequisite: Completion of or concurrent enrollment in MORT 263 C.*

Term hours: 32–36 lecture and 48–54 laboratory. This course is designed to include basic orientation, history of embalming to present times, moral and sanitary considerations of embalming, methods of handling human remains, including those of a contagious or infectious nature, demonstration of the various methods of preparation and disinfection treatment of bodies contaminated by radiation. (CSU)

MORT 263 C Embalming Anatomy/Pathology II 4 Units*Prerequisite: MORT 163 C.*

Term hours: 64–72 lecture. Designed for the Mortuary Science student, and a continuation of MORT 163 C, the course surveys general anatomical, physiological, and pathological concepts as they relate to the various systems of the human body. The body systems are studied in detail as they relate to preservation and disinfection for safeguard measures in handling and embalming of human remains to protect public health and the embalmer. Throughout the course, terminology is emphasized to facilitate interpretation of death certificates. (CSU)

MORT 265 C Funeral Service Management II 3 Units*Prerequisite: MORT 160 C and MORT 165 C.*

Term hours: 48–54 lecture. This course is a continuation of MORT 165 C designed to introduce the mortuary science student to the basic principles of management, merchandising, and effective managerial skills as they apply to the practice of the funeral profession; to the financial aspects of funeral business operation, concepts of financial management and the use of financial information in decision-making relative to cost analysis and control, pricing, inventory and in assessing the firm's performance; and credit policies and practices. (CSU)

MORT 271 C Restorative Art II 2 Units*Prerequisite: MORT 261 C and MORT 263 C.*

Term hours: 16–18 lecture and 48–54 laboratory. This is a continuation of MORT 261 C, with emphasis upon major restorations and explains how all previous restorative art work can be used to complete each type of case. Color theory and cosmetology are discussed. In the lab the student will perform feature modeling in wax on both plaster of Paris and latex heads. In addition there is practical work in cosmetics, hair dressing, color pigments and preparation of death masks. (CSU)

MORT 272 C Embalming II 3 Units*Prerequisite: MORT 262 C and MORT 263 C.*

Term hours: 32–36 lecture and 48–54 laboratory. This is a continuation of MORT 262 C, with emphasis upon the development of embalming techniques, dead human remains having various diseases, treatment of localized areas by supplemental methods of preservation and the application of embalming theories ranging from pre-embalming analysis to funeral home visitation room appearance, in a laboratory environment. (CSU)

MORT 274 C Funeral Service Thanatology II 3 Units*Prerequisite: MORT 160 C and MORT 164 C and MORT 170 C.*

Term hours: 48–54 lecture. This course is a continuation of MORT 164 C, with emphasis on the grief process, normal and abnormal, and the resolution of grief. Follow-up programs initiated by the funeral director are examined in detail as well as community support groups with whom the funeral director participates. Major emphasis is placed on the student identifying problem areas in the field, making a plan for intervention, and making appropriate referrals to community professionals. (CSU)

MORT 275 C Mortuary Law I

3 Units

Prerequisite: MORT 160 C and completion of or concurrent enrollment in MORT 265 C.

Term hours: 48–54 lecture. This course designed for the Mortuary Science student, surveys the American legal system, its development, and the major bodies of law as they relate to the legal environment in which the funeral business operates. The legal aspects of funeral service contracts, funeral service sales, and the use of commercial paper are also considered. This course will also look at the professional ethics used by funeral service providers as it relates to the legal aspects of the funeral home establishment. (CSU)

MORT 285 C Mortuary Law II

3 Units

Prerequisite: MORT 265 C and MORT 275 C.

Term hours: 48–54 lecture. This course is a continuation of MORT 275 C designed to introduce the mortuary science student to sources of law, legal status of the dead human body, duty of burial, right to control funeral arrangements, final disposition, and liability for funeral expenses; torts involving the dead human body and the funeral director; wills, estate, and probate proceedings; cemeteries and related issues; state and federal laws and regulations pertaining to funeral service; as well as the legal aspects of being a licensed funeral director/mortician. (CSU)

MORT 292 C Funeral Service Science

3 Units

Prerequisite: Completion of or concurrent enrollment in MORT 272 C.

Term hours: 48–54 lecture. This course is designed to familiarize the Mortuary Science student with the nature of chemicals utilized in the mortuary setting, and to provide a qualitative understanding of the chemical aspects of tissue decomposition and preservation. Embalming of protein and the effects relative to the blood, body pigments and tissue staining are a primary emphasis of the course. (CSU)

MORT 293 C Mortuary Computer Applications

2 Units

Prerequisite: Completion of all required general education courses and graduation requirements for the Associate in Science Degree Mortuary Science.

Term hours: 16–18 lecture and 48–54 laboratory. The course is designed to provide the mortuary science student with an overview of considerations relevant to the operation of the funeral home as a small business through the use of hands-on experience with appropriate mortuary science computer software, as well as the Federal Trade Commission Funeral Rule. \$96.00 Material Fee — Payable at Registration. (CSU)

MORT 294 C Funeral Service Counseling

4 Units

Prerequisite: MORT 274 C.

Term hours: 64–72 lecture. This is a course aimed at the study of concepts, techniques and procedures used by the funeral director in his/her role as a counselor. (CSU)

**Motorcycle Technology —
See Automotive Technology (AT)**

Multimedia

Division of Fine Arts

Division Dean — Ting-Pi (Joyce) Carrigan

Faculty

- Barbara Braden Meyer
- Joe Gallo
- Edward Giardina
- Ian Holmes
- Michael Johnson
- Robert Johnson
- Clifford Lester
- Robert Mercer

Counselors

- Renay Laguana-Ferinac
- Renee Ssensalo

**MULTIMEDIA ART
CERTIFICATE**

Program Code: 1C12359

The Multimedia Art Certificate Program provides the skills necessary to create interactive projects for distribution on videotape, CD-ROMs, and Web sites.

To earn a certificate, students must complete the required major courses as listed with a minimum grade of “C” for each course. At least 50% of all course work must be completed at Cypress College.

Required courses are listed in suggested sequence:

Course #	Title	Units
MM 100 C	Introduction to Multimedia	3
MM 110 C	Visual Communications	3
PHOT 101 C	Introduction to Photography	3
ART 120 C	Two-Dimensional Design	3
MUS 124 C	Recording Studio I	3
	or	
MUS 178 C	Digital Music Technology	(3)
MAD 100 C	Intro to Computer Graphics/Mac	3
	or	
MAD 101 C	Intro to Computer Graphics/Win	(3)
	or	
MAD 102 C	Intro to Mac Web Graphics	(3)
	or	
MAD 103 C	Intro to Win Web Graphics	(3)
MAD 134 C	Digital Imaging/Mac	3
	or	
MAD 135 C	Digital Imaging/Win	(3)
MAD 162 C	Multimedia Web Design/Mac	3
	or	
MAD 163 C	Multimedia/Win	(3)
MAD 164 C	Adobe Flash Designer/Mac	3
	or	
MAD 165 C	Adobe Flash Designer/Win	(3)
	Total Units Required	27

MULTIMEDIA PHOTOGRAPHY**CERTIFICATE****Program Code: 1C13043**

This certificate is designed to prepare the student to work with a variety of photographically based digital applications within the field of Multimedia. This flexible module allows the student to develop their own emphasis within the possible course offerings.

To earn a certificate, students must complete the required major courses as listed with a minimum grade of “C” for each course. At least 50% of all course work must be completed at Cypress College.

Required courses are listed in suggested sequence:

Course #	Title	Units
MM 100 C	Introduction to Multimedia	3
MM 110 C	Visual Communications	3
PHOT 101 C	Introduction to Photography	3
PHOT 103 C	Photographic Possibilities	3
PHOT 207 C	Color Photography	3
PHOT 208 C	Advanced Color Photography	3
PHOT 209 C	Careers in Photography	3
PHOT 215 C	Digital Photography	3
PHOT 216 C	Advanced Digital Photography	3
PHOT 217 C	3D Photo Imaging	3
Total Units Required		30

Any one of the following may be substituted for the above except PHOT 103 C, PHOT 215 C, PHOT 207 C because these are prerequisite courses:

PHOT 050 C	Photography Special Projects (This is a portfolio class)	3
PHOT 104 C	Wedding Photography	3
PHOT 109 C	Portrait Photography	3
PHOT 200 C	Conceptual Photography	3
PHOT 219 C	Photography for Publication	3

MULTIMEDIA ADVERTISING**CERTIFICATE Program Code: Pending State Approval**

The certificate program will enable students to apply multimedia production skills and knowledge in such areas as Internet, computer imaging, photography, art and music to careers in the field of advertising, developing promotional materials to communicate with customers.

To earn a certificate, students must complete the required courses as listed with a minimum grade of “C.” At least 50% of all course work must be completed at Cypress College.

Required courses are listed in suggested sequence:

Course#	Title	Units
MM 100 C	Introduction to Multimedia	3
MM 110 C	Visual Communication	3
PHOT 101 C	Introduction to Photography	3
MKT 103 C	Principles of Advertising	3
MKT 222 C	Principles of Marketing	3
CIS 115 C	Desktop Publishing — Publisher	1
	or	
CIS 179 C	Intro. to Web Page Design	(3)
Total Units Required		16–18

Multimedia (MM)**MM 100 C Introduction to Multimedia****3 Units**

Term hours: 48–54 lecture. This class is designed to introduce the student to the various disciplines involved in the creation of multimedia products. These disciplines include information systems, computer graphics and visual design, digital photography, electronic music, digital journalism and video. (CSU)

MM 101 C Introduction to Online Learning**1 Unit**

Term hours: 16–18 lecture. This course prepares the student for the online education experience through direct application of online courseware tools such as chat, discussion, file exchange, homepage, course calendar, online gradebook, and external links. It also explores word processing basics, time management, troubleshooting, electronic mail, email attachments, Internet navigation and research, file transfer protocol and other Internet services. Pass/No Pass/Letter Grade Option. (CSU)

MM 110 C Visual Communication**3 Units**

Term hours: 48–54 lecture. An introduction to the concepts and techniques of visual perception, color and design using graphic, photographic and video images, with the computer as a tool, for multimedia production. Emphasis is on thinking processes and problem solving basic to creative visual work. (UC/CSU)

Music**Division of Fine Arts**

Division Dean — Ting-Pi (Joyce) Carrigan

Faculty

George Beyer
Helena DeCoro
Joe Gallo
Kathryn Reid

Counselors

Renay Laguana-Ferinac
Renee Ssensalo

PROGRAM LEARNING OUTCOMES (PLOs)

The courses taught by this department contribute to the General Education and Basic Skills Program Learning Outcomes. Please refer to General Education and Basic Skills Program Learning Outcomes.

Music Department

- Given a variety of music materials and subject matter, students will be able to critically analyze the content and creation through composition, process, and music historical context.
- Given a variety of music materials and subject matter, students will be able to discuss the content and creation of music, through composition, process, and music historical context.
- Given a variety of music materials and subject matter, students will be able to identify the content and creation through composition, process, and music historical context.
- Given a variety of music materials and subject matter, students will be able to personalize the social and psychological aspects of the content and creation through composition, process and music historical context.

COMMERCIAL MUSIC — MANAGEMENT CERTIFICATE **Program Code: 1K12951**

A synthesis of Music and Business courses, this certificate enables students to develop the management, marketing, and entrepreneurial skills necessary for success in the Music Industry.

To earn a certificate, students must complete the required courses as listed with a minimum grade of “C.” At least 50% of all course work must be completed at Cypress College.

Required courses are listed in suggested sequence:

Course #	Title	Units
MUS 111 C	The Music Business	3
MUS 212 C	Music Promotion and Distribution	3
MKT 222 C	Principles of Marketing	3
MGT 261 C	Small Business Management	3
MGT 266 C	Human Relations in Business	3
Total Units Required		15

Recommended Electives

MKT 224 C	International Marketing	(3)
-----------	-------------------------	-----

ASSOCIATE IN ARTS DEGREE MUSIC **Program Code: 1A03777**

The Associate in Arts Degree in Music is designed to prepare the student for a career as a professional musician. This curriculum includes music history and theory, as well as applied instruction and performance experience on his or her particular instrument.

To earn an Associate Degree students must complete: (1) all major course requirements with a minimum grade of “C”; (2) 25 units of General Education Graduation Requirements; (3) the cultural diversity and reading requirements; (4) any elective courses to complete a minimum of 60 units; and, (5) have a minimum GPA of 2.0. At least 50% of all major course work must be completed at Cypress College. Courses that fulfill major requirements for an Associate Degree at Cypress College might not be the same as those required for completing the major at a transfer institution offering a Baccalaureate Degree. For information on specific university requirements, please consult with your counselor, or visit the Transfer Center.

Required courses are listed in suggested sequence:

Course #	Title	Units
MUS 101 C	Music Fundamentals	3
*MUS 103AC	Theory and Musicianship I	4
*MUS 103BC	Theory and Musicianship II	4
MUS 108 C	Intro to Music Technology	3
MUS 120 C	Survey of Music History	3
	or	
MUS 116 C	Music Appreciation	(3)
MUS 122 C	Concert Hour	1,1,1,1
MUS 135 C	Beginning Piano	1,1
MUS 236 C	Intermediate Piano	1,1
MUS 225 C	Applied Music	1,1,1,1

Select a minimum of 1 unit each semester from the following performing ensembles for a total of 4 units:

Course #	Title	Units
MUS 175 C	Swing Band	1,1,1,1
MUS 260 C	Classical Guitar Ensemble	1,1,1,1
MUS 273 C	Concert Band	1,1,1,1
MUS 274 C	Cypress Symphonic Winds	1,1,1,1
MUS 276 C	Jazz Band	1,1,1,1
MUS 277 C	Jazz Lab Band	1,1,1,1
MUS 280 C	Jazz/Musical Theater Choir	1,1,1,1
MUS 281 C	Concert Choir	1,1,1,1
MUS 282 C	Cypress Masterworks Chorale	1,1,1,1
MUS 283 C	Cypress Singers	1,1,1,1
MUS 285 C	Chamber Singers	1,1,1,1
MUS 287 C	Vocal Jazz Ensemble	1,1,1,1
Total Units		33

*A score of 3 or higher on the Advanced Placement (AP) Music Theory exam meets this requirement upon petition through Admissions and Records. See a counselor for more information.

RECORDING ARTS CERTIFICATE **Program Code: 1K12958**

This program was developed for prospective record producers, recording engineers, and songwriters, giving an insider’s look at the way music is recorded today. Students will gain hands-on experience in “state of the art” facilities.

To earn a certificate, students must complete the required courses as listed with a minimum grade of “C.” At least 50% of all course work must be completed at Cypress College.

Required courses are listed in suggested sequence:

Course #	Title	Units
MUS 101 C	Music Fundamentals	3
MUS 108 C	Intro to Music Technology	3
MUS 124 C	Recording Studio I	3
MUS 176 C	Popular Songwriting	3
	or	
MUS 177 C	Songwriting Workshop	(3)
MUS 222 C	Audio Production for Film I	3
Total Units Required		15

MUSIC TRANSFER PROGRAM

Students should consult a counselor or www.assist.org for lower division major requirements for most California public universities. (See the Standard Definitions section of the catalog for a description of ASSIST.) Students transferring to an independent college/university should consult the catalog of the individual school and a counselor for lower division major requirements.

Music (MUS)

MUS 101 C Music Fundamentals 3 Units

Term hours: 48–54. This cross cultural course covers the elements of sound, their application and effect in musical structures. The historical evolution of music, notation, and its understanding and application are presented in an international societal context. It is open to all students. Note: No UC credit if taken after MUS 103AC. (UC Credit Limitation/CSU, AA GE, CSU GE)

MUS 102 C Music Reading 3 Units

Term hours: 48–54 lecture. This course is designed to teach students how to read music from the printed page. Participants will learn basic skills, such as identifying note names and rhythm values, and will progress to the primary levels of sight-singing and developing the inner ear, a skill vital to every musician. (UC/CSU)

MUS 103AC Theory and Musicianship I 4 Units

Prerequisite: MUS 101 C or MUS 102 C.

Advisory: Must be concurrently enrolled in a piano class or pass a piano proficiency by audition.

Term hours: 80–90 lecture and 16–18 laboratory. This is the first course in music theory for music majors. Topics include basic terminology, rhythmic and pitch notation, diatonic scales and triads, intervals, chord progressions and basic cadential formulas, seventh chords, figured bass, four-part writing, non-harmonic tones, sight-singing, and melodic, harmonic, and rhythmic dictation. (UC/CSU, AA GE, CSU GE, IGETC)

MUS 103BC Theory and Musicianship II 4 Units

Prerequisite: MUS 101 C.

Term hours: 80–90 lecture and 16–18 laboratory. This course follows MUS 103AC in the music theory sequence. It includes altered non-harmonic tones, and secondary dominants, modulation to closely related keys, borrowed chords, augmented sixth chords, the Neapolitan sixth, and altered dominants. Studies will include modulation to foreign keys, ninth, eleventh, and thirteenth chords and two and three part song form. (UC/CSU)

MUS 108 C Introduction to Music Technology 3 Units

Term hours: 32–36 lecture and 64–72 laboratory. This course covers the following basic aspects of music technology: computer skills, software-based sequencing, synthesis, MIDI, sampling, notation, principles of sound, microphones, introduction to digital audio, signal processing, mixers and mixing, recording principles, cables and interconnects, and audio in live performance. Pass/No Pass/Letter Grade Option. (CSU)

MUS 111 C The Music Business 3 Units

Term hours: 48–54 lecture. From copyrights to contracts, this course covers the essential elements of the music industry for performers, songwriters, producers, and managers. Topics include intellectual property law (copyrights), management contracts, publishing companies, performance rights societies, licensing procedures, record manufacturing and distribution, and an overall look at the dynamics of the music and entertainment industries. Guest speakers will appear according to availability. (CSU)

MUS 113 C Jazz History 3 Units

Term hours: 48–54 lecture. This is a survey course which traces the history and development of jazz music from its inception to the present day. The music, both live and from recordings, is studied from a cultural, musical, historical, and sociological standpoint. Concert attendance is required. Open to all students. Pass/No Pass/Letter Grade Option. (UC/CSU, AA GE, CSU GE, IGETC, CUL DIV)

MUS 116 C Music Appreciation 3 Units

Term hours: 48–54 lecture. A survey of music literature from the Middle Ages to the present. Students will gain an understanding of music as an art form through listening and discussion of choral, orchestral, solo, opera, chamber and jazz works. Concert attendance is required. Open to all students, but designed for the non-music major. Pass/No Pass/Letter Grade Option. (UC/CSU, AA GE, CSU GE, IGETC)

MUS 117 C American Popular Music 3 Units

Term hours: 48–54 lecture. A historical and musical study of American popular music from its origin to the present. The primary focus will be on musical styles with secondary emphasis on sociological, political and economic conditions which influenced the music of America. Concert attendance required. Pass/No Pass/Letter Grade Option. (UC/CSU, AA GE, CSU GE, IGETC)

MUS 118 C Introduction to Opera 3 Units

Term hours: 48–54 lecture. This course is an introduction to the standard operatic repertoire in terms of development of musical style, dramatic structure, and performance tradition. Emphasis is on elements of the art of operatic singing, voice classification, vocal range and technique, and dramatic values. Opportunities for attendance at operatic performances will be provided. Cost of music concert will not exceed \$30.00. Duplicate credit not granted for MUS 118HC. Pass/No Pass/Letter Grade Option. (UC Credit Limitation/CSU, AA GE, CSU GE, IGETC)

MUS 118HC Honors Introduction to Opera 3 Units

Term hours: 48–54 lecture. This course offers an Introduction to Opera course enhanced for honors students in a seminar type setting. Students will survey the standard operatic repertoire in terms of development of musical style, dramatic structure and performance tradition with emphasis on the appreciation of the art of operatic singing, voice classification, vocal technique and dramatic values. Opportunities for field trips and seminars with performers and directors are included. Cost of music concert will not exceed \$30.00. Duplicate credit not granted for MUS 118 C. (UC Credit Limitation/CSU, AA GE, CSU GE, IGETC)

MUS 119 C History of Rock Music 3 Units

Term hours: 48–54 lecture. From its earliest beginnings to the present day, this course surveys the inception, evolution, and development of Rock music in America and abroad. In addition to in-depth studies of Rock music and the artists who created it, students will examine the sociological, political, and economic conditions which influence its development. Pass/No Pass/Letter Grade Option. (UC/CSU, AA GE, CSU GE, IGETC)

MUS 120 C Survey of Music History 3 Units

Term hours: 48–54 lecture. This course is designed for music majors or non-majors with some musical background. Students will study Western stylistical trends, major forms and theory from antiquity to the present. Recordings, videotapes, and live musical performances are used to emphasize material covered in class discussions. (UC/CSU, AA GE, CSU GE, IGETC)

MUS 122 C Concert Hour 1 Unit

Term hours: 16–18 lecture. The concert hour is set aside for on-campus concerts and recitals. A variety of soloists and ensembles will perform music of many styles from the sixteenth century to the present. Students will have an opportunity to observe, listen and discuss with the performers the characteristics of various musical styles and performance techniques. Open to all students. May be taken for credit 4 times. (CSU, AA GE, CSU GE)

MUS 124 C Recording Studio I 3 Units

Term hours: 32–36 lecture and 64–72 laboratory. This class covers the fundamental concepts in audio recording technology. Topics include studio business practices, microphones, mixers, signal processors, the sound field, monitors, recording and editing devices, and synchronization. (CSU)

MUS 126 C Beginning Voice **1 Unit**

Term hours: 16–18 lecture and 16–18 laboratory. Students will study basic vocal techniques including tone production, breath control, and diction. Songs will be drawn from popular and traditional song literature. May be taken for credit 2 times. Pass/No Pass/Letter Grade Option. (UC/CSU, CSU GE)

MUS 127 C Music in Film **3 Units**

Term hours: 48–54 lecture. The class traces the history and development of film music through reading, lecture and film viewing. The class studies the process of film scoring and how music and its relationship to film have changed over the last century. Class includes discussion and evaluation of different compositional styles and learning to listen critically to film scores while viewing movies. Pass/No Pass/Letter Grade Option. (UC/CSU)

MUS 130 C Beginning Guitar **1 Unit**

Term hours: 16–18 lecture and 16–18 laboratory. This course introduces the basics of guitar playing to those with little or no previous experience. Basic technique, playing chords and melodies, and music reading are all covered in detail. Open to all students. May be taken for credit 2 times. Pass/No Pass/Letter Grade Option. (UC/CSU, CSU GE)

MUS 131 C Electric Bass **1 Unit**

Term hours: 16–18 lecture and 16–18 laboratory. This course uses group instruction to teach general techniques for the electric bass guitar. Blues, R&B, rock, pop and jazz styles are emphasized. May be taken for credit 4 times. Pass/No Pass/Letter Grade Option. (UC/CSU)

MUS 135 C Beginning Piano **1 Unit**

Term hours: 16–18 lecture and 16–18 laboratory. This course is a study of basic piano techniques in a class situation. Includes functional use of basic chordal and scale material, reading music notation and rhythms, and presentation of elementary piano study as a basis for lifelong growth in music as art. Required of music majors whose piano skills are non-existent or very limited. Open to all students. May be taken for credit 2 times. Pass/No Pass/Letter Grade Option. (UC/CSU, CSU GE)

MUS 143 C Beginning Strings **1 Unit**

Term hours: 16–18 lecture and 16–18 laboratory. This course teaches the fundamental of string playing for anyone interested in learning to play the violin, viola, violoncello, or string bass. Students must supply their own instruments. Open to all students, no previous experience necessary. May be taken for credit 4 times. (UC/CSU, CSU GE)

MUS 146 C Woodwind Class **1 Unit**

Term hours: 16–18 lecture and 16–18 laboratory. This is a course for students who wish to play flute, oboe, clarinet, bassoon, or saxophone. Students must supply their own instruments. Open to all students, no previous experience necessary. May be taken for credit 4 times. (UC/CSU, CSU GE)

MUS 152 C Percussion Class **1 Unit**

Term hours: 16–18 lecture and 16–18 laboratory. This is a course for students who wish to play drums, timpani, mallet instruments, and other percussion instruments. The class will emphasize basic music reading and rhythmical accuracy. Open to all students, no previous experience necessary. May be taken for credit 4 times. Pass/No Pass/Letter Grade Option. (UC/CSU)

MUS 156 C Jazz Improvisation — Instrumental **1 Unit**

Prerequisite: Audition to evaluate and assess the student's qualifications (proficiency) is required for enrollment.

Term hours: 16–18 lecture and 32–36 laboratory. This class provides intermediate level instrumental students with the tools and techniques for jazz improvisation. Analysis of harmonic and melodic materials, extensive listening, and performance exercises will assist the student in his/her development as an improviser. May be taken for credit 4 times. (UC/CSU)

MUS 157 C Jazz Improvisation — Vocal **1 Unit**

Term hours: 16–18 lecture and 16–18 laboratory. This course offers vocal students training in jazz song-styling techniques focusing on swing, ballad, Latin, blues, and contemporary styles. Topics include rhythmic and melodic improvisation, microphone technique, and scat singing. May be taken for credit 4 times. (UC/CSU)

MUS 175 C Swing Band **1 Unit**

Prerequisite: Audition.

Term hours: 48–54 rehearsal and 20–23 hours of sectional rehearsals, recording, program production and/or concerts. Students in this class will be involved in the rehearsal and concert performance of swing music in the style of the “Big Band Era” from the 1930s to 1950s. May be taken for credit 4 times. (UC/CSU)

MUS 176 C Popular Songwriting **3 Units**

Advisory: MUS 101 C or MUS 103AC.

Advisory: Concurrent enrollment in MUS 238 C.

Term hours: 48–54 lecture. This is an introductory to intermediate course in popular songwriting. Students will learn keyboard skills and notation. They will analyze melody, harmony, song form, rhythm, and lyrics as they apply to popular music. Emphasis will be placed on original compositions and composition by well-known songwriters and recording artists. (CSU)

MUS 177 C Songwriting Workshop **3 Units**

Term hours: 48–54 lecture. This is an intermediate to advanced workshop in popular songwriting. Students will analyze melody, harmony, song form, rhythm, and lyrics as they apply to popular songs. Emphasis will be placed on original compositions, while studying compositions by well-known songwriters and recording artists. May be taken for credit 4 times. (CSU)

MUS 178 C Digital Music Technology **3 Units**

Term hours: 48–54 lecture and 32–36 laboratory. A comprehensive study of how digital technology is used in the music industry today. Designed for students with interest in songwriting, recording, audio production, and/or multimedia. Students will get hands-on experience with MIDI, keyboard synthesizers, sound modules, sequencers, sound editors, notation software, audio file formats (.wav, .mp3, .mid, etc.), and mastering to compact disc. (CSU)

MUS 203AC Theory and Musicianship III **4 Units**

Prerequisite: MUS 103BC.

Term hours: 80–90 lecture and 16–18 laboratory. This course is a continuation of MUS 103BC. Topics include nondominant seventh chords, modulation, secondary dominant and leading-tone chords, binary and ternary form, analysis, sight-singing and ear-training. (UC/CSU)

MUS 203BC Theory and Musicianship IV **4 Units**

Prerequisite: MUS 203AC.

Term hours: 80–90 lecture and 16–18 laboratory. This course is a continuation of MUS 203AC. Topics include borrowed chords, the Neapolitan sixth chord, the augmented sixth chords, ninth, eleventh, and thirteenth chords, sonata-allegro form, chromatic mediant relationships, musical composition, sight-singing and dictation. (UC/CSU)

MUS 212 C Music Promotion and Distribution 3 Units

Term hours: 48–54 lecture. Music entrepreneurs will learn business procedures to form their own company, emphasizing strategies for the sale and promotion of music. The course covers topics such as the music marketing environment, hands-on marketing techniques, online sales and promotion, and the effects of technology in music publishing. (CSU)

MUS 222 C Audio Production for Film I 3 Units

Prerequisite: Mastery

Term hours: 32–36 lecture and 64–72 laboratory. This course explores audio recording, editing and mixing using digital audio workstations. Topics include an introduction to the process of film production, field recording, sound effects and sound design, and synchronizing audio to video. Pass/No Pass/Letter Grade Option. (CSU)

MUS 223 C Audio Production for Film II 3 Units

Term hours: 32–36 lecture and 64–72 laboratory. This course explores audio recording, editing and mixing using digital audio workstations. Topics include ADR, Foley, music editing, and final delivery. (CSU)

MUS 225 C Applied Music 1 Unit

Prerequisite: Audition and concurrent enrollment in a performing ensemble.

Term hours: 24–27 (Private instruction included). For the student seeking individual instruction on piano, voice, guitar, or any standard band or orchestra instrument. A performance at Faculty Juries is required each semester. Vocal and instrumental students should concurrently enroll in a choir or band class, pianists and guitarists should consult with faculty for an appropriate concurrent course. May be taken for credit 4 times. (UC/CSU)

MUS 227 C Intermediate Voice 1 Unit

Prerequisite: MUS 126 C or by audition.

Term hours: 16–18 lecture and 16–18 laboratory. This course continues the study of vocal performance techniques at an intermediate level. As with the beginning level voice class, the intermediate course deals primarily with tone production, breath control, diction, and choices of popular and traditional song literature. May be taken for credit 2 times. (UC/CSU)

MUS 229 C Vocal Repertoire 1 Unit

Prerequisite: MUS 227 C or by audition.

Term hours: 16–18 lecture and 16–18 laboratory. This class provides a workshop environment for the study of vocal repertoire at the intermediate-to-advanced level. Repertoire will be drawn from traditional styles such as art songs, lieder, arias, and oratorios, as well as jazz, musical theater, and contemporary music. Students will focus on the development of their lyric diction and performance skills while being exposed to a wide variety of vocal literature. May be taken for credit 4 times. (CSU)

MUS 231 C Intermediate Guitar 1 Unit

Prerequisite: MUS 130 C, or by audition.

Term hours: 16–18 lecture and 16–18 laboratory. This course continues the study of guitar performance at an intermediate level. Study focuses on the areas of technique, note reading, scales, and chords. A variety of musical styles, from classical to rock, are included in the repertoire. May be taken for credit 2 times. Pass/No Pass/Letter Grade Option. (UC/CSU)

MUS 232 C Classical Guitar 1 Unit

Prerequisite: Audition.

Term hours: 16–18 lecture and 16–18 laboratory. This course involves group instruction in classical guitar technique and interpretation of solo and ensemble literature for the instrument. May be taken for credit 4 times. (UC/CSU)

MUS 235 C Commercial Guitar and Bass 1 Unit

Prerequisite: Audition.

Term hours: 16–18 lecture and 16–18 laboratory. This course emphasizes blues, jazz, and rock techniques for intermediate-to-advanced guitarists and bassists. Topics include scales in all positions, chords, arpeggios, accompaniment styles, reading chord charts and sheet music, and practical theory. Students will obtain vocational “real world” experience to prepare them for careers as a professional guitarist and/or bassist. May be taken for credit 4 times. Pass/No Pass/Letter Grade Option. (UC/CSU)

MUS 236 C Intermediate Piano 1 Unit

Prerequisite: MUS 135 C or by audition.

Term hours: 16–18 lecture and 16–18 laboratory. This is a study of keyboard literature and techniques in a class situation. Emphasis is on individual progress in execution and interpretation. Designed for both music majors and non-majors whose piano skills are beyond Beginning Piano but not yet ready for Applied Music. May be taken for credit 2 times. (UC/CSU)

MUS 238 C Popular Piano 1 Unit

Prerequisite: MUS 135 C or by audition.

Term hours: 16–18 lecture and 16–18 laboratory. This course deals with the study of basic chords to allow keyboard freedom in improvising and song arranging with the use of melody and accompaniment to develop a creative style of playing, essential in popular music. It is designed for non-music majors as well as music majors. May be taken for credit 4 times. (UC/CSU)

MUS 260 C Classical Guitar Ensemble 1 Unit

Prerequisite: Audition.

Term hours: 16–18 lecture and 16–18 laboratory. The Cypress Classical Guitar Ensemble is dedicated to the rehearsal and performance of standard and contemporary duets, trios, quartets, and large ensemble pieces for the classical guitar. The ensemble participates in a department recital each semester. May be taken for credit 4 times. (UC/CSU)

MUS 261 C String Ensemble 1 Unit

Prerequisite: Audition.

Term hours: 16–18 lecture and 16–18 laboratory. The Cypress String Ensemble is dedicated to the rehearsal and performance of standard and contemporary duets, trios, quartets, and large ensemble pieces for the violin, viola, cello and contrabass. The ensemble participates in a department recital each semester. May be taken for credit 4 times. (UC/CSU)

MUS 273 C Concert Band 1 Unit

Prerequisite: Audition.

Term hours: 48–54 hours rehearsal in sectional rehearsals, recording, program production and/or concerts. The student will be involved in the rehearsal and performance of standard wind and band literature. Performances required in the course of the semester may include concerts and tours. May be taken for credit 4 times. (UC/CSU)

MUS 274 C Cypress Symphonic Winds 1 Unit

Prerequisite: Audition.

Term hours: 48–54 hours in sectional rehearsals, recording, program production and/or concerts. The Cypress Symphonic Wind Ensemble is dedicated to the rehearsal and performance of standard and contemporary literature for woodwinds, brass, and percussion. Performances required in the course of the semester may include concerts and tours. May be taken for credit 4 times. (UC/CSU, AA GE)

MUS 276 C Jazz Band 1 Unit*Prerequisite: Audition.*

Term hours: 48–54 hours rehearsal in sectional rehearsals, recording, program production and/or concerts. This course studies the rehearsal and performance of jazz band literature. Sight reading is emphasized as a musical concept. The band performs in concert each semester, and student compositions and arrangements are encouraged. May be taken for credit 4 times. (UC/CSU)

MUS 279 C Madrigal Singers 1 Unit*Prerequisite: Audition.*

Term hours: 48–54 hours rehearsal. The Madrigal Singers is a small ensemble of mixed voices that focuses on the rehearsal and performance of Renaissance madrigal literature. The ensemble performs two major concerts per semester, participates in regional music festivals and performs at a variety of locations throughout the Los Angeles basin. Open to students with previous choral performance experience by audition. May be taken for credit 4 times. (CSU)

MUS 280 C Jazz/Musical Theater Choir 1 Unit*Prerequisite: Audition.*

Term hours: 48–54 hours in sectional rehearsals, recording, program production and/or concerts. This course is a vocal ensemble for beginning to advanced singers that focuses on repertoire from jazz, musical theater and popular styles. The ensemble will perform in concerts and may also participate in music festivals appropriate to this type of vocal group. Open to both music majors and non-majors. May be taken for credit 4 times. (UC/CSU, AA GE)

MUS 281 C Concert Choir 1 Unit*Prerequisite: Audition.*

Term hours: 48–54 hours in sectional rehearsals, recording, program production and/or concerts. The Concert Choir performs an extensive repertoire ranging from Renaissance, Classical, and Baroque selections to contemporary Spirituals, Jazz, and Musical Theater. The choir presents four major concerts each season and participates in regional choral festivals. Open to all singers from the college and neighboring communities. Prospective singers should call for an audition appointment. May be taken for credit 4 times. (UC/CSU)

MUS 282 C Cypress Masterworks Chorale 1 Unit*Prerequisite: Audition.*

Term hours: 48–54 hours in sectional rehearsals, recording, program production and/or concerts. The Masterworks Chorale (80–110 singers) presents four major concerts each year with emphasis on masterworks for choir and orchestra. The Chorale participates in regional music festivals, performs at numerous locations throughout the Los Angeles basin, and tours internationally. Open to students and members of the community with prior singing experience. May be taken for credit 4 times. (UC/CSU, AA GE, CSU GE)

MUS 283 C Cypress Singers 1 Unit*Prerequisite: Audition.*

Term hours: 48–54 hours in sectional rehearsals, recording, program production and/or concerts. The Cypress Singers is a group of 18 sopranos and altos which rehearse and perform a variety of repertoire ranging from Renaissance madrigals to contemporary music. The Singers perform in concerts and festivals each year as scheduling permits. Open to both music majors and non-majors by audition. May be taken for credit 4 times. (UC/CSU)

MUS 285 C Chamber Singers 1 Unit*Prerequisite: Audition.*

Term hours: 48–54 hours in sectional rehearsals, recording, program production and/or concerts. The Chamber Singers is a select group of 24 mixed voices performing a variety of classical repertoire ranging from Renaissance madrigals to contemporary literature. The ensemble performs four major concerts per year, participates in regional music festivals, and performs at numerous locations throughout the Los Angeles basin. Open to both students and members of the community with extensive singing experience. May be taken for credit 4 times. (UC/CSU)

MUS 287 C Vocal Jazz Ensemble 1 Unit*Prerequisite: Audition.*

Term hours: 48–54 hours in sectional rehearsals, recording, program production and/or concerts. This course focuses on the rehearsal and performance of traditional and contemporary vocal jazz repertoire accompanied by a small instrumental ensemble. Some emphasis will be placed upon vocal improvisation in the jazz style. The ensemble will perform in concerts and may also participate in jazz and choral music festivals. Student compositions and arrangements are encouraged. May be taken for credit 4 times. (UC/CSU)

MUS 295 C Music Internship 1 to 4 Units

Term hours: This course is designed to give the student credit for work experience at a related occupational worksite, while being concurrently enrolled in a vocational major. For each unit of credit, a minimum of 75 paid or 60 unpaid worksite internship hours is required. The internship allows students to apply knowledge gained in college courses to an actual work setting, sample career choices and improve job-readiness skills. Supplemental reading and course assignments required. May be taken for credit 4 times. Open Entry/Open Exit. Pass/No Pass/Letter Grade Option. (CSU)

MUS 298 C Advanced Production Techniques .5 to 12 Units*Prerequisite: May be required.**Corequisite: May be required.**Advisory: May be required.*

Term hours: 0–216 lecture and/or 0–936 laboratory depending on units attempted. Various classes may be offered which are designed to meet the interests and needs of students. Fees may be required — Payable at Registration. May be taken for credit 1–4 times. Pass/No Pass or Pass/No Pass/Letter Grade Option or Standard Letter Grade. (UC Credit Limitation/CSU)

MUS 299 C Music — Independent Study 1 to 2 Units*Prerequisite: Approved Independent Study Learning Contract.*

Term hours: 16–36 lecture. This course is designed for students who wish to increase their knowledge and experience in performance or applied areas. Unit credit may range from 1 to 2 units in any given semester. Consult the class schedule to verify credit for a particular term. May be taken for credit 4 times. (UC Credit Limitation/CSU)

Nursing Program

Registered

Division of Health Science

EFFECTIVE FOR STUDENTS

ENTERING FALL, 1994, AND LATER.

Division Dean — John Sciacca

Director of Nursing — Darlene Fishman

Faculty

Shirley Ashburn

Michael Faraci

Darlene Fishman

Sally Frumkin

Carol Harvey

Anna Herzog

Kathleen Kruse

Denise Markus

Sally McNay

Elizabeth Putman

Judy Swytak

Wendy Valencia

Jane Walker

Merreda Williams

Janet Winckler

Counselors

Kelly Carter

Denise Vo

PROGRAM LEARNING OUTCOMES (PLOs)

Nursing

A student who completes the Nursing program will be able to:

- Manage effective communication with the patient/client, family, health care team, and community.
- Formulate and prioritizes nursing diagnoses through assessment/observation of the patient/client's physical condition and behavior, and through interpretation/analysis of information obtained from the patient/client and others, including the health care team.
- Create a plan of care in collaboration with the patient/client which ensures that direct and indirect nursing care services are provided for the patient/client's safety, comfort, hygiene, and protection, and for disease prevention, health promotion, and restorative measures.
- Perform skills essential to implement safe and effective nursing care; explains health treatment, and teaches patient/client and family how to care for their health needs.
- Delegate tasks to subordinates based on the legal scope of their practice and on the preparation and capability needed or the tasks delegated; effectively supervise nursing care given by subordinates.
- Evaluate the expected outcomes of the plan of care through observation of the client's physical condition, behavior, signs and symptoms of illness, reactions to treatment, and through communication with the patient/client and the health care team members; modifies/progresses plan as needed.

- Advocate for the patient/client by initiating action to improve health care and to make informed decisions.
- Evaluate personal strengths and growth needs and incorporate these into a plan for professional development.
- Practice according to ethical and legal professional nursing standards.

Accredited by: (NLNAC)

National League for Nursing Accrediting Commission

3343 Peachtree NE, Suite 500

Atlanta, GA 30326

(404) 975-5000

Fax (404) 975-5020

PHILOSOPHY OF NURSING EDUCATION

The philosophy of the Cypress College Associate in Science Degree Nursing Program recognizes the individual as a whole person who moves toward goals of self-realization and fulfillment. The individual is self-directed and is responsible for his/her own actions as well as the consequences of the actions. The faculty of the Department of Nursing supports this view of the individual in its approach to the teaching of nursing.

TEACHING/LEARNING

The nursing faculty believes that learning is a dynamic process which results in behavioral changes. Learning occurs throughout the life cycle and can aid in maximization of any individual's potentials. The individual student's potentials are developed through use of the nursing process, a professional proactive approach to problem-solving. The curriculum provides opportunities for facilitating learning based on individual styles of learning. Self-motivation and active participation in the classroom and clinical laboratory are necessary components of the learning process for adult learners.

The curriculum is organized from simple to complex concepts which are as identified in each course outline. Multiple methods of instruction are utilized to address the content being studied, to enhance learning, and to provide for individual differences in both teaching and learning styles. The structure and content of each course is designed to support the department's philosophy of nursing education. The student is recognized as an individual who moves toward goals of self-realization and fulfillment.

ROLE OF THE TEACHER AND STUDENT

The role of the teacher is to identify the learning needs of the student and to facilitate the student's optimal level of learning achievement. A systematic approach is utilized to assist the student in assessment of learning needs, development of learning goals, selection and implementation of learning methods and strategies, and evaluation of outcomes. Differences in individual needs, learning styles, ethnicity and cultural background are essential considerations in effective teacher-student relationships.

CURRICULUM MODEL

The nursing curriculum model is based on a conceptual framework which focuses on the individual within his/her family and community. The individual exhibits needs at varying levels within the biopsychosocial/spiritual domains. The purpose of the model is to provide a framework to which the students can relate course content and nurse-patient interaction. The conceptual model encourages the use of varied theories to explain a person's behavior in response to his/her environment. Abraham Maslow's Hierarchy of Needs is emphasized to examine human needs and behavior as the person moves toward the ultimate goal of self-actualization. Learning experiences are planned to incorporate the health needs of individuals in all age and developmental groups at various placements on the health-illness continuum.

NURSING AND THE NURSING PROCESS

The function of nursing is to identify the needs of the client/family and to promote or support the client's/family's optimal level of adaptation on the health-illness continuum. The nurse's role is to assess and diagnose the behavioral responses and intervene on behalf of the client to achieve maximal wellness. The nursing process, based on the application of principles derived from the biological and behavioral sciences, is used as a systematic approach in the planning, implementation, and evaluation of individualized nursing care for a client/family.

NURSING AND PERSONAL RESPONSIBILITY FOR HEALTH PROMOTION PRACTICES

The Cypress College nursing faculty recognizes the value of high-level wellness and supports the concept of the nurse being a positive role model for health practices. The entering student needs to be aware of his/her health-promoting behaviors in the area of general health (i.e., rest and sleep, nutrition, therapeutic recreation). The student should also be aware of and avoid behaviors detrimental to health.

SPECIAL REQUIREMENTS, EQUIPMENT AND EXPENSES INCURRED BY NURSING STUDENTS UPON ENROLLMENT IN THE NURSING PROGRAM

This information is intended to assist those who are planning enrollment in the registered nursing program prepared for educational expenses. In addition to enrollment fees PAYABLE AT REGISTRATION, the nursing student incurs additional expenses. The nursing student should anticipate an expenditure of approximately \$3,500 over the two years of enrollment in nursing program courses.

Clinical practice sites are located throughout Orange and Los Angeles counties. Clinical rotations may be scheduled for both day and evening shifts in order to provide the best learning opportunities. The student will need reliable personal transportation in order to travel to assigned hospitals at least two days a week in each nursing course.

The nature of the learning experiences in the registered nursing program requires that students engage in direct patient care in assigned clinical facilities. All enrolled students are required to meet the same health and safety standards required of nurses in the contracted clinical facilities. For this reason each student enrolled in the nursing program must complete the following requirements at his/her own expense prior to the first day of attendance:

1. **Physical examination with health clearance indicating good physical and mental health status with no limitations to providing direct patient care.**
2. Proof of current immunizations or immunity by titer.
3. Testing for communicable diseases including, but not limited to, the following: Tuberculosis, rubella, rubeola, varicella, hepatitis.
4. Malpractice insurance.
5. Current CPR certification at the Professional Health Provider level.
6. Background checks.

In addition, the student will need to purchase required uniforms, watch with sweep second hand, name badge, stethoscope, and other equipment required for clinical practice.

Information regarding the specific requirements in place at the time of initial enrollment into nursing clinical courses is provided at a mandatory orientation meeting scheduled for applicants selected each semester.

ASSOCIATE IN SCIENCE DEGREE PROGRAM REGISTERED NURSING Program Code: 1S03785

The program educates nursing students for patient/client services in a variety of health care settings. Clinical experience in hospitals and other health care agencies is correlated with classroom instruction. At the satisfactory completion of all courses and the specified general education requirements, the individual will receive an Associate in Science degree and will be eligible to write the Registered Nursing State Licensing Examination. **(If you have been convicted of any offense other than a minor traffic violation, it may prevent your attending clinical rotations where criminal background checks are required. You will be required to declare offenses on your state application to write the licensing exam, which may affect your eligibility to become licensed.)**

The nursing program is approved by California State Board of Registered Nursing and nationally accredited by the NCNAC. For the requirements to complete the Associate in Science Degree, see the Graduation Requirements for the Associate Degree section of this catalog.

MINIMUM STANDARDS FOR APPLICANTS

1. Eligibility for admission to Cypress College.
2. High school graduation, or passing of the General Education Development Test (GED), or the High School Proficiency Test, or a graduate of an accredited college.
3. Good physical and mental health as determined by a medical examination upon admission to the program. In compliance with the *State Board of Registered Nursing Guidelines*, no student with impaired health status (which includes use of legal or illegal drugs, alcohol, or other chemicals) shall be admitted or allowed to remain enrolled in the Nursing Program. Students applying to the Nursing Program with a history of substance abuse, physical impairment, or mental/emotional impairment shall be required to provide proof of active participation in a recognized treatment program at the time of application. Evidence of continuing rehabilitation may be required

if admitted or re-admitted to the Nursing Program. These standards are necessary for the Cypress College Registered Nursing Program to be in compliance with the *Board of Registered Nursing Guidelines* and maintain full accreditation.

4. Total college grade point average (GPA) of 2.0 (“C”) or better.
5. Completion of ENGL 100 C with “C” or better as determined by a counselor from transcript.
6. Completion of Biology 231 C (General Anatomy), Biology 241 C (Human Physiology), (CHEM 101 C strongly recommended), and Biology 220 C (Medical Microbiology) with “C” or better. All must have been completed within five years of application.

APPLICATION PROCEDURES

September 1–10*

Applications must be completed **online** September 1–10. Please see the **Health Science Application link** on the Registered Nursing home page.

Applicants must submit official transcripts (except Cypress and Fullerton Colleges) and signature page **in person** to the Health Science Applications office, Health Science Building, Cypress College 9200 Valley View Street, Cypress, California 90630-5897 by **October 1st**. Please bring photo identification.

The Nursing Program admits students twice each year, fall and spring. Applicants will be notified of status via email.

All applicants who wish to remain on the applicant list must file an updated application every year during the application period in September. Applicants again will be notified of updated status in writing.

Notify the Health Science Application Office in Writing:

1. if you change your name, address or telephone number
2. if you wish to withdraw your name as an applicant

Please Note: F-1 visa students will not be accepted for admission into any program when applications by qualified U.S. citizens exceed space available.

*Contact Health Science Application Office for the specific final days of application, hours and last day to submit transcripts because of holidays or weekends, (714) 484-7270.

REGISTERED NURSING CURRICULUM

Program Code: 1S03785

Nursing courses must be taken in specific sequence. For further information, see a Health Science Counselor. The student must attain a minimum grade of “C” in each required course to continue in the program.

All students will have to meet the pre-requisites of English 100, Anatomy, Physiology, and Microbiology. The nursing program also requires completion of Introduction to Psychology, Introduction to Sociology, and Human Communication.

Per SB 139, section 66055.8 of the Education Code, California Community Colleges that operate a registered nursing program shall waive the general education requirements for the associate of science degree, in Nursing, for any student who has been admitted to the program and who has already earned a baccalaureate or higher degree. Cypress College will only accept degrees granted from a regionally accredited institution of higher education.

Required Courses are listed in required sequence:

Course #	Title	Units
PREREQUISITES		
###BIOL 231 C	General Human Anatomy	4
###BIOL 241 C	General Human Physiology	4
###BIOL 220 C	Medical Microbiology	4
*ENGL 100 C	College Writing	3
		15
SEMESTER I		
NURS 191 C	Pharmacology in Nursing I	1
***PSY 101 C	Introduction to Psychology	3
NURS 192 C	Fundamentals of Nursing	4.5
NURS 193 C	Intro to Medicine-Surgery/Gero Nursing	3.5
		12
SEMESTER II		
NURS 195 C	Pharmacology in Nursing II	1
#SOC 101 C	Introduction to Sociology	3
	Physical Education Requirement	1
NURS 196 C	Medical-Surgical Nursing I	5
NURS 197 C	Maternal/Newborn Nursing	3.5
		13.5
SUMMER SESSION		
	*Art (Category C1) Requirement	3
SEMESTER III		
#COMM 100 C	Human Communication	3
NURS 291 C	Pharmacology in Nursing III	1
NURS 292 C	Medical-Surgical Nursing II	5
NURS 293 C	Mental Health Nursing	3.5
NURS 294 C	Geriatric Nursing	3
		15.5
SEMESTER IV		
NURS 295 C	Pharmacology in Nursing IV	.5
***#MATH 040 C	Intermediate Algebra (or higher)	4
NURS 296 C	Child/Family Nursing	3.5
NURS 297 C	Medical-Surgical Nursing III	5
	*Humanities (Category C2)	3
		16

*A score of 3 or higher on the Advanced Placement (AP) English Lang. and Comp. or English Lit. and Comp. exam meets this requirement upon petition through Admissions and Records. See a counselor for more information.

**A score of 3 or higher on the Advanced Placement (AP) Psychology exam meets this requirement upon petition through Admissions and Records. See a counselor for more information.

***A score of 3 or higher on the Advanced Placement (AP) Math (Calculus AB) or Math (Calculus BC) exam meets this requirement upon petition through Admissions and Records. See a counselor for more information.

#May be taken prior to program for selection purposes, but **must be** completed at least by semester indicated.

##Proficiency Examination available—see Health Science Counselor.

###Must be taken within five years of application.

All nursing courses are challengeable. See Nursing Program Director.

Graduation requirements: Cultural Diversity (beginning Fall 2000 catalog, the nursing program meets the requirement) and Reading Proficiency. See Counselor/Catalog.

TRANSFER OF CREDIT

Transfer credit for nursing courses taken from another accredited institution may be granted provided the applicant meets the Cypress College Department of Nursing entrance requirements and space is available in the program. Contact the Health Science Application Office for written policy and procedure.

Credit will be granted on an individual basis after evaluation by the Department of Nursing. Transfer credit for equivalent general education courses required by the Department of Nursing will be granted if the course has been completed at an accredited college.

Any required course in the biological or Social Sciences listed below, completed over five years previous to the time the student applied to the program, must be repeated or the student may receive credit by challenge examination, or be evaluated on an individual basis.

BIOL 231 C	General Human Anatomy
BIOL 241 C	General Human Physiology
BIOL 220 C	Medical Microbiology

CAREER MOBILITY: LICENSED VOCATIONAL NURSE TO REGISTERED NURSE Program Code: 1S00003

LICENSED PSYCHIATRIC TECHNICIAN TO REGISTERED NURSE Program Code: 1S00004

The nursing program provides an opportunity for Licensed Vocational Nurses and Licensed Psychiatric Technicians to complete the Registered Nursing curriculum. The individual completing the registered nursing program and general education requirements is eligible to take the Registered Nursing State Licensing Examination. As a graduate of the Cypress College Registered Nursing Program, the student will receive an Associate in Science degree.

MINIMUM STANDARDS FOR APPLICANTS

1. Eligibility for admission to Cypress College.
2. High school graduation or passing of the General Education Development (GED) test or the High School Proficiency Test or a graduate of an accredited college.
3. Good physical and mental health as determined by a medical examination upon admission to the program. In compliance with the *State Board of Registered Nursing Guidelines*, no student with impaired health status (which includes use of legal or illegal drugs, alcohol, or other chemicals) shall be admitted or allowed to remain enrolled in the Nursing Program. Students applying to the Nursing Program with a history of substance abuse, physical impairment, or mental/emotional impairment shall be required to provide proof of active participation in a recognized treatment program at the time of application. Evidence of continuing rehabilitation may be required if admitted or re-admitted to the Nursing Program. These standards are necessary for the Cypress College Registered Nursing Program to be in compliance with the Board of Registered Nursing Guidelines, and maintain full accreditation.
4. Verification of completion of a program or its equivalent preparing for a Licensed Vocational Nurse or Psychiatric Technician and 6 months experience at the time of application.
5. Successful completion of the Career Mobility Proficiency Exams. (See Health Science Counselor for specific information on testing criteria and procedures.)

6. Successful completion of the Career Mobility Clinical Skills Validation Performance Exam. (See Health Science Counselor for specific information on testing criteria and procedures.)
7. Total college grade point average (GPA) of 2.0 (“C”) or better.

PREREQUISITES

Completion of the following courses with a grade of “C” or better:

Course #	Title	Units
##BIOL 231 C	General Human Anatomy	4
##BIOL 241 C	General Human Physiology	4
##BIOL 220 C	Medical Microbiology	4
*ENGL 100 C	College Writing	3
+**PSY 101 C	Introduction to Psychology	3
#NURS 090 C	Nursing Transitions	3.5
		21.5

#This course, available in the summer only, includes a clinical rotation. It is required for career mobility students seeking advancement into the Registered Nursing Program. Applicants will be assigned a placement number on the qualified mobility placement list upon successful completion of this course with a grade of “C” or better.

##Must be taken within ten years of application.

+May be in progress at the time of application, but must be completed prior to acceptance in the Nursing Program.

*A score of 3 or higher on the Advanced Placement (AP) English Lang. and Comp. or English Lit. and Comp. exam meets this requirement upon petition through Admissions and Records. See a counselor for more information.

**A score of 3 or higher on the Advanced Placement (AP) Psychology exam meets this requirement upon petition through Admissions and Records. See a counselor for more information.

APPLICATION DEADLINES

FALL OR SPRING CLASSES

Applications are accepted after successful completion of career mobility proficiencies and skills validation testing. A counseling appointment is mandatory to review program and application procedure.

APPLICATION REQUIREMENTS

1. Must have completed all prerequisites.
2. Possess a current California LVN or PT license.
3. Must have completed application
4. Satisfactory completion of NURS 090 C, with a grade of “C” or better.

CAREER MOBILITY: LVN/PT TO REGISTERED NURSING CURRICULUM

General Education requirements — the following courses must be completed prior to expected date of graduation with a grade of “C” or better.

Course #	Title	Units
SOC 101 C	Introduction to Sociology	3
COMM 100 C	Human Communication	3
MATH 040 C	Intermediate Algebra (or higher)	4
	Art (C1 course)	3
	Humanities (C2 Course)	3
	Physical Education Requirement	1
		<hr/> 17
	Reading Proficiency	

NOTE: All Cypress College graduates must meet the following two requirements: Cultural Diversity (beginning with the Fall 2000 catalog, the nursing program meets the requirement) and Reading Proficiency. See counselor/catalog.

Nineteen and one half units may be awarded for holders of a valid California Vocational Nursing license. Credits are posted to transcripts upon completion of all other graduation requirements. Students must provide a copy of their current California license with their application to the Director of Nursing to be eligible for this credit.

Fourteen and one half units may be awarded for holders of a valid California Psychiatric Technician license. Credits are posted to transcripts upon completion of all other graduation requirements. Students must provide a copy of their current California license with their application to be eligible for this credit.

LICENSED VOCATIONAL NURSE TO REGISTERED NURSE Program Code: 1S00003

Required courses are listed in sequence:

Course #	Title	Units
SEMESTER I		
NURS 292 C	Medical-Surgical Nursing II	5
NURS 293 C	Mental Health Nursing	3.5
NURS 294 C	Geriatric Nursing	3
SEMESTER II		
NURS 295 C	Pharmacology in Nursing IV	.5
NURS 296 C	Child/Family Nursing	3.5
NURS 297 C	Medical-Surgical Nursing III	5
	Total Units Required	<hr/> 20.5

PSYCHIATRIC TECHNICIAN TO REGISTERED NURSE Program Code: 1S00004

Course #	Title	Units
SEMESTER I		
NURS 196 C	Medical-Surgical Nursing I	5
NURS 197 C	Maternal/Newborn Nursing	3.5
SEMESTER II		
NURS 292 C	Medical-Surgical Nursing II	5
NURS 294 C	Geriatric Nursing	3
SEMESTER III		
NURS 295 C	Pharmacology in Nursing IV	.5
NURS 296 C	Child/Family Nursing	3.5
NURS 297 C	Medical-Surgical Nursing III	5
	Total Units Required	<hr/> 25.5

CAREER MOBILITY: LICENSED VOCATIONAL NURSE TO NON-DEGREE REGISTERED NURSE

A Licensed Vocational Nurse may apply for admission to the Registered Nursing Program to meet the requirements for licensure of the State Board of Registered Nursing in California. Thirty-Unit Option applicants shall have equal access to open space in the required nursing courses.

MINIMUM STANDARDS FOR APPLICANTS

1. Applicants must meet Cypress College entrance requirements.
2. Verification of completion of a program or its equivalent, preparing for a Licensed Vocational Nurse.
3. Satisfactory completion of BIOL 210 C, with Lab, 5 Units (or equivalent) with a grade of “C” or better.
4. Satisfactory completion of (or concurrent enrollment in) BIOL 220 C, (or equivalent) with a grade of “C” or better.

APPLICATION DEADLINES

Applications are accepted after successful completion of career mobility proficiency and skills validation. A counseling appointment is **mandatory** to review program and application procedure.

SELECTION PROCEDURE

Applications normally exceed capacity. Applicants should obtain specific information and counseling information sheets from the Health Science Counseling Office. It is the applicant’s responsibility to verify that documents, transcripts and records are on file.

30-UNIT NON-DEGREE OPTION CAREER MOBILITY: LICENSED VOCATIONAL NURSE TO NON-DEGREE REGISTERED NURSE

A Licensed Vocational Nurse may apply for admission to the Nursing Program to meet the requirements for licensure of the State Board of Registered Nursing in California. Thirty-Unit Option applicants shall have equal access to open space in the required nursing courses.

CURRICULUM

Courses **MUST** be taken in this specified sequence:

Natural Science Requirement — 9 Units

Course #	Title	Units
BIOL 210 C	Anatomy and Physiology	5
BIOL 220 C	Medical Microbiology	4

Nursing Requirement — 20 Units

NURS 090 C	Nursing Transitions	3.5
NURS 292 C	Medical-Surgical Nursing II	5
NURS 293 C	Mental Health Nursing	3.5
NURS 294 C	Geriatric Nursing	3
NURS 297 C	Medical-Surgical Nursing III	5
	Total Units Required	<hr/> 29

ASSOCIATE IN SCIENCE DEGREE FOR REGISTERED NURSES FROM A DIPLOMA SCHOOL OF NURSING

This program is designed to enable a Registered Nurse from a diploma school of nursing to earn an Associate in Science Degree. Diploma Nursing School graduates with a current California license will receive 40 units of credit towards an Associate in Science Degree upon completion of general education and residency requirements at Cypress College. For the requirements to complete the Associate in Science Degree, see the Graduation Requirements for the Associate Degree section of this catalog. A petition is required for students requesting a waiver if 50% of their coursework in the major was not completed at Cypress College. See your Health Science Counselor.

Nursing Four Year

TRANSFER PROGRAM

Students should consult a counselor or www.assist.org for lower division major requirements for most California public universities. (See the Standard Definitions section of the catalog for a description of ASSIST.) Students transferring to an independent college/university should consult the catalog of the individual school and a counselor for lower division major requirements.

Nursing (NURS)

NURS 090 C Nursing Transitions 3.5 Units

Prerequisite: Licensed Vocational Nurse (LVN), or Licensed Psychiatric Technician (LPT) with no less than six months documented work experience in their licensed capacity, and successful completion of career mobility proficiency exams and skills validation test.

Course hours: 32–36 lecture and 72–81 laboratory. This course is designated for the experienced (no less than six months documented work experience in their licensed capacity) LVN/LPT who is preparing to enter the Registered Nursing career ladder program. The course will enhance theoretical and technical nursing skills in areas such as communication, ethics, fluid and electrolytes, and pharmacology. Students will develop in-depth skill in utilization of the nursing process. Major emphasis is placed on assessment of patient's biopsychosocial needs. The course emphasizes specific knowledge and skills not included in LVN/LPT curricula. \$19.00 Laboratory Fee — Payable at Registration.

NURS 091 C Strategies — Success in Nursing .5 Units

Term hours: 8–9 lecture. This course is designed as a preparatory seminar for nursing students. The course will begin to develop the skills needed to succeed in a health care curriculum where students must be able to assimilate knowledge and apply it in a clinical practice setting. The course will provide students with behavioral and problem solving tools to develop personal and professional strategies for success in the health care field. Non-Degree Credit. Pass/No Pass/Letter Grade Option.

NURS 099 C Nursing Independent Study .5 to 2 Units

Prerequisite: Approved Independent Study Learning Contract.

Term hours: 8–36 depending on units attempted. This course is designed for capable students enrolled in the Registered Nursing program or options of the program who wish to increase their knowledge and experience in applied areas. Students will participate in independent study on assigned areas under staff supervision. Variable Unit Class. May be taken for credit 4 times. Pass/No Pass/Letter Grade Option.

NURS 101 C Critical Thinking in Nursing .5 to 2 Units

Prerequisite: Acceptance in the Nursing Program or Registered Nurse.

Term hours: 8–36 lecture depending on units attempted. The focus of this course is one of assisting students in the development of critical thinking skills and the application of those skills to the nursing process. The role of analysis, synthesis and theory in the nursing process will be addressed. Case studies and nursing situations will be presented and the student will be guided through analysis of data in order to develop appropriate nursing diagnosis, patient goals/outcomes and nursing interventions. This course is an elective for students who desire additional assistance in developing nursing process skills. Computer simulations and computer testing will be used within this course. \$3.00 Material Fee — Payable at Registration. May be taken for credit 4 times. Pass/No Pass/Letter Grade Option. (CSU)

NURS 103 C Basic Health Assessment .5 Units

Prerequisite: NURS 192 C; Licensed Psychiatric Technician; Licensed Vocational Nurse; Registered Nurse.

Term hours: 8–9 lecture. This elective course provides specialized nursing knowledge in assessing basic health status in the non-pregnant adult. Nursing process is the framework that includes techniques for both history and physical assessment. Nursing implications of selected common health problems are emphasized. Pass/No Pass/Letter Grade Option. (CSU)

NURS 104 C Introduction to ECG Interpretation .5 Units

Prerequisite: NURS 191 C, NURS 193 C; Licensed Vocational Nurse; Registered Nurse or permission of instructor.

Term hours: 8–9 lecture. This elective course provides specialized nursing knowledge in assessing and caring for patients experiencing selected common cardiac dysrhythmias. These include sinus, atrial, AV heart blocks, junctional, and ventricular dysrhythmias. Initial patient monitoring, lead placement, techniques and equipment utilized to measure and identify cardiac arrhythmias are addressed in introductory terms. Basic therapies based on current ACLS standards and nursing implications for these dysrhythmias are discussed. Pass/No Pass/Letter Grade Option. (CSU)

NURS 105 C Basic Cardiopulmonary Nursing .5 Units

Prerequisite: NURS 292 C; Registered Nurse; or permission of instructor.

Term hours: 8–9 lecture. This elective course provides specialized nursing knowledge in common cardiopulmonary health problems and their nursing implications. Nursing process serves as the framework for this exploration. Duplicate credit not granted for NURS 105HC. Pass/No Pass/Letter Grade Option. (CSU)

NURS 105HC Honors Cardiopulmonary Nursing .5 Units

Prerequisite: NURS 292 C, Registered Nurse; or permission of instructor.

Term hours: 8–9 lecture. This elective course is enhanced for honors students. Students shall develop increased knowledge of cardio-pulmonary health problems as they analyze expanded concepts of the nursing process and health care delivery. Duplicate credit not granted for NURS 105 C. (CSU)

NURS 107 C Pain Management for Nurses 1 Unit

Prerequisite: NURS 192 C with a minimum grade of "C."

Term hours: 16–18 lecture. This course introduces the student to pain assessment and management strategies for use in daily clinical practice, based on the California Board of Registered Nursing's Pain Management Policy. Physiologic, psychologic, sociologic, and cultural aspects of pain are examined within the context of the nursing process. The student will learn to effectively prevent and control patient pain and improve patient outcomes by pharmacologic and non-pharmacologic means. Ethical issues and barriers to effective pain management are considered. Pass/No Pass/Letter Grade Option. (CSU)

NURS 108 C Orthopaedic Patient Care .5 Units*Advisory: NURS 192 C.*

Term hours: 8–9 lecture. This course is an overview of the general concepts of orthopaedic nursing including assessment, orthopaedic injuries, patient complications, and orthopaedic patient care. Designed to give the participant an introduction to the specialty of orthopaedic nursing, this course includes study of the care of patients experiencing orthopaedic trauma, traction or cast treatment, total joint arthroplasty, spinal surgery, amputation, as well as orthopaedic complications. The content of the course is based on orthopaedic nursing practice standards and patient teaching implications as developed by the National Association of Orthopaedic Nurses. May be taken for credit 2 times. Pass/No Pass/Letter Grade Option. (CSU)

NURS 109 C RN Practicum and Career Development 1 to 4 Units*Prerequisite: NURS 196 C.**Corequisite: Concurrent enrollment in Registered Nursing Program.*

Term hours: 8–9 lecture and 24–189 laboratory. This course focuses upon exploring work related issues in an acute hospital setting. The course will provide opportunities enabling students to apply previously learned theory and clinical skills in which the student has demonstrated competence. The course may provide exposure to additional areas of care with the agreement of the faculty and instructor and previous enrollment in nursing practicum. Requires a minimum eight hours employment per week in an approved acute care agency. As required by the Board of Registered Nursing regulations, no new skills will be taught. Variable Unit Class. May be taken for credit 4 times. Pass/No Pass/Letter Grade Option. (CSU)

NURS 190 C Introduction to Nursing Concepts 2 Units

Term hours: 32–36 lecture. This course introduces the health science student to the theoretical basis of nursing and health care, including psychosocial concepts inherent to development of skills needed for patient care and the nurse-patient relationship. Professional nursing roles and interaction skills are applied to the health care setting. The effects of developmental patterns on individual health care needs are introduced. Major social and cultural issues in relation to health care are discussed. Teaching/learning strategies unique to health care, nursing, and clinical instruction are explored. \$20.00 Material Fee — Payable at Registration. (CSU)

NURS 191 C Pharmacology in Nursing I 1 Unit*Prerequisite: Acceptance in the Nursing Program, LVN or PT.*

Term hours: 16–18 lecture. This course introduces the principles of medication administration, laws governing drugs, and the role of the nurse in administering medications in the health care setting. Drug action, preparations, and basic pharmacologic terminology are included. Criteria for monitoring drug interactions, with emphasis on the older adult, is presented. The general effects of pharmacological agents on the autonomic and central nervous systems are introduced. The therapeutic effects, interactions, adverse effects, and the identification of nursing responsibilities in administering anti-inflammatory drugs are emphasized. Mathematical concepts related to metric, apothecary, and household systems of measurement, and temperature and systems conversions are taught. Ratio and proportion and evaluation of intake and output measurements are introduced. (CSU)

NURS 192 C Fundamentals of Nursing 4.5 Units*Prerequisite: Acceptance in the Nursing Program.*

Term hours: 40–45 lecture and 96–108 laboratory. This course is an introduction to the nursing process, applying Maslow's hierarchy to nursing technology and the scientific mind. The course is designed to provide the student with fundamental provider of care roles and critical thinking skills in order to develop and deliver a basic plan of care. The nursing management portion of the course is designed to socialize the beginning nursing student to the professional role of nursing. Models of health care delivery systems and organizations will be explored. Nursing issues regarding patient rights, ethical and legal standards, and the use of professional communication will be applied to nursing theory and practice. \$20.00 Material Fee — Payable at Registration. (CSU)

NURS 193 C Introduction to Medicine-Surgery/Gero Nursing 3.5 Units*Prerequisite: NURS 192 C.*

Term hours: 24–27 lecture and 96–108 laboratory. This course provides specialized knowledge to plan and deliver nursing care, based on the nursing process, to the older adult. Included in the healthy aging concept is a compilation of age-associated issues and preventive health considerations for the senior. This course is designed to socialize the beginning nursing student to the professional role of nursing as it relates to the care of the older adult. Models of health care delivery systems and organizations for the senior will be explored. Nursing issues regarding patient rights, ethical and legal standards, and the use of professional therapeutic communication will be applied to nursing theory and practice. (CSU)

NURS 195 C Pharmacology in Nursing II 1 Unit*Prerequisite: Acceptance in the Nursing Program, LVN, PT or completion of NURS 191 C and NURS 193 C.*

Term hours: 16–18 lecture. This pharmacology courses correlates with the content in NURS 196 C and NURS 197 C. Theoretical concepts for the assessment of patient responses to medication and the safe administration of medications in health care settings will be emphasized. By the end of this course, students will demonstrate competency on a written exam in advanced calculations using ratio and proportion methods to calculate dosages for parenteral medications and IV flow rates for mainlines and piggyback medications. The therapeutic effects, interactions, adverse effects, and the identification of nursing implications of drug administration will be presented for selected drug categories (cardiac, allergy medications, antibiotics, gastrointestinal/antacids, coagulation/vascular medications, vitamins, estrogens, perinatal and renal medications, anticonvulsants, anesthetics and insulin and hypoglycemics). (CSU)

NURS 196 C Medical-Surgical Nursing I 5 Units*Prerequisite: NURS 191 C, and NURS 193 C.*

Term hours: 36–41 lecture and 132–148 laboratory. This course prepares the student to apply the nursing process to develop nursing care strategies in the care of medical-surgical patients. There will be an emphasis on nursing interventions that require psychosocial assessment and therapeutic communication. The course introduces the student to the basic concepts of patient teaching and the role of research application. The professional nursing management portion of the course is designed to build on previous knowledge and skills. Emphasis will be on enhancing styles of effective communication, psychosocial assessment and intervention, and patient teaching skills. The student will learn to apply Maslow's theory in prioritizing patient needs in multiple patient situations. The student will have the opportunity to learn and practice accountability and responsibility for professional actions as a member of the health care team. (CSU)

NURS 197 C Maternal/Newborn Nursing 3.5 Units*Prerequisite: NURS 196 C.*

Term hours: 28–32 lecture and 84–94 laboratory. This course assists the student in applying previously learned concepts of the nursing process to women's health and to the specialized population of the pregnant woman, newborn, and family. The professional management and leadership of this course will focus on the understanding of legal responsibilities, styles of leadership, and beginning research utilization. Emphasis will be placed on collegial communications which will enhance the student's understanding of the need for accountability and responsibility as a professional member of the health care team. Based on previous learning, the student will be expected to identify and prioritize patient needs for a group of assigned patients. (CSU)

NURS 209 C Advanced RN Practicum and Career Development 1 to 4 Units*Prerequisite: Successful completion of NURS 292 C.**Corequisite: Concurrent enrollment in the Registered Nursing Program or permission of the Director of Nursing.*

Term hours: 8–9 lecture and 24–27 laboratory. This course focuses upon exploring work related issues in an acute hospital setting. The course will provide opportunities enabling students to apply previously learned theory and clinical skills in which the student has demonstrated competence. The course may provide exposure to acute areas of complex care with the agreement of the facility and instructor and previous enrollment in nursing practicum. Requires a minimum eight hours employment per week in an approved acute care agency. As required by the Board of Registered Nursing regulations, no new skills will be taught. Variable Unit Class. May be taken for credit 4 times. Pass/No Pass/Letter Grade Option. (CSU)

NURS 291 C Pharmacology in Nursing III 1 Unit*Prerequisite: Acceptance in the Nursing Program, LVN, PT or completion of NURS 195 C, NURS 197 C.*

Term hours: 16–18 lecture. This course correlates with the content in NURS 292 C, NURS 293 C, and NURS 294 C. Theoretical concepts for the safe assessment and administration of medications in the health care setting are emphasized. The role of the nurse in evaluating patient response to drugs will be emphasized. The therapeutic effects, interactions, adverse effects, and the identification of nursing implications of drug administration will be presented for selected drug categories (endocrine/hormonal, antineoplastic/antimetabolites, anticonvulsants, antipsychotic, antidepressants, antiparkinson, and anticholinergics). Assessment and evaluation of the nutritional and fluid and electrolyte needs of the adult and geriatric patient will be presented. Replacement therapies, and IV calculations will be emphasized. (CSU)

NURS 292 C Medical-Surgical Nursing II 5 Units*Prerequisite: NURS 195 C and NURS 197 C, and acceptance in the Nursing Program.*

Term hours: 36–41 lecture and 132–148 laboratory. This course prepares the student to apply the nursing process to individuals with more complex nursing care, developmental, and sociological needs. Prioritizing nursing care for multiple patients will be emphasized. Health education needs of patients and barriers to learning will be explored. Students will learn to recognize the need for current application of research utilization to improve nursing care. The professional role of the nurse in assisting clients to locate and utilize appropriate community resources will be emphasized. Managerial skills will be fostered in the area of team management, quality assessment, and change agent strategies. Personal professional development issues will cover continuing education, value systems, self-analysis, and health care team collaborations. (CSU)

NURS 293 C Mental Health Nursing 3.5 Units*Prerequisite: NURS 291 C and NURS 292 C.*

Term hours: 28–32 lecture and 84–95 laboratory. This course presents historical, cultural, and contemporary research concepts as related to the mental health-illness continuum. Through use of the nursing process and communication, individual emotional needs are assessed and nursing interventions are theoretically designed to promote more effective resolution of these needs. Emphasis is placed on interpersonal process through self-awareness, use of self as a therapeutic agent, and use of community resources. The professional role of the nurse is expanded in the areas ethical, legal, and patient advocacy issues of the mentally ill. (CSU)

NURS 294 C Geriatric Nursing 3 Units*Prerequisite: NURS 292 C.*

Term hours: 24–27 lecture and 72–81 laboratory. This course builds on previous medical-surgical knowledge and skills in applying the nursing process in the older adult with complex multiple system problems. Emphasis will be on lifestyle and physical changes, the process of initiating health referrals, and the outcome criteria for evaluating the client's response to teaching and learning. The student will also explore interventions to increase the client's capacity in relation to activities of daily living. This course emphasizes the professional role of the nurse in assisting clients to locate and utilize appropriate community resources. Managerial skills will be fostered in the area of team management, quality assessment, and change agent strategies. Personal professional developmental issues will cover continuing education, value systems, self-analysis, and health care team collaboration. (CSU)

NURS 295 C Pharmacology in Nursing IV .5 Units*Prerequisite: Acceptance in the Nursing Program, LVN, PT or completion of NURS 291 C, NURS 292 C, NURS 293 C and NURS 294 C.*

Term hours: 8–9 lecture. This course correlates with the content in NURS 296 C and NURS 297 C. Theoretical concepts for the safe assessment and administration of medications in the health care setting are emphasized. The role of the nurse in evaluating patient response to drugs will be emphasized. The therapeutic effects, interactions, adverse effects, and the identification of nursing implications of drug administration in pediatric and acute medical-surgical conditions will be presented. Dosage calculations for pediatric clients, physiological differences in the adult versus pediatric clients, and fluid resuscitations for burn clients will be presented. Pass/No Pass/Letter Grade Option. (CSU)

NURS 296 C Child/Family Nursing 3.5 Units*Prerequisite: NURS 291 C, NURS 292 C, NURS 293 C and NURS 294 C.*

Term hours: 28–32 lecture and 84–95 laboratory. This course assists the student in applying previously learned nursing concepts and skills to the pediatric patient. The student will apply growth and development concepts to the care of multiple patients, utilizing appropriate teaching strategies for children and families in preparation for home care. Accountability, outcome evaluation, professional development, health care team dynamics, ethical issues, and professional trends will be examined. Participation in facility in-service projects and use of current literature is expected. (CSU)

NURS 297 C Medical-Surgical Nursing III 5 Units*Prerequisite: NURS 291 C, and NURS 296 C.*

Term hours: 36–41 lecture and 132–149 laboratory. This course provides advanced theory necessary to administer comprehensive nursing care to adults with acute unstable medical-surgical disorders. The professional nursing management component will examine accountability, outcome evaluation, professional development, health care team dynamics, ethical issues, and professional trends. The skills and knowledge transfer component will provide the student with multiple learning tools for applying theory to promote synthesis and competence necessary for entry into practice. \$25.00 Material Fee — Payable at Registration. (CSU)

Office Administration

**SEE — COMPUTER INFORMATION SYSTEMS FOR
COMPUTER AND OFFICE APPLICATIONS DEGREE
AND CERTIFICATE**

Optometry

OPTOMETRY TRANSFER PROGRAM

Professional programs such as dentistry, medicine, pharmacy, optometry, physician assistant, physical therapy and veterinary medicine are most often graduate programs that require a bachelor degree or significant preparation prior to entering the program. The appropriate preparation varies according to the school and specific program. Students are advised to meet with a counselor to discuss options for their bachelor degree and the lower division requirements for the program and school of their choice.

Pharmacy

PHARMACY TRANSFER PROGRAM

Professional programs such as dentistry, medicine, pharmacy, optometry, physician assistant, physical therapy and veterinary medicine are most often graduate programs that require a bachelor degree or significant preparation prior to entering the program. The appropriate preparation varies according to the school and specific program. Students are advised to meet with a counselor to discuss options for their bachelor degree and the lower division requirements for the program and school of their choice.

Philosophy and Religious Studies

Division of Social Sciences

Division Dean — Nina DeMarkey

Faculty

Robert Cavin

Willis Heusser

Counselors

Velia Lawson

Therese Mosqueda-Ponce

Daniel Pelletier

PROGRAM LEARNING OUTCOMES (PLOs)

The courses taught by this department contribute to the General Education and Basic Skills Program Learning Outcomes. Please refer to General Education and Basic Skills Program Learning Outcomes.

ASSOCIATE IN ARTS DEGREE

PHILOSOPHY

Program Code: 1A6881

The Associate in Arts Degree in Philosophy is designed to develop the reasoning skills needed to understand and evaluate theories about society, persons, reality, knowledge, truth, values, etc. The purpose of which is to uncover the assumptions underlying our understanding of the world and to subject those assumptions to careful scrutiny using the tools of logic. Upon successful completion, students will understand the major concepts and issues that have shaped philosophical traditions and be able to make decisions based on rigorous, logical standards. Skills in thinking and problem solving, research, writing, criticism, and analysis are emphasized. This will include the ability to critically analyze the logical structure of arguments in contemporary social and moral issues and to assess the influential positions on theories of truth and the nature of reality. The precision of thought and expression that philosophy requires makes excellent preparation for a variety of careers. Those who do well in philosophy can expect to think more clearly and logically and to approach problems and issues more systematically. Graduate study is important in Philosophy. Those holding a Master's or Doctoral Degree may find employment in education, law, journalism, health, business, theology, public service and other disciplines where analytical skills are required. A limited number of students who earn graduate degrees in philosophy go on to become college philosophy professors. Those without a graduate degree will find limited career opportunities in direct areas of Philosophy. Courses that fulfill major requirements for an associate degree at Cypress College might not be the same as those required for completing the major at a transfer institution offering a baccalaureate degree.

The Associate in Arts Degree in Philosophy will provide students with an introduction to the field including its analytic foundations and applied areas. The degree curriculum and major provide a sound foundation for transfer students intending further upper-division study as preparation for the baccalaureate degree.

To earn an Associate Degree students must complete: (1) all major course requirements with a minimum grade of "C"; (2) California State University General Education Breadth requirements (CSU GE Breadth) or IGETC general education plan; (3) any elective courses to complete a minimum of 60 units; (4) complete all graduation requirements; and, (5) have an overall GPA of 2.0. At least 50% of all major course work must be completed at Cypress College. Students pursuing more than one specified departmental major may double count a maximum of 7 units to fulfill major requirements.

Courses that fulfill major requirements for an Associate Degree at Cypress College might not be the same as those required for completing the major at a transfer institution offering a Baccalaureate Degree. For information on specific university requirements, please consult with your counselor, or visit the Transfer Center.

Required courses are listed in suggested sequence:

Course #	Title	Units
Six (6) to Nine (9) units from the following Philosophy Required Content Courses:		
PHIL 100 C	Introduction to Philosophy	3
	or	
PHIL 100HC	Honors Intro to Philosophy	(3)
PHIL 160 C	Introduction to Ethics	3
PHIL 201 C	History of Philosophy: Ancient and Medieval	3
PHIL 202 C	History of Philosophy: Modern and Contemporary	3

Three (3) to Six (6) units from the following Philosophy Required Method Courses:

PHIL 170 C	Logic and Critical Thinking	3
PHIL 172 C	Critical Thinking and Writing	3
PHIL 175 C	Symbolic Logic	3

Three (3) units from the following Philosophy Elective Courses:

PHIL 101 C	Intro to Religious Studies	3
PHIL 110 C	Religions of the East	3
PHIL 120 C	Religions of the West	3
PHIL 240 C	Jesus and His Interpreters	3
PHIL 230 C	Philosophy of Religion	3

Three (3) units from the following Elective Courses:

ANTH 102 C	Cultural Anthropology	3
ART 100 C	Introduction to Art	3
ENGL/INDS 110/100 C	Humanities: Ancient and Medieval	3
ENGL/INDS 111/101 C	Humanities: Renaissance–Present	3
MATH 030 C	Plane Geometry	3
MUS 116 C	Music Appreciation	3
PHYS 130 C	Principles of Physics	3
POSC 120 C	Political Theory	3
*POSC 215 C	Comparative Politics	3
**PSY 101 C	Introduction to Psychology	3
	or	
**PSY 101HC	Honors Introduction to Psychology	(3)
PSY/SOC 120 C	Human Sexuality	3
PSY/SOC 161 C	Probability and Stats — Social Sciences	4
PSY 221 C	The Brain and Behavior	3
SOC 101 C	Introduction to Sociology	3
	or	
SOC 101HC	Honors Intro to Sociology	(3)
THEA 100 C	Introduction to the Theater	3

Total Units Required **18**

*A score of 3 or higher on the Advanced Placement (AP) Government and Politics (Comparative) exam meets this requirement upon petition through Admissions and Records. See a counselor for more information.

**A score of 3 or higher on the Advanced Placement (AP) Psychology exam meets this requirement upon petition through Admissions and Records. See a counselor for more information.

**PHILOSOPHY AND RELIGIOUS STUDIES
TRANSFER PROGRAM**

Students should consult a counselor or www.assist.org for lower division major requirements for most California public universities. (See the Standard Definitions section of the catalog for a description of ASSIST.) Students transferring to an independent college/university should consult the catalog of the individual school and a counselor for lower division major requirements.

Philosophy and Religious Studies (PHIL)

PHIL 100 C Introduction to Philosophy **3 Units**

Term hours: 48–54 lecture. This course introduces the student to a variety of philosophical issues in metaphysics, theory of knowledge, and ethics, as well as the methodology used by philosophers to address those issues. The origins of Western philosophy as well as its impact on Western civilization will be emphasized. The course systematically explores and evaluates the concepts of reality, value, knowledge, reason, truth, language, definition, beauty, justice, human nature, personal identity, religion, meaning, and freedom. Analysis and synthesis will be stressed for these and other topics of interest to students and/or instructors. Duplicate credit not granted for PHIL 100HC. (UC Credit Limitation/CSU, AA GE, CSU GE, IGETC)

PHIL 100HC Honors Introduction to Philosophy **3 Units**

Term hours: 48–54 lecture. This course is enhanced for honors students. It introduces the student to a variety of philosophical issues in metaphysics, theory of knowledge, and ethics, as well as the methodology used by philosophers to address those issues. The origins of Western philosophy as well as its impact on Western civilization will be emphasized. The course systematically explores and evaluates the concepts of reality, value, knowledge, reason, religion, meaning, and freedom. Analysis and synthesis will be stressed for these and other topics of interest to students and/or the instructor. Duplicate credit not granted for PHIL 100 C. (UC Credit Limitation/CSU, AA GE, CSU GE, IGETC)

PHIL 101 C Introduction to Religious Studies **3 Units**

Term hours: 48–54 lecture. This course is an introductory study of religion with emphasis on the origins and functions of religion, religious experience, and religious and theological modes of expression. Course content will be drawn from Eastern and Western traditions, ancient, medieval and modern times. (UC/CSU, AA GE, CSU GE, IGETC)

PHIL 110 C Religions of the East **3 Units**

Term hours: 48–54 lecture. This course systematically introduces and analyzes the intellectual and religious histories of India, China, and Japan. Primary focus will be on the ways in which Eastern traditions such as Hinduism, Buddhism, Confucianism, Taoism, and Zen conceive of the cosmos, meaningful human existence and life's ultimate goals. Jainism, Sikhism, and Shinto may also be covered. While the main emphasis will be on basic teachings, this course will also investigate religious practices, cultural settings, social impact, and the historical contexts in which these religions arose. Rituals and religious literature may be used to compare and contrast Asian and Occidental belief systems. A field trip may be required by the instructor. (UC/CSU, AA GE, CSU GE, IGETC)

PHIL 120 C Religions of the West **3 Units**

Term hours: 48–54 lecture. This course is an introduction to Zoroastrianism, Judaism, Christianity, and Islam, as well as the religions of ancient Mesopotamia, Canaan, and Egypt. The history, beliefs, rituals, literature, and art of each religion will be examined with a goal to discovering its conception of God, man, the cosmos, meaningful human existence, and life's ultimate goals. Skills in objective, scholarly analysis of the scripture of each religion will be developed. Religious trends in the Nineteenth and Twentieth Centuries and contemporary secular and religious humanism will be discussed. A field trip may be required by the instructor. (UC/CSU, AA GE, CSU GE, IGETC)

PHIL 135 C Social and Political Philosophy **3 Units**

Advisory: Eligibility for ENGL 100 C.

Term hours: 48–54 lecture. This course is an introduction to social and political thought, especially the central concepts (e.g. democracy, justice, rights, liberty, political authority, political morality, etc.) and issues that arise in classic and contemporary readings. The course involves an examination of the relationship between morality, politics and social justice, from a multi-cultural perspective. Topics include: the sources of legitimate political authority, the meaning of democracy, obligations of citizenship, the nature of the state, the justifications for universal human rights, the foundations of a just society, and how political culture is related to social and political institutions. (UC/CSU, CSU GE, IGETC)

PHIL 160 C Introduction to Ethics **3 Units**

Advisory: Eligibility for ENGL 100 C.

Term hours: 48–54 lecture. This course is an introduction to metaethics, normative ethics, and applied ethics. Fundamental ethical concepts, theories, and arguments in classical, medieval, modern, and contemporary ethical thought are presented, analyzed, and critically evaluated. (UC/CSU, AA GE, CSU GE, IGETC)

PHIL 170 C Logic and Critical Thinking 3 Units*Advisory: Eligibility for ENGL 100 C.*

Term hours: 48–54 lecture. This course focuses on elements of clear, straight, orderly and valid thought, including deductive and inductive reasoning and the accurate use of language. This course explores practical applications of logic. (UC/CSU, AA GE, CSU GE)

PHIL 172 C Critical Thinking/Writing 3 Units*Prerequisite: ENGL 100 C with a grade of "C" or better.*

Term hours: 48–54 lecture. This course is an introduction to the techniques of argument analysis, evaluation, and construction as applied to essay writing. The course includes such topics as standard form and argument patterns; deduction, validity, and soundness; truth-functional arguments, truth-tables, and natural deduction; quantificational arguments; categorical syllogisms and Venn Diagrams; truth; induction, strength, and cogency; sampling arguments, causal arguments, statistical syllogisms, analogical arguments, and explanatory arguments; the probability calculus; formal and informal fallacies; and definition, language, and meaning; thesis statements, the writing of coherent, well-developed essays, and grammar, punctuation, and orthography. (UC/CSU, AA GE, CSU GE, IGETC)

PHIL 175 C Symbolic Logic 3 Units

Term hours: 48–54 lecture. This is a course in elementary, truth-functional, propositional logic and first-order quantificational predicate logic, up through identity and definite descriptions. The course covers the techniques for the translation of English statements and arguments into formal logical languages and the methods for determining whether these arguments are valid. (UC/CSU, CSU GE)

PHIL 201 C History of Philosophy: Ancient and Medieval 3 Units*Advisory: Eligibility for ENGL 100 C.*

Term hours: 48–54 lecture. This historical introduction to philosophy traces the development of Western philosophy from the early Greeks through the Medieval Period. The ideas which have influenced the development of Western culture are emphasized. This course will explore the birth of rational thought with the PreSocratics, such as Anaximander, Heraclitus, the Pythagoreans, Parmenides, Empedocles, and the Greek atomists, then move to Athens with Socrates, Plato, and Aristotle, and continue with philosophers from the late Classical and Medieval periods with special emphasis on the Stoics, the Skeptics, Augustine, Aquinas, and Ockham. This course surveys the development and transformation of Greek and Hellenistic metaphysics, epistemology, and ethics within the context of later philosophical theology. Emphasis will be placed on viewing these periods from the historical and cultural setting of the texts, which is relevant to many of the significant religious and philosophical issues facing us now, including the perennial search for values. (UC/CSU, AA GE, CSU GE, IGETC)

PHIL 202 C History of Philosophy: Modern and Contemporary 3 Units*Advisory: Eligibility for ENGL 100 C.*

Term hours: 48–54 lecture. This is a survey of Western philosophical thought from the Renaissance to the present. The course emphasizes metaphysics, theory of knowledge, and ethics, but may also include the development of views on political philosophy, God's existence, skepticism, empiricism, limits of human knowledge, causality, logic, semantics, and philosophical foundations of modern science. The course also examines the influence of past philosophical movements on modern life, including the growth of science and social and cultural changes. (UC/CSU, AA GE, CSU GE, IGETC)

PHIL 230 C Philosophy of Religion 3 Units

Term hours: 48–54 lecture. This course critically examines the central arguments for and against the existence of God, the historicity of miracles, and the possibility of life after death. (UC/CSU, AA GE, CSU GE, IGETC)

PHIL 240 C Jesus and His Interpreters 3 Units

Formerly PHIL 225 C.

Term hours: 48–54 lecture. This course focuses upon the ways in which Jesus is depicted in the Gospels and critically reconstructed in New Testament scholarship, with a view to determining what can be known historically regarding Jesus' teaching and life. (UC/CSU, CSU GE, IGETC)

PHIL 298 C Philosophy Seminar .5 to 12 Units*Prerequisite: May be required.**Corequisite: May be required.**Advisory: May be required.*

Term hours: 0–216 lecture and/or 0–432 laboratory depending on units attempted. This is a lecture/discussion type course developed on a particular limited problem or topic of interest to students. It is designed for able students who wish to increase their knowledge of a particular topic concerning which no other regular class is offered. A paper or group activity may be requested. Credit may range from .5 units to 12 units. Consult class schedule for the offerings a particular semester. May be taken for credit 1–4 times. Pass/No or Pass/No Pass/Letter Grade Option or Standard Letter Grade. Fees may be required — Payable at Registration. (UC Credit Limitation/CSU)

PHIL 299 C Philosophy Independent Study 1 Unit*Prerequisite: Approved Independent Study Learning Contract.*

Varying hours of scheduled conferences per week according to instructor. Independent study is for able students who wish to extend their knowledge of a particular area through individual research and study. It is thought that topics might develop out of a curiosity stimulated in a regular class. The student would then contact the supervising instructor to develop a contract for his/her particular interest so that they could learn more regarding their special topic. May be taken for credit 3 times. (UC Credit Limitation/CSU)

Photography

Division of Fine Arts

Division Dean — Ting-Pi (Joyce) Carrigan*Faculty*

Robert Johnson

Clifford Lester

Counselors

Renay Laguana-Ferinac

Renee Ssensalo

PROGRAM LEARNING OUTCOMES (PLOs)

A student who completes the Photography program of study will be able to:

- Produce photographic images utilizing a variety of photographic processes.
- Develop and create a portfolio of images centered on a single theme or idea.
- Possess the technical skills necessary to create professional quality photographs in both studio and location environments.
- Possess an understanding of how issues and concepts are related to the processes used to communicate them.

**ASSOCIATE IN ARTS DEGREE
PHOTOGRAPHY** **Program Code: 1A03782**

This program is designed to prepare students for entry into occupational photographic fields. A student may also elect to work toward a transfer into a four-year institution, in the field of Fine Arts.

To earn an Associate Degree students must complete: (1) all major course requirements with a minimum grade of “C”; (2) 25 units of General Education Graduation Requirements; (3) the cultural diversity and reading requirements; (4) any elective courses to complete a minimum of 60 units; and, (5) have a minimum GPA of 2.0. At least 50% of all major course work must be completed at Cypress College.

Courses that fulfill major requirements for an Associate Degree at Cypress College might not be the same as those required for completing the major at a transfer institution offering a Baccalaureate Degree. For information on specific university requirements, please consult with your counselor, or visit the Transfer Center.

Required courses are listed in suggested sequence:		Units
PHOT 101 C	Introduction to Photography	3
PHOT 103 C	Intermediate Photography	3
PHOT 104 C	Wedding and Event Photography	3
PHOT 109 C	Portrait Photography	3
PHOT 200 C	Conceptual Photography	3
PHOT 201 C	Intro to Professional Photo	3
PHOT 202 C	Contemporary Photography	3
PHOT 203 C	Studio Lighting Techniques	3
PHOT 204 C	History/Aesthetics of Photo	3
PHOT 207 C	Color Photography	3
PHOT 209 C	Careers in Photography	3
PHOT 215 C	Digital Photography	3
PHOT 216 C	Advanced Digital Photography	3
PHOT 219 C	Press Photography	3
PHOT 227 C	Digital Capture Workflow	3

Electives:		Units
ART 120 C*	Two-Dimensional Design	3
ART 182 C	Freehand Drawing	3
MGT 161 C	Introduction to Business	3
MGT 261 C	Small Business Management	3
MGT 266 C	Human Relations in Business	3
MKT 103 C	Principles of Advertising	3
MKT 208 C*	Principles of Selling	3
Total Units		45

*Recommended elective

**ADVERTISING AND ILLUSTRATIVE PHOTOGRAPHY
CERTIFICATE** **Program Code: 1K15692**

The Advertising and Illustrative Photography Certificate is designed to prepare students for starting their own business or for employment within the advertising industry.

To earn a certificate, students must complete the required courses as listed with a minimum grade of “C.” At least 50% of all course work must be completed at Cypress College.

Required courses are listed in suggested sequence:		
Course#	Title	Units
PHOT 201 C	Intro to Professional Photo	3
PHOT 203 C	Lighting and Studio Practices	3
PHOT 206 C	Studio Practices	3
Select a minimum of 6 units from the electives listed below		6
Total Units Required		15
Electives:		
PHOT 207 C	Color Photography	3
PHOT 209 C	Careers in Photography	3
PHOT 215 C	Digital Photography	3

**COLOR PHOTOGRAPHY
CERTIFICATE** **Program Code: 1C13042**

The Color Photography Certificate is designed to prepare the student for entry-level employment within the Photo Lab/Service Bureau industry. Students are trained in the use of state-of-the-art printing and processing equipment.

To earn a certificate, students must complete the required courses as listed with a minimum grade of “C.” At least 50% of all course work must be completed at Cypress College.

Required courses are listed in suggested sequence:		
Course #	Title	Units
PHOT 101 C	Introduction to Photography	3
PHOT 103 C	Photographic Possibilities	3
PHOT 207 C	Color Photography	3
PHOT 208 C	Advanced Color Photography	3
PHOT 215 C	Digital Photography	3
PHOT 216 C	Advanced Digital Photography	3
Total Units Required		18

**CREATIVE PHOTO ARTS
CERTIFICATE** **Program Code: 1K15691**

The Creative Photo Arts Certificate is designed to prepare students for a career as an individual artist or as an employee in the visual arts.

To earn a certificate, students must complete the required courses as listed with a minimum grade of “C.” At least 50% of all course work must be completed at Cypress College.

Required courses are listed in suggested sequence:		
Course#	Title	Units
PHOT 200 C	Conceptual Photography	3
PHOT 202 C	Contemporary Photography	3
PHOT 204 C	History Aesthetics of Photo	3
Select a minimum of 6 units from the electives listed below		6
Total Units Required		15

Electives:		
PHOT 207 C	Color Photography	3
PHOT 215 C	Digital Photography	3
PHOT 220 C	Alternative Photographic Processes	3

**DIGITAL PHOTOGRAPHY
CERTIFICATE****Program Code: 1K12978**

The Digital Photography Certificate is designed to prepare the student for entry-level employment within the Photo Lab/Service Bureau Industry. Students are trained in the use of state-of-the-art printing and processing equipment.

To earn a certificate, students must complete the required courses as listed with a minimum grade of "C." At least 50% of all course work must be completed at Cypress College.

Required courses are listed in suggested sequence:

Course#	Title	Units
PHOT 207 C	Color Photography	3
PHOT 215 C	Digital Photography	3
PHOT 216 C	Advanced Digital Photography	3
PHOT 217 C	3D Photo Imaging	3
Total Units Required		12

**DIGITAL PHOTO
TECHNICIAN****Program Code: 1C30327**

This certificate is a comprehensive series of courses designed to prepare students for employment in the profession of Digital Photo Technician. Courses will include in depth study of color, high end digital camera operation, computer technology, digital capture workflow, studio lighting, and studio set etiquette.

Required courses are listed in numeric sequence:

	Units	
PHOT 215 C	Digital Photography	3
PHOT 216 C	Advanced Digital Photography	3
PHOT 203 C	Lighting and Studio Techniques	3
PHOT 207 C	Color Photography	3
PHOT 227 C	Digital Capture Workflow	3
PHOT 230 C	Adv. Digital Capture Workflow	3
Total Units		18

**MULTIMEDIA PHOTOGRAPHY
CERTIFICATE****Program Code: 1C13043**

This certificate is designed to prepare the student to work with a variety of photographically based digital applications within the field of Multimedia. This flexible module allows the student to develop their own emphasis within the possible course offerings.

To earn a certificate, complete the required major courses as listed with a minimum grade of "C." At least 50% of all course work must be completed at Cypress College.

Required courses are listed in suggested sequence:

	Units	
MM 100 C	Introduction to Multimedia	3
MM 110 C	Visual Communication	3
PHOT 101 C	Introduction to Photography	3
PHOT 103 C	Intermediate Photography	3
PHOT 207 C	Color Photography	3
PHOT 209 C	Careers in Photography	3
PHOT 215 C	Digital Photography	3
PHOT 216 C	Advanced Digital Photography	3
PHOT 227 C	Digital Capture Workflow	3

Any one of the following may be substituted for the above except PHOT 103 C, PHOT 215 C, PHOT 207 C because these are prerequisite courses:

	Units	
PHOT 050 C	Photography — Special Projects	3
PHOT 104 C	Wedding and Event Photography	3
PHOT 109 C	Portrait Photography	3
PHOT 200 C	Conceptual Photography	3
PHOT 219 C	Press Photography	3
Total Units		27

**PHOTOGRAPHY
CERTIFICATE****Program Code: 1C21111**

The certificate program in photography allows the student to prepare for entry into an occupational photographic field.

To earn a certificate, complete the required courses listed below, plus 3 additional units from the list of suggested electives listed below with a minimum grade of "C." At least 50% of all course work must be completed at Cypress College.

Required courses are listed in suggested sequence:

	Units	
PHOT 101 C	Introduction to Photography	3
PHOT 103 C	Intermediate Photography	3
PHOT 109 C	Portrait Photography	3
PHOT 201 C	Intro to Professional Photo	3
PHOT 207 C	Color Photography	3
PHOT 209 C	Careers in Photography	3
PHOT 215 C	Digital Photography	3

Electives:**Select a minimum of 3 units from the electives below**

	Units	
PHOT 208 C	Advanced Color Photography	3
PHOT 216 C	Advanced Digital Photography	3
PHOT 217 C	3D Photo Imaging	3
ART 120 C	Two-Dimensional Design	3
*ART 182 C	Freehand Drawing	3
ENGL 095 C	Effective Writing	3
MGT 161 C	Introduction to Business	3
MGT 261 C	Small Business Management	3
MGT 266 C	Human Relations in Business	3
MKT 103 C	Principles of Advertising	3
MKT 208 C	Principles of Selling	3
Total Units		24

*A score of 3 or higher on the Advanced Placement (AP) Art (Studio Drawing) exam meets this requirement upon petition through Admissions and Records. See a counselor for more information.

**PORTRAIT AND WEDDING PHOTOGRAPHY
CERTIFICATE****Program Code: 1K12984**

The Portrait and Wedding Photography Certificate is designed to prepare students for starting their own business or for employment within the wedding/portrait industry.

To earn a certificate, students must complete the required courses as listed with a minimum grade of "C." At least 50% of all course work must be completed at Cypress College.

Required courses are listed in numeric sequence:

	Units	
PHOT 104 C	Wedding and Event Photography	3
PHOT 109 C	Portrait Photography	3
PHOT 207 C	Color Photography	3
PHOT 209 C	Careers in Photography	3
PHOT 215 C	Digital Photography	3
Total Units		15

PHOTOGRAPHY TRANSFER PROGRAM

Students should consult a counselor or www.assist.org for lower division major requirements for most California public universities. (See the Standard Definitions section of the catalog for a description of ASSIST.) Students transferring to an independent college/university should consult the catalog of the individual school and a counselor for lower division major requirements.

Photography (PHOT)

PHOT 050 C Photography Special Projects 3 Units

Advisory: PHOT 103 C.

Term hours: 32–36 lecture and 64–72 laboratory TBA. Designed to allow the student to specialize in one particular phase of photography under the close supervision of the instructor. Students will be required to meet periodic deadlines and do some classroom assignments that are loosely structured to allow creativity. This should be the final class that the student takes before leaving the photography program. May be taken for credit 3 times. \$20.00 Material Fee — Payable at Registration.

PHOT 055 C Photography — Work Experience — Vocational 1 to 4 Units

Prerequisite: Must be enrolled in seven units, including work experience.

Term hours: 16–18 lecture and 80–90 hours of supervised employment in a photographic occupation for each unit of credit. Concurrent enrollment in Photography Program. The course requires a minimum of five hours employment in a photography related occupation per week. Refer to class schedule for an explanation of unit credit. May be taken for credit 4 times.

PHOT 101 C Introduction to Photography 3 Units

Term hours: 32–36 lecture and 64–72 laboratory TBA. This course provides students with an introduction to visual concepts, basic image capture and camera functions with film and digital cameras. Software basics for photographic imaging and digital printing, along with traditional black and white darkroom printing will be taught. \$20.00 Material Fee — Payable at Registration. Credit by Examination. (UC/CSU, AA GE, CSU GE)

PHOT 103 C Intermediate Photography 3 Units

Advisory: PHOT 101 C.

Term hours: 32–36 lecture and 64–72 laboratory TBA. This course is designed to reinforce and enhance the concepts and skills acquired to the Introduction to Photography class. The emphasis will be on the refinement of basic technical skills including black and white processing and printing, film and digital camera operation, basic scanning and image software techniques, and the development of a personal direction in photography for each student. In order to increase the student's exposure to the medium, the course also includes an introduction to large format cameras and studio lighting. \$20.00 Material Fee — Payable at Registration. (CSU)

PHOT 104 C Wedding and Event Photography 3 Units

Advisory: PHOT 103 C.

Term hours: 32–36 lecture and 48–54 laboratory TBA. This course is designed to acquaint the student with the fundamental concepts, equipment demands, and photographic techniques used by contemporary event, special occasion and wedding photographers. The course is composed of lectures and outside assignments which will prepare the students for basic application in this field of photography. May be taken for credit 3 times. \$20.00 Material Fee — Payable at Registration. (CSU)

PHOT 109 C Portrait Photography 3 Units

Advisory: PHOT 103 C.

Term hours: 32–36 lecture and 48–54 laboratory TBA. This course is designed to give the student a working knowledge of portrait styles and techniques. The student will practice techniques for photographing people in a studio and on location situation. The student will work with both natural and artificial lighting and learn the possibilities and limitations of both. Camera formats will range from 35mm to 4x5 and digital still and video. Students will have an opportunity to investigate and imitate the styles of well-known portrait photographers. May be taken for credit 3 times. \$20.00 Material Fee — Payable at Registration. (CSU)

PHOT 118 C Available Light Photography 3 Units

Advisory: PHOT 101 C and PHOT 103 C.

Term hours: 32–36 lecture and 64–72 laboratory TBA. This course is designed to give the student knowledge of and competency in making images in situations where lighting cannot be rigidly controlled. Combining lighting awareness with creative camera, darkroom, and digital photography techniques, the course concentrates on the production and processing of photographic images made under a variety of lighting conditions found in both natural and man made environments. Topics include selection and care of equipment, use of filters for both black and white or color images, techniques for photographing both at night and during the day, and techniques for photographing indoors without strobe equipment. May be taken for credit 3 times. \$35.00 Materials Fee — Payable at Registration. (CSU)

PHOT 200 C Conceptual Photography 3 Units

Prerequisite: PHOT 103 C with a minimum grade of "C."

Term hours: 32–36 lecture and 64–72 laboratory TBA. This course is designed to give the student a thorough understanding of how issues and concepts are related to the processes used to communicate them. The student will become familiar with major artists whose work employs non-traditional processes. The thrust of the course work will revolve around the different ways that a variety of processes can be used to communicate ideas. May be taken for credit 3 times. \$20.00 Material Fee — Payable at Registration. (CSU)

PHOT 201 C Introduction to Professional Photo 3 Units

Advisory: PHOT 103 C.

Term hours: 32–36 lecture and 64–72 laboratory TBA. This is a course dealing with the production of photographs for advertising and editorial use. Emphasis will be placed on advanced studio techniques, as well as the conceptual validity of photographs for industry applications. May be taken for credit 3 times. May be taken for credit 3 times. \$20.00 Material Fee — Payable at Registration. (CSU)

PHOT 202 C Contemporary Photography 3 Units

Prerequisite: PHOT 103 C with a grade of "C" or better.

Term hours: 32–36 lecture and 64–72 laboratory TBA. This is a course designed to give advanced students a thorough understanding of the concepts and concerns of contemporary photography, its roots and future directions. The student will become familiar with the course work of major artists working after 1950. The major thrust of the course work will be focused on understanding why photographs are done and what they communicate. Assignments will be done in the process(es) of the student's choice based on its relevance to the ideas expressed. May be taken for credit 3 times. \$20.00 Material Fee — Payable at Registration. (UC Credit Limitation/CSU)

PHOT 203 C Studio Lighting Techniques 3 Units

Advisory: PHOT 103 C.

Term hours: 32–36 lecture and 64–72 laboratory TBA. This course acquaints the student with lighting and studio techniques as commonly used in professional photographic applications. The emphasis will be on light and the use of lighting equipment in both studio and location situations. May be taken for credit 3 times. \$20.00 Material Fee — Payable at Registration. (CSU)

PHOT 204 C History and Aesthetics of Early Photographic Practice**3 Units***Advisory: PHOT 103 C.*

Term hours: 32–36 lecture and 64–72 laboratory TBA. This is a lecture/lab course on the history of photography that is designed to give students a practical knowledge of the development of the medium through a combination of lecture and hands-on technical and aesthetic experiences utilizing early photographic techniques and processes. The course will emphasize the invention and development of photography from its inception in the early 1800s through the early 1950s. \$20.00 Material Fee — Payable at Registration. (UC/CSU)

PHOT 206 C Studio Practices**3 Units***Advisory: PHOT 103.*

Term hours: 32–36 lecture and 64–72 laboratory TBA. This is a course designed to familiarize the student with image conceptualization and the differing technical alternatives used in commercial studio photography. Students will learn specialized professional camera and digital imaging techniques utilized by professional studio photographers. May be taken for credit 3 times. \$20.00 Materials Fee — Payable at Registration. (CSU)

PHOT 207 C Color Photography**3 Units***Advisory: PHOT 103 C.*

Term hours: 32–36 lecture and 64–72 laboratory TBA. The course is designed for the advanced student and provides a solid background in the theory and practice of color photography. Students will explore the possibilities and limitations of traditional and digital color processes, including color negative and color positive printing methods. Emphasis will be placed on both technical and aesthetic expression of color, from initial capture to finished print, along with color symbolism and its use as a compositional tool. May be taken for credit 3 times. \$35.00 Materials Fee — Payable at Registration. (CSU)

PHOT 209 C Careers in Photography**3 Units***Advisory: PHOT 103 C.*

Term hours: 32–36 lecture and 64–72 laboratory TBA. This course is designed to help students identify and achieve professional goals and objectives. The course will provide an understanding of the various career options within the field and the level of professional preparation that is necessary in order to get established in a particular career area. Topics will include the technical skills, equipment, portfolio development, promotional needs and specialized business considerations necessary for getting a job or establishing a photographic business. \$20.00 Material Fee — Payable at Registration. (CSU)

PHOT 211 C Zone System Photography**3 Units***Advisory: PHOT 103 C.*

Term hours: 32–36 lecture and 64–72 laboratory TBA. This is a course emphasizing the zone system of exposure control. This method of exposure is used to control final image quality under normal and adverse applications. Both film and digital imaging will be emphasized. May be taken for credit 3 times. \$35.00 Material Fee — Payable at Registration. (CSU)

PHOT 215 C Digital Photography**3 Units***Advisory: PHOT 103 C.*

Term hours: 32–36 lecture and 64–72 laboratory TBA. This course is designed to integrate digital imaging into the advanced photography student's visual repertoire. Combining creative studio/camera practices with computer technology, the course concentrates on the production and processing of images with current digital media to all areas of photography (commercial, illustration, portraiture, journalism, industrial, scientific, etc.). Included are techniques for background control, selection and manipulation, digitization, image capture and processing. May be taken for credit 3 times. \$35.00 Materials Fee — Payable at Registration. (CSU)

PHOT 216 C Advanced Digital Photography**3 Units***Advisory: PHOT 103 C.*

Term hours: 32–36 lecture and 64–72 laboratory TBA. This course is designed to provide the student with advanced knowledge of techniques and skills in the application of digital technologies to all areas of the photographic medium. The integration of technical skills and aesthetic expression will be emphasized along with advanced color management and printing techniques. Projects will require exploration and experimentation integrating digital image making into the creative process. Students develop the skills necessary to create their own unique body of work using digital photographic technologies. May be taken for credit 3 times. \$35.00 Material Fee — Payable at Registration. (CSU)

PHOT 217 C 3D Photo Imaging**3 Units***Prerequisite: PHOT 103 C with a grade of "C" or better.*

Term hours: 32–36 lecture and 64–72 laboratory TBA. This course is designed to provide the student with advanced knowledge of 3D photographic imaging technologies as they relate to the study of light, form, and three-dimensional space. Students will study lighting, form, and space in virtual environments of their own creation. A diverse assortment of 3D software will be utilized to instruct students in how forms are visually perceived and modified based on the way light describes them. The relationship between 2D and 3D imaging applications will be discussed as well as the integration of the two for a variety of commercial photography and multimedia applications. These include studio background creation, special visual effects, game production, photo illustration, and digital composites. May be taken for credit 3 times. \$35.00 Materials Fee — Payable at Registration. (CSU)

PHOT 219 C Editorial Photography**3 Units***Advisory: PHOT 103 C.*

Term hours: 32–36 lecture and 64–72 laboratory TBA. This course is designed to acquaint the student with a current view of the field of photojournalism and photographic publishing for magazines, the Internet, and all editorial uses. Heavy emphasis is placed on communication through photography. May be taken for credit 3 times. \$20.00 Material Fee — Payable at Registration. (CSU)

PHOT 220 C Alternative Photo Processes**3 Units***Advisory: PHOT 103 C.*

Term hours: 32–36 lecture and 64–72 laboratory TBA. This class will investigate the artistic aspects and technical procedures used in 19th Century photographic printing of hand coated papers. Class projects will include aspects of graphic arts photography, films and developers. During the semester, students will work with cyanotypes, Kallitypes and kwik print. May be taken for credit 3 times. \$35.00 Material Fee — Payable at Registration. (CSU)

PHOT 227 C Digital Capture Workflow**3 Units***Advisory: PHOT 101 C, PHOT 103 C, PHOT 215 C and PHOT 216 C.*

Term hours: 32–36 lecture and 64–72 laboratory TBA. This workflow based class will provide a foundation for capturing and processing Raw digital photo files with the latest prevailing high end digital imaging hardware and software. The course will be centered around using software such as Adobe Lightroom to create optimal digital files. Students will have the opportunity to gain hands on experience with various professional camera platforms such as Leaf and Phase. They will develop the skills necessary to work effectively with their own digital files as a professional photographer or in a support capacity such as a digital photo technician. May be taken for credit 3 times. \$35.00 Material Fee — Payable at Registration. (CSU)

PHOT 230 C Advanced Digital Capture Workflow 3 Units

Advisory: PHOT 227 C.

Term hours: 32–36 lecture and 64–72 laboratory TBA. This course will allow students to work hands on with 35mm and 2¼ digital camera systems, building upon the skills learned in Digital Camera Workflow. Practical application of tethered photography using the camera manufacturer software in conjunction with Adobe Lightroom will be the focus. Students will have the opportunity to gain organizational skills such as file naming, shot folder hierarchy and metadata strategies. Monitor and camera calibration as well as basic computer and camera troubleshooting techniques will be taught. Through guest speakers and a set visit, they will gain valuable insights about how to work professionally as a photographer or digital tech. May be taken for credit 3 times. \$35.00 Material Fee — Payable at Registration. (CSU)

PHOT 298 C Photography Seminar .5 to 12 Units

Prerequisite: May be required.

Corequisite: May be required.

Advisory: May be required.

Term hours: 0–216 lecture and 0–1080 laboratory depending on units attempted. This is a course for students who wish to increase their knowledge of photography. Various topics will be offered. Unit credit may range from .5 to 12 units in any given semester. Consult the class schedule to verify credit for a particular semester. May be taken for credit 1–4 times. Pass/No Pass or Pass/No Pass/Letter Grade Option or Standard Letter Grade. Fees may be required — Payable at Registration. (CSU)

Physical Education

Division of Physical Education and Athletics

Division Dean — Diane Henry

Faculty

- Larry Beidler
- Paul Bottiaux
- Margaret Mohr
- Brad Pickler
- Scott Pickler
- Bill Pinkham
- Nancy Welliver

Counselor

Dana Bedard

PROGRAM LEARNING OUTCOMES (PLOs)

The courses taught by this department contribute to the General Education and Basic Skills Program Learning Outcomes. Please refer to General Education and Basic Skills Program Learning Outcomes.

Athletics

Students who complete the Athletics program will be:

- Prepared to transfer to a 4-year College/University.
- Able to acquire cognitive knowledge and physical skills to improve performance.

Professional/Career

Students who complete the Professional/Career program will be able to:

- Enhance their professional career opportunities in the area of physical education.
- Acquire the theory and practical skills related to the physical education activities.
- Acquire the theory and knowledge in the field of physical education.

ASSOCIATE IN ARTS DEGREE

PHYSICAL EDUCATION Program Code: 1A03769

This program is designed to prepare students with a knowledgeable base of physical fitness, health practices, and professional activities for entry into the discipline of physical education/athletics. Further specialization is possible by combining the Associate of Arts Degree with electives chosen from a certificate program in aerobics, aquatics, or coaching. A student may also elect to work toward a transfer program preparing for entry to a four-year institution.

To earn an Associate Degree students must complete: (1) all major course requirements with a minimum grade of “C”; (2) 25 units of General Education Graduation Requirements; (3) the cultural diversity and reading requirements; (4) any elective courses to complete a minimum of 60 units; and, (5) have a minimum GPA of 2.0. At least 50% of all major course work must be completed at Cypress College.

Courses that fulfill major requirements for an Associate Degree at Cypress College might not be the same as those required for completing the major at a transfer institution offering a Baccalaureate Degree. For information on specific university requirements, please consult with your counselor, or visit the Transfer Center.

Required courses are listed in suggested sequence:

Course #	Title	Units
*BIOL 101 C	General Biology	5
	or	
BIOL 102 C	Human Biology	(3)
	or	
BIOL 160 C	Integrated Medical Science	(3)
	or	
BIOL 210 C	Anatomy and Physiology	(5)
	or	
BIOL 231 C	General Human Anatomy	(4)
PE 234 C	Contemporary Personal Health	3
	or	
PE 244 C	Human Performance	(3)
PE 235 C	First Aid, CPR and Emergencies	3
	or	
PE 250 C	Sport and United States Society	(3)

Electives

Choose one of the following:

PE 231 C	Elementary School Movement — PE	3
PE 236 C	Prev and Care/Athletic Injuries	3
PE 240 C	Sports Management	3
PE 244 C	Human Performance	3
PE 248 C	Psychology of Sport	3
PE 252 C	Intro to Kinesiology	3
PE 266 C	Theory of Coaching Basketball	3
PE 267 C	Theory of Coaching Baseball and	3

Choose at least 3 units from Physical Education activity courses

PE 100 C–PE 222 C

or

Any Pro Activities courses

PE 261 C–PE 263 C,

PE 280 C–PE 286 C

Total Units Required**18–21**

*A score of 3 or higher on the Advanced Placement (AP) Biology exam meets this requirement upon petition through Admissions and Records. See a counselor for more information.

AEROBIC INSTRUCTOR**CERTIFICATE****Program Code: 1C07828**

Primary emphasis is to prepare the student for occupational competency in aerobic exercise instruction for corporate fitness or health clubs. All students must complete 18 units. Course work in PE 235 C may be waived with current Red Cross cards in First Aid and CPR at the discretion of the division.

To earn a certificate, students must complete the required courses as listed with a minimum grade of “C.” At least 50% of all course work must be completed at Cypress College.

Required courses are listed in suggested sequence:

Course #	Title	Units
PE 161 C	Body Conditioning and Fitness	1
	or	
PE 178 C	Core Strength and Stability	(1)
PE 129 C	Step Aerobics	1
PE 235 C	First Aid, CPR and Emergencies	3
	or	
PE 236 C	Prev and Care/Athletic Injuries	(3)
PE 244 C	Human Performance	3
	or	
PE 234 C	Contemporary Personal Health	(3)
PE 299 C	Physical Education — Independent Study	2

Select a minimum of 8 units from the electives listed below:

PE 148 C	Low-Impact Aerobics	1
PE 152 C	Fitness Training Lab	.5–2
PE 252 C	Intro to Kinesiology	3
PE 114 C	Cardiovascular Conditioning	1
PE 150 C	Rhythmic Aerobic Exercise	1
PE 151 C	Water Aerobics/Pool Exercises	1
*BIOL 101 C	General Biology	5
	or	
BIOL 102 C	Human Biology	(3)
	or	
BIO: 160 C	Integrated Medical Science	(3)
	or	
BIOL 231 C	General Human Anatomy	(4)
HRC 100 C	Nutrition	3
Total Units Required		18

*A score of 3 or higher on the Advanced Placement (AP) Biology exam meets this requirement upon petition through Admissions and Records. See a counselor for more information.

AQUATICS SPECIALIST**CERTIFICATE****Program Code: 1C07829**

Primary emphasis is to prepare the student for occupational competency in swimming instruction as recommended by the state of California and the American Red Cross. All students must complete 18 units. Course work in PE 235 C, PE 237 C, and PE 238 C may be waived with current Red Cross cards in First Aid and CPR, Life Saving and Water Safety Instruction at the discretion of the division.

To earn a certificate, students must complete the required courses as listed with a minimum grade of “C.” At least 50% of all course work must be completed at Cypress College.

Required courses are listed in suggested sequence:

Course #	Title	Units
PE 135 C	Swimming — Intermed/Advanced	1
PE 235 C	First Aid, CPR, and Emergencies	3
PE 237 C	Lifesaving	1
PE 238 C	Water Safety Instruction	2
PE 299 C	Physical Education — Independent Study	1

Select a minimum of 9 units from the electives listed below

PE 136 C	Springboard Diving	1
PE 146 C	Water Polo	1
PE 149 C	Swim for Fitness	1
PE 151 C	Water Aerobics/Pool Exercises	1
PE 152 C	Fitness Training Lab	.5–2
PE 247 C	Sports Management	3
PE 248 C	Psychology of Sport	3
PE 239 C	Skin and Scuba Diving	3
*BIOL 101 C	General Biology	5
	or	
BIOL 102 C	Human Biology	(3)
	or	
BIOL 160 C	Integrated Medical Science	(3)
	or	
BIOL 231 C	General Human Anatomy	(4)

Total Units Required**17**

*A score of 3 or higher on the Advanced Placement (AP) Biology exam meets this requirement upon petition through Admissions and Records. See a counselor for more information.

ATHLETIC COACH**CERTIFICATE****Program Code: 1C07830**

Primary emphasis is to prepare the student for occupational coaching at various levels. All students must complete 18 units. Course work in PE 235 C may be waived with current Red Cross cards in First Aid and CPR at the discretion of the division.

To earn a certificate, students must complete the required courses as listed with a minimum grade of “C.” At least 50% of all course work must be completed at Cypress College.

Required courses are listed in suggested sequence:

Course #	Title	Units
PE 235 C	First Aid, CPR, and Emergencies or	3
PE 236 C	Prev and Care/Athletic Injuries	(3)
PE 244 C	Human Performance or	3
PE 234 C	Contemporary Personal Health	(3)
PE 248 C	Psychology of Sport	3
PE 261 C	Pro Activities — Tennis or	2
PE 281 C	Pro Activities — Basketball or	(2)
PE 280 C	Pro Activities — Baseball or	(2)
PE 282 C	Pro Activities — Softball or	(2)
PE 284 C	Pro Activities — Soccer or	(2)
PE 262 C	Pro Activities — Volleyball (Coed)	(2)
PE 266 C	Theory of Coaching Basketball or	3
PE 267 C	Theory of Coaching Baseball	(3)
A minimum of 4 units from the electives listed below		
PE 252 C	Intro to Kinesiology	3
PE 240 C	Sports Officiating	3
PE 250 C	Sport and United States Society	3
PE 299 C	Physical Education Indep Study	.5–2
PE 152 C	Fitness Training Lab	2
PE 247 C	Sports Management	3
PE 231 C	Elementary School Movement — PE	3
Total Units Required		18

PHYSICAL EDUCATION TRANSFER PROGRAM

Students should consult a counselor or www.assist.org for lower division major requirements for most California public universities. (See the Standard Definitions section of the catalog for a description of ASSIST.) Students transferring to an independent college/university should consult the catalog of the individual school and a counselor for lower division major requirements.

Physical Education (PE)

PE 100 C Adaptive P.E. — Weight Training .5 to 1 Units

Prerequisite: This course is expressly designed for, but not limited to, students with permanent disability.

Term hours: 24–54 hours activity depending on units attempted. This course is designed to give students with a disability the opportunity to participate in resistive exercises with weights. May be taken for credit 4 times. (UC Credit Limitation/CSU, AA GE, CSU GE)

PE 101 C Adaptive P.E. — Activity .5 to 1 Units

Prerequisite: This course is expressly designed for, but not limited to, students with permanent disability.

Term hours: 24–54 hours activity depending on units attempted. This course is designed for the disabled student. The class will emphasize modified individual and team sport activities. May be taken for credit 4 times. (UC Credit Limitation/CSU, AA GE, CSU GE)

PE 102 C Yoga .5 to 1 Units

Term hours: 24–54 hours activity depending on units attempted. This is an overview course in yoga, an integrated study of health. It involves the investigation and practice of breathing techniques, yoga postures (asanas), and meditation and relaxation. Emphasis is on practicing the principles of pranayama (breathing) and deep relaxation to reduce stress, improving concentration, circulation and flexibility, and unifying body, mind and spirit. The yoga portion will also help to tone and strengthen muscles. May be taken for credit 4 times. (UC Credit Limitation/CSU, AA GE, CSU GE)

PE 104 C Athletic Weight Training .5 to 2 Units

Term hours: 24–108 hours activity depending on units attempted. This course is designed with athletes in mind, but not limited to them, to enable them to work out with a prescribed individual weight program at least three days a week. It will involve specific resistance exercises to develop parts of the body used in various types of sports activities. It will also add to the safety of the athletes by helping to prevent injuries. May be taken for credit 4 times. (UC Credit Limitation/CSU, AA GE, CSU GE)

PE 105 C Badminton .5 to 1 Units

Term hours: 24–54 hours activity depending on units attempted. This is a course in the fundamental skills of badminton with emphasis on position play and strategy for singles, doubles, and mixed doubles. The class will include rules, etiquette, drills, and class competition. Equipment is furnished. May be taken for credit 4 times. (UC Credit Limitation/CSU, AA GE, CSU GE)

PE 107 C Table Tennis .5 to 1 Units

Term hours: 24–54 hours activity depending on units attempted. This course will consist of essential strokes with emphasis on the game strategies for singles and doubles play of table tennis. Rules, etiquette and tournament format will be introduced to the class. May be taken for credit 4 times. (UC Credit Limitation/CSU, AA GE, CSU GE)

PE 108 C Bowling .5 to 1 Units

Term hours: 24–54 hours activity depending on units attempted. This course teaches the fundamental skills of bowling with emphasis on form, terminology and scoring. The student will have the opportunity for class competition. The class will be conducted at an off campus bowling establishment. Facility use fee required. To be paid throughout the semester at the facility. May be taken for credit 4 times. (UC Credit Limitation/CSU, AA GE, CSU GE)

PE 109 C Futsal (Indoor Soccer) .5 to 1 Units

Term hours: 24–54 hours activity depending on units attempted. The class will provide instruction and practice in the techniques of futsal (indoor soccer). This course will develop skills, provide knowledge of the rules and teach students to analyze techniques, solve tactical problems and improve physical fitness. May be taken for credit 4 times. (UC Credit Limitation/CSU, AA GE, CSU GE)

PE 114 C Cardiovascular Conditioning .5 to 1 Units

Term hours: 24–54 hours activity depending on units attempted. This class is designed to provide an individualized exercise program for the student interested in achieving physical fitness through a program of cardiovascular conditioning. May be taken for credit 4 times. (UC Credit Limitation/CSU, AA GE, CSU GE)

PE 115 C Golf — Beginning .5 to 1 Units

Term hours: 24–54 hours activity depending on units attempted. This course emphasizes the basic fundamentals of golf, including rules, etiquette, and terminology. Golfing activity will be held at an on-campus location for the first half of the class. The second half of the class will be held at an off-campus golf facility. Facility use fee required. To be paid throughout the semester at the facility. May be taken for credit 4 times. (UC Credit Limitation/CSU, AA GE, CSU GE)

PE 117 C Gymnastics .5 to 1 Units

Term hours: 24–54 hours activity depending on units attempted. This course is designed to teach basic skills and knowledge necessary to the performance of gymnastic stunts. The class develops agility, balance, timing, flexibility, and strength. May be taken for credit 4 times. (UC Credit Limitation/CSU, AA GE, CSU GE)

PE 118 C Gymnastics Apparatus .5 to 1 Units

Term hours: 24–54 hours activity depending on units attempted. This course is designed to give the student concentrated instruction and practice on the uneven bars, horizontal bar, parallel bars, balance beam, side horse, vaulting, and rings. May be taken for credit 4 times. (UC Credit Limitation/CSU, AA GE, CSU GE)

PE 119 C Gymnastics — Tumbling .5 to 1 Units

Term hours: 24–54 hours activity depending on units attempted. This course is designed to give the student concentrated instruction and practice in the skills of tumbling, floor exercises, and vaulting skills. May be taken for credit 4 times. (UC Credit Limitation/CSU, AA GE, CSU GE)

PE 121 C Walking for Fitness .5 to 1 Units

Term hours: 24–54 hours activity depending on units attempted. This course will emphasize walking for health and fitness for men and women who are interested in instruction and practice in cardiovascular walking. This class is designed to decrease the risk of coronary heart disorders by increasing heart efficiency, vital lung capacity and the knowledge of each through aerobic and anaerobic conditioning. May be taken for credit 4 times. (UC Credit Limitation/CSU, AA GE, CSU GE)

PE 122 C Surfing .5 to 1 Units

Prerequisite: Demonstrate ability to swim.

Term hours: 24–54 hours activity depending on units attempted. This course offers students the opportunity to learn and improve the skills of wave riding. Examination and analysis of paddling, wave selection, water safety, equipment, tides, current, and etiquette are emphasized for long boarding and short boarding. Transportation will not be furnished. May be taken for credit 4 times. (UC Credit Limitation/CSU, AA GE, CSU GE)

PE 129 C Step Aerobics .5 to 1 Units

Term hours: 24–54 hours activity depending on units attempted. This course provides aerobic development through coordinated stepping movements performed to music. The class will emphasize cardiovascular improvement, muscle development, and decreased body fat. May be taken for credit 4 times. (UC Credit Limitation/CSU, AA GE, CSU GE)

PE 134 C Swimming .5 to 1 Units

Term hours: 24–54 hours activity depending on units attempted. This course provides basic instruction and practice in the fundamental elements of swimming including beginning diving and water safety instruction. The class is designed to develop proficiency in the basic strokes needed to meet the prerequisites for the senior lifesaving and water safety instruction courses. May be taken for credit 2 times. (UC Credit Limitation/CSU, AA GE, CSU GE)

PE 135 C Swimming — Intermediate/Advanced .5 to 1 Units

Prerequisite: Demonstrate ability to swim.

Term hours: 24–54 hours activity depending on units attempted. This course is designed to develop knowledge and skill in competitive swimming strokes. The swimming strokes to be taught are the American crawl, backstroke, breaststroke, and dolphin butterfly. The class will emphasize the development of cardiovascular aerobic conditioning. May be taken for credit 2 times. (UC Credit Limitation/CSU, AA GE, CSU GE)

PE 136 C Springboard Diving .5 to 1 Units

Prerequisite: Demonstrate ability to swim.

Term hours: 24–54 hours activity depending on units attempted. This course is designed to teach the fundamentals of springboard diving. The beginning diver will learn diving progression for the front, back, reverse, inward and twisting dives. May be taken for credit 4 times. (UC Credit Limitation/CSU, AA GE, CSU GE)

PE 139 C Tennis .5 to 1 Units

Term hours: 24–54 hours activity depending on units attempted. The course will place emphasis on tennis fundamentals including forehand, backhand and the serve. The course also includes rules, court strategy, and etiquette of singles and doubles play. Tournaments will be conducted during class sessions. Students must provide their own equipment. May be taken for credit 4 times. (UC Credit Limitation/CSU, AA GE, CSU GE)

PE 141 C Specialized Tennis Skills .5 to 1 Units

Term hours: 24–54 hours activity depending on units attempted. This class is designed for students desiring instruction from intermediate to advanced tennis. The class provides the opportunity to put techniques into practice through placement in the various levels of tennis ability. May be taken for credit 4 times. (UC Credit Limitation/CSU, AA GE, CSU GE)

PE 142 C Mountaineering/Rock Climbing .5 to 1 Units

Term hours: 24–54 hours activity depending on units attempted. This course is designed for those students wishing to develop beginning through advanced skills in mountaineering/rock climbing. Teaching emphasis is on preparation, knowledge of equipment, physical techniques, and the mental approach to climbing. Facility use fee required, to be paid throughout the semester at the facility. Subject to change by facility. May be taken for credit 4 times. (UC Credit Limitation/CSU, AA GE, CSU GE)

PE 144 C Volleyball .5 to 1 Units

Term hours: 24–54 hours activity depending on units attempted. The course will include teaching of the basic skills of volleyball with emphasis on strategy and rules. The students will be offered the opportunity for class and interclass competition. May be taken for credit 2 times. (UC Credit Limitation/CSU, AA GE, CSU GE)

PE 145 C Volleyball — Intermediate/Advanced .5 to 1 Units

Term hours: 24–54 hours activity depending on units attempted. This course is designed to provide advanced skill development and strategies of volleyball. This class will provide intermediate and advanced players an opportunity to practice competitive techniques in games situations. May be taken for credit 2 times. (UC Credit Limitation/CSU, AA GE, CSU GE)

PE 146 C Water Polo .5 to 1 Units

Prerequisite: Demonstrate ability to swim.

Term hours: 24–54 hours activity depending on units attempted. Basic instruction will be given in the fundamental skills of water polo. Instruction will emphasize passing, shooting, dribbling, conditioning, game strategy, and terminology. The course will include aquatic drills, scrimmages and appropriate learning activities for the intermediate and advanced water polo player. May be taken for credit 4 times. (UC Credit Limitation/CSU, AA GE, CSU GE)

PE 148 C Low-Impact Aerobics .5 to 1 Units

Term hours: 24–54 hours activity depending on units attempted. This course provides an aerobic workout without jogging, running, jumping or other high impact type movements which might result in overstress to feet, ankles, knees, hips or the spinal column. The exercise sessions will include simple dance steps, dynamic full body movements, muscle toning, stretching and relaxation techniques. This course is designed to prevent injury and is ideal for beginning aerobicizers, the overweight individual, injured or recuperating students, and older students as well as the general student population. This class is designed for both men and women. May be taken for credit 4 times. (UC Credit Limitation/CSU, AA GE, CSU GE)

PE 149 C Swim for Fitness .5 to 1 Units

Prerequisite: Demonstrate ability to swim.

Term hours: 24–54 hours activity depending on units attempted. This course will emphasize swimming for health and physical fitness. The class is designed to decrease the risk of coronary heart disorders by increasing heart efficiency, vital lung capacity, and the knowledge of each through the use of aerobic and anaerobic conditioning. Participating adults and others seeking a fitness program may expect to improve their overall fitness level through aquatic training. May be taken for credit 4 times. (UC Credit Limitation/CSU, AA GE, CSU GE)

PE 150 C Rhythmic Aerobic Exercise .5 to 1 Units

Term hours: 24–54 hours activity depending on units attempted. This course provides an aerobic development through rhythmic, high impact movements. The class activities will emphasize stretching, walking, jogging, running, and rope jumping in a dance setting to music. May be taken for credit 4 times. (UC Credit Limitation/CSU, AA GE, CSU GE)

PE 151 C Water Aerobics/Pool Exercises .5 to 1 Units

Term hours: 24–54 hours activity depending on units attempted. This class is designed to provide callisthenic type exercises and routines using the resistance of the water as a means for developing cardiovascular endurance, strength, flexibility, and coordination. Students will be able to improve posture and appearance through performance and understanding of using the water as a resistance. Non-swimmers welcome. May be taken for credit 4 times. (UC Credit Limitation/CSU, AA GE, CSU GE)

PE 152 C Fitness Training Lab .5 to 2 Units

Term hours: 24–108 hours activity depending on units attempted. This course is designed so that workouts can be scheduled any time the lab is open on an individual basis. Circuit training has proven especially beneficial for people not interested in competitive weight training but desiring good muscle tone and cardiovascular fitness. This type of training gives maximum return in a controlled workout with flexible hours and variable units. May be taken for credit 4 times. (UC Credit Limitation/CSU, AA GE, CSU GE)

PE 153 C Spinning .5 to 1 Units

Term hours: 24–54 hours activity depending on units attempted. Spinning is a unique, indoor, group stationary cycling program. This efficient, high-energy group exercise integrates music and cycling in a complete exercise routine. Spinning accommodates everyone's individual needs and abilities. May be taken for credit 4 times. (UC Credit Limitation/CSU, AA GE, CSU GE)

PE 154 C Fitness Testing W/Prescription 2 Units

Prerequisite: Physician's clearance required for persons age 35 or over.

Term hours: 16–18 lecture and 48–54 hours activity. This course will evaluate the fitness level of individuals by modern scientific equipment. Based on the results of a battery of tests, an exercise prescription will be developed to meet individual goals. Student progress will be evaluated with post-testing. May be taken for credit 4 times. (CSU, AA GE, CSU GE)

PE 156 C Power Training .5 to 2 Units

Term hours: 24–108 hours activity depending on units attempted. This course is an open laboratory experience for those people who want to get maximal physical return for a limited time invested. This class is designed to provide instruction and supervision of students with individualized power training programs using free weights. It is for men and women of all ages who are interested in improving power moves using squats, dead lifts, and the bench press. Workout times are adjusted to the individual's schedule with flexible hours and variable units. May be taken for credit 4 times. (UC Credit Limitation/CSU, AA GE, CSU GE)

PE 157 C Specialized Golf Skills .5 to 1 Units

Term hours: 24–54 hours activity depending on units attempted. This course will emphasize advanced golf techniques and playing strategies. The class will provide advanced and low handicap golfers the opportunity to enhance their skills and techniques in execution of golf scoring strategies. Facility use fee required. To be paid throughout the semester at the facility. May be taken for credit 4 times. (UC Credit Limitation/CSU, AA GE, CSU GE)

PE 159 C Strength Training .5 to 2 Units

Term hours: 24–108 hours activity depending on units attempted. This course is an open laboratory experience for those people who want to get maximal physical return for a limited time invested. The class is designed to provide instruction and supervision of students with individualized strength training programs using Life Fitness, Universal and Olympic weights. It is for men and women of all ages who are interested in muscle toning, muscle rehabilitation, and/or weight redistribution. Workout times are adjusted to the individual's schedule with flexible hours and variable units. May be taken for credit 4 times. (UC Credit Limitation/CSU, AA GE, CSU GE)

**ACTIVITIES DESIGNED FOR,
BUT NOT LIMITED TO, WOMEN****PE 160 C Basketball .5 to 1 Units**

Term hours: 24–54 hours activity depending on units attempted. This activity class stresses development of the fundamental skills of basketball. Game strategies including various offenses and defenses will be analyzed and applied through team competition. May be taken for credit 4 times. (UC Credit Limitation/CSU, AA GE, CSU GE)

PE 161 C Body Conditioning/Fitness .5 to 1 Units

Term hours: 24–54 hours activity depending on units attempted. This course is designed for students to participate in a comprehensive fitness program which includes stretching, cardiovascular, and strengthening exercises. The exercises help develop agility, improve coordination, and increase endurance while normalizing body weight and improving muscle tone. May be taken for credit 4 times. (UC Credit Limitation/CSU, AA GE, CSU GE)

PE 162 C Conditioning for Athletes .5 to 1 Units

Term hours: 24–54 hours activity depending on units attempted. This course is designed for individualized instruction and practice in the areas of weight training, weight lifting, anaerobic and aerobic fitness, and flexibility for competition in various intercollegiate sports. May be taken for credit 4 times. (UC Credit Limitation/CSU, AA GE, CSU GE)

PE 163 C Kick-Boxing .5 to 1 Units

Term hours: 24–54 hours activity depending on units attempted. Instruction in forms of kick-boxing that stress cardiovascular endurance, strength development, and improved flexibility. The aerobic workout will include influences from several martial arts. The sparring and self defense aspects of kick-boxing will be included. May be taken for credit 4 times. (UC Credit Limitation/CSU, AA GE, CSU GE)

PE 170 C Self Defense .5 to 1 Units

Term hours: 24–54 hours activity depending on units attempted. This course provides instruction in developing both physical and cognitive skills in personal safety and self-protection. Through different forms of martial arts training, students will practice both defensive and offensive moves against various forms of attacks, including weapons. Proficiency in the practical, effective, and tactical use of movement, leverage, strikes, and use of everyday objects as weapons is stressed. May be taken for credit 4 times. (UC Credit Limitation/CSU, AA GE, CSU GE)

PE 171 C Soccer .5 to 1 Units

Term hours: 24–54 hours activity depending on units attempted. This class will provide instruction and practice in the techniques of soccer for women. This course will develop skills, knowledge of rules, analysis of techniques and game strategies. May be taken for credit 4 times. (UC Credit Limitation/CSU, AA GE, CSU GE)

PE 172 C Softball .5 to 1 Units

Term hours: 24–54 hours activity depending on units attempted. The course will emphasize basic skills of women's softball including techniques, strategies of offense and defense, rules and terminology. May be taken for credit 4 times. (UC Credit Limitation/CSU, AA GE, CSU GE)

PE 174 C Inline Skating .5 to 1 Units

Term hours: 24–54 hours activity depending on units attempted. The course will place emphasis on inline skating fundamentals including turning, stopping, skating posture and balance. The course of study will also include terminology, etiquette and aerobic and anaerobic fitness training. Rental fee is required if the student does not supply his/her own skates and safety equipment such as helmet, wrist, elbow and knee pads. May be taken for credit 4 times. (UC Credit Limitation/CSU, AA GE, CSU GE)

PE 177 C Song and Yell Leader Workshop 1 Unit

Prerequisite: Audition.

Term hours: 48–54 lecture. This course is designed to enhance skill and difficulty level of exercises, routines, gymnastics and stunting abilities. Emphasis on leadership techniques will also be discussed. May be taken for credit 4 times. (CSU, AA GE, CSU GE)

PE 178 C Core Strength and Stability .5 to 1 Units

Term hours: 24–54 hours activity depending on units attempted. This course is designed for students to participate in a comprehensive fitness program which includes stretching and core strengthening exercises using stability balls, hand weights and tubing. The exercises help develop agility, improve coordination, and increase core body strength. May be taken for credit 4 times. (UC Credit Limitation/CSU, AA GE, CSU GE)

PE 179 C Pep Squad Training 2 Units

Prerequisite: Audition.

Term hours: 160–180 hours activity depending on units attempted. This course is designed for pep squad to develop skills in tumbling, stunts, dance technique, choreography, leadership skills, crowd motivation, and competition. Performance is mandatory at school athletic events and campus functions. May be taken for credit 4 times. (CSU, AA GE, CSU GE)

ACTIVITIES DESIGNED FOR, BUT NOT LIMITED TO, MEN**PE 180 C Baseball .5 to 1 Units**

Term hours: 24–54 hours activity depending on units attempted. The class includes instruction in the fundamental skills of baseball with emphasis on techniques, game strategy, and the correct methods to play the game. The course includes drills and class competition. May be taken for credit 4 times. (UC Credit Limitation/CSU, AA GE, CSU GE)

PE 181 C Basketball .5 to 1 Units

Term hours: 24–54 hours activity depending on units attempted. This course will include instruction in the fundamental skills of basketball with an emphasis on strategy and team play. The class will include rules, drills, and team competition. Equipment is furnished. May be taken for credit 4 times. (UC Credit Limitation/CSU, AA GE, CSU GE)

PE 182 C Body Building and Development .5 to 1 Units

Term hours: 24–54 hours activity depending on units attempted. This course includes building and developing the body through the use of progressive resistance exercises, as well as instruction in the proper techniques of power lifting. May be taken for credit 4 times. (UC Credit Limitation/CSU, AA GE, CSU GE)

PE 184 C Dodgeball .5 to 1 Units

Term hours: 24–54 hours activity depending on units attempted. The class will provide instruction and practice in the techniques of dodgeball. This course will develop skills, provide knowledge of the rules, teach students to analyze techniques, solve tactical problems and improve physical fitness. Teamwork and strategies will be emphasized while participating in several varieties of dodgeball. May be taken for credit 4 times. (UC Credit Limitation/CSU, AA GE, CSU GE)

PE 187 C Physical Fitness .5 to 1 Units

Term hours: 24–54 hours activity depending on units attempted. This course emphasizes physical fitness for men which will be achieved through the use of resistance exercises and body building routines. May be taken for credit 4 times. (UC Credit Limitation/CSU, AA GE, CSU GE)

PE 189 C Soccer .5 to 1 Units

Term hours: 24–54 hours activity depending on units attempted. This class will provide instruction and practice in the techniques of soccer for men. This course will develop skills, knowledge of rules, analysis of techniques and game strategies. May be taken for credit 4 times. (UC Credit Limitation/CSU, AA GE, CSU GE)

PE 190 C Softball .5 to 1 Units

Term hours: 24–54 hours activity depending on units attempted. The course will emphasize basic skills of softball including techniques and strategies of offense and defense, rules and terminology. May be taken for credit 4 times. (UC Credit Limitation/CSU, AA GE, CSU GE)

PE 193 C Weight Training/Weight Lifting .5 to 1 Units

Term hours: 24–54 hours activity depending on units attempted. This weight training class stresses techniques of lifting that will produce muscle tone and strength. May be taken for credit 4 times. (UC Credit Limitation/CSU, AA GE, CSU GE)

PE 194 C Wrestling .5 to 1 Units

Term hours: 24–54 hours activity depending on units attempted. This course will include instruction in the fundamental skills and knowledge necessary for successful participation in amateur wrestling. The class will develop endurance, flexibility and strength. May be taken for credit 4 times. (UC Credit Limitation/CSU, AA GE, CSU GE)

PE 197 C Recreational Football .5 to 1 Units

Term hours: 24–54 hours activity depending on units attempted. This course will include the basic fundamentals of flag and touch football. The class will emphasize rules, safety procedures, and team play. May be taken for credit 4 times. (UC Credit Limitation/CSU, AA GE, CSU GE)

PE 213 C Tennis — Men 2 Units

Prerequisite: Must meet the California Community College Commission on Athletics eligibility requirements and pass a physical examination prior to intercollegiate competition.

Term hours: 175 activity. In order to participate in intercollegiate athletics, all students must enroll in one of the above classes. The most qualified student athletes will be selected to represent the college during the season. These classes satisfy the physical education graduation requirement. These sports will stress fundamentals, team/individual play, and mental and physical conditioning. Daily practice or a minimum of ten hours per week is required. May be taken for credit 3 times. (UC Credit Limitation/CSU, AA GE, CSU GE)

PE 214 C Tennis — Women 2 Units

Prerequisite: Must meet the California Community College Commission on Athletics eligibility requirements and pass a physical examination prior to intercollegiate competition.

Term hours: 175 activity. In order to participate in intercollegiate athletics, all students must enroll in one of the above classes. The most qualified student athletes will be selected to represent the college during the season. These classes satisfy the physical education graduation requirement. These sports will stress fundamentals, team/individual play, and mental and physical conditioning. Daily practice or a minimum of ten hours per week is required. May be taken for credit 3 times. (UC Credit Limitation/CSU, AA GE, CSU GE)

PE 218 C Volleyball — Women 2 Units

Prerequisite: Must meet the California Community College Commission on Athletics eligibility requirements and pass a physical examination prior to intercollegiate competition.

Term hours: 175 activity. In order to participate in intercollegiate athletics, all students must enroll in one of the above classes. The most qualified student athletes will be selected to represent the college during the season. These classes satisfy the physical education graduation requirement. These sports will stress fundamentals, team/individual play, and mental and physical conditioning. Daily practice or a minimum of ten hours per week is required. May be taken for credit 3 times. (UC Credit Limitation/CSU, AA GE, CSU GE)

PE 219 C Water Polo 2 Units

Prerequisite: Must meet the California Community College Commission on Athletics eligibility requirements and pass a physical examination prior to intercollegiate competition.

Term hours: 175 activity. In order to participate in intercollegiate athletics, all students must enroll in one of the above classes. The most qualified student athletes will be selected to represent the college during the season. These classes satisfy the physical education graduation requirement. These sports will stress fundamentals, team/individual play, and mental and physical conditioning. Daily practice or a minimum of ten hours per week is required. May be taken for credit 3 times. (UC Credit Limitation/CSU, AA GE, CSU GE)

PE 220 C Wheelchair Basketball 2 Units

Prerequisite: Must meet the California Community College Commission on Athletics eligibility requirements and pass a physical examination prior to intercollegiate competition.

Term hours: 175 activity. In order to participate in intercollegiate athletics, all students must enroll in one of the above classes. The most qualified student athletes will be selected to represent the college during the season. These classes satisfy the physical education graduation requirement. These sports will stress fundamentals, team/individual play, and mental and physical conditioning. Daily practice or a minimum of ten hours per week is required. May be taken for credit 4 times. (UC Credit Limitation/CSU, AA GE, CSU GE)

PE 222 C Badminton — Women 2 Units

Prerequisite: Must meet the California Community College Commission on Athletics eligibility requirements and pass a physical examination prior to intercollegiate competition.

Term hours: 175 activity. In order to participate in intercollegiate athletics, all students must enroll in one of the above classes. The most qualified student athletes will be selected to represent the college during the season. These classes satisfy the physical education graduation requirement. These sports will stress fundamentals, team/individual play, and mental and physical conditioning. Daily practice or a minimum of ten hours per week is required. May be taken for credit 3 times. (UC Credit Limitation/CSU, AA GE, CSU GE)

THEORY — PHYSICAL EDUCATION**PE 231 C Elementary School Movement — P E 3 Units**

Term hours: 32–36 lecture and 32–36 laboratory. This course is designed to acquaint the prospective elementary school teachers with physical education programs in grades K-6. The course includes observation, visitation, and actual teaching field work at an elementary school. The campus laboratory hours include methods, skills, and activities used in teaching elementary physical education. The class is recommended for elementary education majors and recommended for recreation and physical education majors. (CSU, CSU GE)

PE 234 C Contemporary Personal Health 3 Units

Term hours: 48–54 lecture. The course explores advances in the medical science field as they relate to personal health and dispels myths and misconceptions. Health issues that will be covered in the course are stress management, substance abuse, alcoholism, smoking as an addiction, sexuality, marriage, birth, sexually transmitted diseases, nutrition, cancer, aging and death, and obesity. Credit by Examination. (UC/CSU, AA GE, CSU GE)

PE 235 C First Aid, CPR and Emergencies 3 Units

Term hours: 48–54 lecture. This course includes the theory and implementation of the skills necessary in response to an emergency. Successful completion of the course will qualify the student for the American Red Cross "Responding to Emergencies" First Aid Certificate, Adult, Child and Infant CPR Certificates and Automated External Defibrillation Certificate. Costs may include materials for the construction of a First Aid Kit. There is a required \$14.00 Red Cross Service Fee — Payable at Registration. (UC/CSU, CSU GE)

PE 236 C Prevention and Care/Athletic Injuries 3 Units

Term hours: 32–36 lecture and 48–54 laboratory. This course is designed for future athletic trainers, coaches, and physical therapists in the field of sports medicine. The course concentrates on the prevention, evaluation, treatment and rehabilitation of athletic injuries. Methods of taping and the use of training room equipment will also be covered. (UC/CSU)

PE 237 C Lifesaving 1 Unit

Prerequisite: A minimum of 15 years of age, the ability to swim continuously 500 yards and complete a 7 to 10 feet surface dive.

Term hours: 16–18 lecture and 16–18 laboratory. This course is designed to develop and perfect the basic swimming strokes needed to successfully execute the various lifesaving skills. Upon completion of the class, a student who successfully passes the written and practical exams will be qualified to be certified for an American Red Cross Lifeguard Training, First Aid, and CPR for the Professional Rescuer. May be taken for credit 4 times. \$18.00 Material Fee — Payable at Registration. (UC/CSU, CSU GE)

PE 238 C Water Safety Instruction 2 Units

Prerequisite: 17 years of age minimum, American Red Cross precourse written and skills test.

Advisory: Competency in swimming, diving, and water safety skills.

Term hours: 16–18 lecture and 32–36 hours activity. This American Red Cross course will prepare instructor candidates to teach a variety of American Red Cross swimming and water safety courses to people of all ages. Upon satisfactory completion, the student will receive an American Red Cross Water Safety Instructor certificate. This class does not meet the requirements for P.E. activity classes. \$5.00 Material Fee — Payable at Registration. (UC/CSU)

PE 239 C Skin and Scuba Diving 3 Units

Prerequisite: Qualification as an intermediate/advanced swimmer.

Term hours: 32–36 lecture and 48–54 hours activity. This course is designed to develop the knowledge of skin and SCUBA diving. The class will place emphasis on safety, skill development, psychological adjustments and cardiovascular conditioning. Upon successful completion of the class, the student will be certified as an N.A.U.I., Open Water I, SCUBA diver. The student is responsible for equipment rentals and boat fees, as well as purchasing some basic personal gear. This class does not meet the requirement for P.E. activity classes. (UC Credit Limitation/CSU)

PE 240 C Sports Officiating 3 Units

Term hours: 32–36 lecture and 32–36 hours activity. This class provides practical experience with an emphasis on knowledge and interpretation of the rules of sporting events. The rules and mechanics of officiating basketball, baseball, softball, volleyball and other sports will be covered. This course can be used for recreation majors, physical education majors, and people involved in community athletic organizations. The course will also explore avenues of employment related to sports officiating. May be taken for credit 2 times. (UC/CSU)

PE 242 C Wheelchair Athletics 2 Units

Prerequisite: Entry into this class will be based on the student's previous medical history.

Term hours: 16–18 lecture and 48–54 laboratory. The course includes instruction and participation in the fundamentals of the spectrum of wheelchair athletics. The course is expressly designed for, but not limited to, those students with permanent disability of the lower extremities who are therefore unable to participate in regular able-bodied athletics. The emphasis is on rules, safety, general awareness of wheelchair athletic alternatives with specific skill development in wheelchair basketball and wheelchair tennis leading to competition in California and U.S. wheelchair basketball and tennis programs. May be taken for credit 4 times. (UC Credit Limitation/CSU)

PE 244 C Human Performance 3 Units

Term hours: 48–54 lecture. This course provides guidelines for lifetime fitness with a combined approach of exercise physiology, nutrition and biomechanics. Students will develop a working knowledge of physiological adaptations to aerobic and anaerobic exercise, of nutritional programs to achieve and maintain ideal body weight, and of desirable lifestyle management behaviors to improve wellness and human performance. (UC/CSU, AA GE, CSU GE)

PE 247 C Sports Management 3 Units

Term hours: 32–36 lecture and 48–54 hours activity. This course consists of how to organize, manage, plan, staff, direct and control a sports program. The course also includes such areas as budget, facilities, scheduling, officials, transportation, public relations, parent and booster clubs, purchase and care of athletic equipment, fund-raising, and marketing. (CSU)

PE 248 C Psychology of Sport 3 Units

Term hours: 48–54 lecture. This course consists of the psychological study of athletics on all levels of competition. The course includes such areas as competition, understanding coaches, goal setting, motivation, youth sports, anxiety and stress, relaxation and sport imagery, relationships, and drug abuse in sports. (CSU)

PE 250 C Sport and United States Society 3 Units

Term hours: 48–54 lecture. This course examines sport in the United States society and how various ethnic and under-represented groups have influenced sport participation at the local, state, and national levels. Influences of other cultures outside of the United States will be reviewed and analyzed. Media influences on the perception of sport in society will be examined. (CSU, CUL DIV)

PE 252 C Introduction to Kinesiology 3 Units

Term hours: 48–54 lecture. Introduction and orientation to the field of kinesiology as a profession and as an academic discipline. Explores subdisciplines, opportunities in the field, philosophy, and scientific foundation. (UC/CSU)

PE 261 C Pro Activities: Tennis 2 Units

Term hours: 16–18 lecture and 32–36 hours activity. This course is designed for physical education and recreation majors. The course will include a comprehensive analysis of the principles of movement, motor skills and the strategy concepts used in tennis. Students will be responsible for performing and teaching various skills. Students must provide their own equipment. May be taken for credit 2 times. (UC Credit Limitation/CSU)

PE 262 C Pro Activities: Volleyball — Coed 2 Units

Term hours: 16–18 lecture and 32–36 hours activity. This course is designed for men and women physical education and recreation majors. This class will emphasize development and improvement of fundamental volleyball skills. Course content will include strategy and team organization through participation, analysis of rules, instructional procedures and coaching techniques. May be taken for credit 2 times. (UC Credit Limitation/CSU)

PE 263 C Pro Activities: Wrestling 2 Units

Term hours: 16–18 lecture and 32–36 hours activity. This course will include instruction and practice in the fundamental wrestling techniques basic to successful performance in amateur wrestling. The class will include all aspects of offense, defense and additional areas such as equipment, budget, scheduling, and scouting. May be taken for credit 2 times. (UC Credit Limitation/CSU)

PE 265 C Intramural Management 2 Units

Term hours: 16–18 lecture and 48–54 laboratory. This course will emphasize effective management skills for an intramural program. The class will include group organization, promotion and supervision of campus intramural activities. May be taken for credit 4 times. (CSU)

PE 266 C Theory of Coaching Basketball 3 Units

Term hours: 32–36 lecture and 48–54 laboratory. This course is designed to study the various aspects of coaching basketball. The emphasis of the class will be on the theory of how to organize a basketball program activity from start to finish of a season. The development of individual/team skills both offensive and defensive will be examined. The lab consists of scouting and/or coaching basketball. (UC Credit Limitation/CSU)

PE 267 C Theory of Coaching Baseball**3 Units**

Term hours: 32–36 lecture and 48–54 hours activity. This course includes the study of various aspects of coaching baseball. The emphasis of the class will be on the theory of how to organize a baseball program, develop individual skills, and coach offensive and defensive teamwork. The lab consists of scouting and coaching baseball. (UC Credit Limitation/CSU)

PE 280 C Professional Activities: Baseball**2 Units**

Term hours: 16–18 lecture and 32–36 hours activity. This course is designed to emphasize the learning of skills and fundamentals of the game of baseball. The class will include activities that will develop the psychological as well as the physical preparation of a baseball player. The theory and practical experiences related to offensive and defensive phases of the game will also be covered. May be taken for credit 2 times. (UC Credit Limitation/CSU)

PE 281 C Pro Activities: Basketball**2 Units**

Term hours: 16–18 lecture and 32–36 hours activity. This course is designed for physical education and recreation majors. The course will include a comprehensive analysis of the principles of movement, motor skills, and the strategy concepts used in basketball. May be taken for credit 2 times. (UC Credit Limitation/CSU)

PE 282 C Pro Activities: Softball**2 Units**

Term hours: 16–18 lecture and 32–36 hours activity. This course is designed for physical education and recreation majors. The course will emphasize development and improvement of fundamental skills, including strategy, team organization, rules and instructional procedures. May be taken for credit 2 times. (UC Credit Limitation/CSU)

PE 284 C Pro Activities: Soccer**2 Units**

This course is designed for physical education majors. The course will include a comprehensive analysis of fundamental skills, game strategy, team offense and team defense through participation, analysis of rules and instructional procedures. May be taken for credit 2 times. (UC Credit Limitation/CSU)

PE 286 C Pro Activities: Weight Training**2 Units**

Term hours: 16–18 lecture and 32–36 hours activity. This course is a study of weight training theory with emphasis on kinesiology and biomechanical principles. The class will provide the student with an understanding of various anaerobic training techniques and their applications. May be taken for credit 2 times. (UC Credit Limitation/CSU)

PE 298 C PE Seminar**.5 to 12 Units**

Prerequisite: May be required.

Corequisite: May be required.

Advisory: May be required.

Term hours: 0–216 lecture and/or 0–1080 laboratory depending on units attempted. This class will utilize a lecture/lab activity approach to various topics in physical education. A variety of classes will be offered in order to introduce able bodied students to new experiences in physical education. Fees may be required — Payable at Registration. May be taken for credit 1–4 times. Pass/No Pass or Pass/No Pass/Letter Grade Option or Standard Letter Grade. (UC Credit Limitation/CSU)

PE 299 C Physical Education — Independent Study**.5 to 2 Units**

Prerequisite: Approved Independent Study Learning Contract.

Term hours: A maximum of 108 hours depending on units attempted. This course is designed for students who wish to gain experience in teaching physical education classes or to increase their knowledge and experience in applied areas (coaching and teaching). Students must obtain permission from the instructor in the subject area they will be working with, and will be under the direct supervision of that instructor. This course does not meet requirements of physical education activity classes. May be taken for credit 4 times. (UC Credit Limitation/CSU)

Physical Science

Division of Science/Engineering/Mathematics

Division Dean — Richard Fee

Faculty

Ron Armale

Michael Frey

Brinda Subramaniam

Counselor

Deidre Porter

Physical Science (PHSC)

PHSC 104 C Physical Science for Teachers**4 Units**

Same as CHEM 104 C.

Prerequisite: MATH 020 C with a minimum grade of "C."

Term hours: 48–54 lecture and 48–54 laboratory. This activity-based course provides an introduction to the basic concepts of physical science with emphasis on their practical importance and application in the real world. Topics include global warming, the automobile, health, and energy. This course is intended for students who want to become primary school teachers. Duplicate credit not granted for CHEM 104 C. (CSU, AA GE, CSU GE)

PHSC 117 C Cosmology**1 Unit**

Prerequisite: ASTR 116 C or PHSC 101 C.

Term hours: 16–18 lecture. The course includes a study of black holes, galactic evolution, methods and assumptions of cosmology, the big bang, geometry and models, the inflationary universe, anthropic principle, destiny of the universe, particle theory, and grand unification. (CSU)

PHSC 196 C Field Studies in Physical Science**2 Units**

Term hours: 16–18 lecture and 48–54 laboratory. This course involves lecture and field study in the physical sciences. During a given semester, multiple sections may be offered to different study areas or for different selected topics. Study areas include, but are not limited to, star gazing in the Santa Ana mountains or Anza area; viewing museums, planetarium, observatories; or listening to lectures. Field trips are required. May be taken for credit 4 times. (CSU)

PHSC 298 C Physical Science Seminar .5 to 12 Units*Prerequisite: May be required.**Corequisite: May be required.**Advisory: May be required.*

Term hours: 0–216 lecture and/or 0–648 laboratory depending on units attempted. This course is for students who wish to increase their knowledge in various fields in the physical sciences. Various topics may be offered, such as the metric system of measurement, observational astronomy, etc., according to the interests of the instructor and students as stated in the class schedule. Consult the class schedule to verify unit credit and topics for a particular semester. Fees may be required — Payable at Registration. May be taken for credit 1–4 times. Pass/No Pass or Pass/No Pass/Letter Grade Option or Standard Letter Grade. (UC Credit Limitation/CSU)

PHSC 299 C Physical Sciences Independent Study .5 to 2 Units*Prerequisite: Approved Independent Study Learning Contract.*

Term hours: 48–54 laboratory or project research for maximum credit. This course is for able students who have demonstrated interest and capability for increased knowledge of physical science through individual study, small group discussion conferences, or special laboratory project work. Independent laboratory or field study projects with staff supervision may be approved with written reports required. May be taken for credit 4 times. (UC Credit Limitation/CSU)

Physical Therapy

PHYSICAL THERAPY TRANSFER PROGRAM

Professional programs such as dentistry, medicine, pharmacy, optometry, physician assistant, physical therapy and veterinary medicine are most often graduate programs that require a bachelor degree or significant preparation prior to entering the program. The appropriate preparation varies according to the school and specific program. Students are advised to meet with a counselor to discuss options for their bachelor degree and the lower division requirements for the program and school of their choice.

Physician Assistant

PHYSICIAN ASSISTANT TRANSFER PROGRAM

Professional programs such as dentistry, medicine, pharmacy, optometry, physician assistant, physical therapy and veterinary medicine are most often graduate programs that require a bachelor degree or significant preparation prior to entering the program. The appropriate preparation varies according to the school and specific program. Students are advised to meet with a counselor to discuss options for their bachelor degree and the lower division requirements for the program and school of their choice.

Physics

Division of Science/Engineering/Mathematics*Division Dean* — Richard Fee*Faculty*

Ron Armale
Michael Frey
Brinda Subramaniam

Counselor

Deidre Porter

PROGRAM LEARNING OUTCOMES (PLOs)

The courses taught by this department contribute to the General Education and Basic Skills Program Learning Outcomes. Please refer to General Education and Basic Skills Program Learning Outcomes.

PHYSICS TRANSFER PROGRAM

Students should consult a counselor or www.assist.org for lower division major requirements for most California public universities. (See the Standard Definitions section of the catalog for a description of ASSIST.) Students transferring to an independent college/university should consult the catalog of the individual school and a counselor for lower division major requirements.

Physics (PHYS)

PHYS 021 C Problem Solving — Mechanics 1 Unit*Advisory: Students are recommended to be enrolled in PHYS 201 C or PHYS 210 C.*

Term hours: 16–18 lecture. This course is designed as a problem solving session and examination of the concepts in classical mechanics as taught in the first semester of College Physics (PHYS 201 C) or Physics (PHYS 210 C). Non-Degree Credit. Pass/No Pass only.

PHYS 022 C Problem Solving — Electricity 1 Unit*Advisory: Students are recommended to be enrolled in PHYS 202 C or PHYS 211 C.*

Term hours: 16–18 lecture. This course is designed as a problem solving session and examination of the concepts in electricity, magnetism, and optics as taught in the second semester of College Physics (PHYS 202 C) or Physics (PHYS 211 C). Non-Degree Credit. Pass/No Pass only.

PHYS 023 C Phys 221 C Problem Solving 1 Unit*Corequisite: PHYS 221 C General Physics.*

Term hours: 16–18 lecture. This course is designed as a problem solving session and examination of the concepts in classical mechanics as taught in the first semester of General Physics (PHYS 221 C). Non-Degree Credit. Pass/No Pass only.

PHYS 024 C Phys 222 C Problem Solving 1 Unit*Corequisite: PHYS 222 C General Physics.*

Term hours: 16–18 lecture. This course is designed as a problem solving session and examination of the concepts in electricity and electromagnetism optics as taught in the second semester of General Physics (PHYS 222 C). Non-Degree Credit. Pass/No Pass only.

PHYS 130 C Elementary Physics 4 Units*Prerequisite: MATH 020 C with a grade of "C" or better.*

Term hours: 48–54 lecture and 48–54 laboratory. This is an entry level physics course for all science majors. The course provides an introduction to the basic concepts and laws of physics with emphasis upon their practical importance in everyday life. Laboratory work includes experiments in mechanics, heat, sound, electricity, and optics. This is a general education course in the physical science area. The course is not open for credit to students with previous college physics credit. No UC credit if taken after PHYS 201 C or PHYS 221 C. (UC Credit Limitation/CSU, AA GE, CSU GE, IGETC)

PHYS 201 C College Physics I 4 Units*Prerequisite: MATH 142 C and PHYS 130 C, with grades of "C" or better.*

Term hours: 48–54 lecture and 48–54 laboratory. This is the first half of an algebra based two-semester physics sequence (PHYS 201 C and PHYS 202 C) designed primarily for students planning to major in life sciences, medical/dental fields, architecture, psychology, and similar professional fields. The course covers Newtonian mechanics, conservation laws, rotational dynamics, properties of matter, heat, and waves. The laboratory portion of the course investigates these topics both qualitatively and quantitatively, and includes the use of graphing, statistics, and propagation of errors. This course satisfies a requirement for biology majors in the CSU system, but not the UC system. (UC Credit Limitation/CSU, AA GE, CSU GE, IGETC)

PHYS 202 C College Physics II 4 Units*Prerequisite: PHYS 201 C, with a grade of "C" or better.*

Term hours: 48–54 lecture and 48–54 laboratory. This is the second half of an algebra-based two-semester sequence (PHYS 201 C and 202 C) designed primarily for students planning to major in life sciences, medical/dental fields, architecture, psychology, and similar professional fields. This course covers electricity and magnetism, optics, atomic physics, nuclear physics, and special theory of relativity. The laboratory portion of the course investigates these topics both qualitatively and quantitatively, and includes the use of graphing, statistics, and propagation of errors. This course satisfies a requirement for biology majors in the CSU system but not the UC system. (UC Credit Limitation/CSU, CSU GE, IGETC)

PHYS 210 C Physics for Life Sciences I 4 Units*Prerequisite: PHYS 130 C or High School Physics and MATH 150AC, with a grade of "C" or better, or concurrent enrollment in MATH 150AC.*

Term hours: 48–54 lecture and 48–54 laboratory. This is the first half of a calculus-based two-semester sequence (PHYS 210 C and 211 C) designed for students majoring in the life sciences. This course covers Newtonian mechanics, conservation laws, rotational dynamics, properties of matter, heat and waves. The laboratory portion of the course investigates these topics both qualitatively and quantitatively, and includes the use of graphing, statistics, and propagation of errors. This course satisfies a requirement for biology majors in the UC system; the CSU system will accept either this sequence or PHYS 201 C and 202 C sequence. (UC Credit Limitation/CSU, AA GE, CSU GE, IGETC)

PHYS 211 C Physics for Life Sciences II 4 Units*Prerequisite: PHYS 210 C with a grade of "C" or better and completion of or concurrent enrollment in MATH 150BC.*

Term hours: 48–54 lecture and 48–54 laboratory. This is the second half of a calculus-based two-semester sequence (PHYS 210 C and 211 C) designed for students majoring in the life sciences. This course covers electricity, magnetism, optics, special relativity, and modern physics. The laboratory portion of the course investigates these topics both qualitatively and quantitatively, and includes the use of graphing, statistics, and propagation of errors. This course satisfies a requirement for biology majors in the UC system; the CSU system will accept either this sequence or PHYS 201 C and 202 C sequence. (UC Credit Limitation/CSU, AA GE, CSU GE, IGETC)

PHYS 221 C General Physics I 4 Units

Prerequisite: PHYS 130 C with a minimum grade of "C" (or high school physics with a minimum grade of "B") and MATH 150AC, with a minimum grade of "C"; and completion of or concurrent enrollment in MATH 150BC. Term hours: 48–54 lecture and 48–54 laboratory. This is the first course of a three-semester introductory physics program for students majoring in physics, chemistry, geology, engineering (all areas), computer science, mathematics and other related fields. Topics studied include mechanics, oscillations, properties of matter, and fluids. Problems and derivations require knowledge of differential and integral calculus. (UC Credit Limitation/CSU, AA GE, CSU GE, IGETC)

PHYS 222 C General Physics II 4 Units*Prerequisite: MATH 150BC and PHYS 221 C, with grades of "C" or better.**Advisory: MATH 250AC.*

Term hours: 48–54 lecture and 48–54 laboratory. This course is part of a three-semester program of introductory calculus based physics for students majoring in physics, chemistry, geology, engineering (all specializations), computer science, mathematics and other related fields. Topics covered are basic laws of electricity and magnetism including electrostatics, current, magnetic fields, electromagnetic induction, DC circuits, AC circuits, and electromagnetic waves. Requires knowledge of differential and integral calculus. (UC Credit Limitation/CSU, CSU GE, IGETC)

PHYS 223 C General Physics III 4 Units*Prerequisite: PHYS 221 C, and MATH 150BC, with grades of "C" or better.**Advisory: Concurrent enrollment in MATH 250AC or MATH 250BC.*

Term hours: 48–54 lecture and 48–54 laboratory. This course is part of a three-semester program of introductory calculus based physics for students majoring in physics, chemistry, geology, engineering (all areas), mathematics, and other related fields. It may be taken before or after PHYS 222 C. Topics covered include fluid mechanics, oscillations and waves, thermodynamics and kinetic theory, geometrical and physical optics, special theory of relativity, introduction to quantum mechanics, atomic physics, and nuclear physics. Requires knowledge of differential and integral calculus. (UC Credit Limitation/CSU, CSU GE, IGETC)

Political Science

Division of Social Sciences

Division Dean — Nina DeMarkey*Faculty*

Gloria Badal

Eapen Peter Mathews

Counselors

Velia Lawson

Therese Mosqueda-Ponce

Daniel Pelletier

PROGRAM LEARNING OUTCOMES (PLOs)

The courses taught by this department contribute to the General Education and Basic Skills Program Learning Outcomes. Please refer to General Education and Basic Skills Program Learning Outcomes.

POLITICAL SCIENCE TRANSFER PROGRAM

Students should consult a counselor or www.assist.org for lower division major requirements for most California public universities. (See the Standard Definitions section of the catalog for a description of ASSIST.) Students transferring to an independent college/university should consult the catalog of the individual school and a counselor for lower division major requirements.

Political Science (POSC)

POSC 100 C United States Government 3 Units

Advisory: Eligibility for ENGL 100 C.

Term hours: 48–54 lecture. This course covers the political theories and practices of United States Government at national, state and local levels. Duplicate credit not granted for POSC 100HC. Credit by Examination. (UC Credit Limitation/CSU, AA GE, CSU GE, IGETC)

POSC 100HC Honors United States Government 3 Units

Advisory: Eligibility for ENGL 100 C.

Term hours: 48–54 lecture. This course is an enhanced college level course enhanced for honors students. It covers the political theories and practices of the United States Government at national, state and local level. Duplicate credit not granted for POSC 100 C. (UC Credit Limitation/CSU, AA GE, CSU GE, IGETC)

POSC 101 C Gender and American Politics 3 Units

Advisory: Eligibility for ENGL 100 C.

Term hours: 48–54 lecture. This course is an introduction to the study of American politics at the national, state, and local levels with an emphasis on the role of gender. It examines women's participation in American politics from the perspective of race, class, and ethnicity. Contemporary political analysis will focus on women's political agenda from the 1960s to the 21st century, centering around issues such as equal pay, sex discrimination in education and the work place, affirmative action, reproductive rights, sexual choice, domestic violence, and increasing the representation of women in local and national political arenas. (UC/CSU, AA GE, CSU GE, IGETC)

POSC 120 C Political Theory 3 Units

Advisory: Eligibility for ENGL 100 C.

Term hours: 48–54 lecture. This course is a survey of Western political theory from ancient Greece to the Modern Age. It shows how political theory shapes current institutions and ideologies in the United States, Europe, and other countries around the world. (UC/CSU, AA GE, CSU GE, IGETC)

POSC 130 C Political Communication 3 Units

Term hours: 48–54 lecture. This course covers the theory and application of rhetorical criticism to contemporary and political communication events. Stress will be placed on the rhetorical/political strategies used to advance concepts and policy options. (UC/CSU, CSU GE, IGETC)

POSC 135 C Campaigns, Parties and Elections 3 Units

Advisory: Eligibility for ENGL 100 C.

Term hours: 48–54 lecture. This course is an analysis of the challenges faced by the Democratic and Republican parties as they are being replaced by campaign management firms (CMF's), Political Action Committees (PAC's) and electronic media advertising. Special emphasis is given to critical analysis of the presidential election campaign process, and of the resulting implications of the democratic process in the United States. (CSU)

POSC 200 C Introduction to Political Science 3 Units

Advisory: Eligibility for ENGL 100 C.

Term hours: 48–54 lecture. This course is an introduction to the study of political science. It explores the many aspects of politics, examining its relationship to morality, culture, economics, justice and international affairs both theoretically and practically. As an introductory course, it includes elements from the major sub-disciplines of political science, including American politics, comparative politics, and international relations. (UC/CSU, AA GE, CSU GE, IGETC)

POSC 209 C Urban Politics 3 Units

Advisory: Eligibility for ENGL 100 C.

Term hours: 48–54 lecture. This course is a concentrated study of urban America with particular emphasis on the challenging problems facing the country's metropolitan areas. The approach will be interdisciplinary in order to facilitate conceptual learning and a balanced understanding of the urban dilemma. Major areas of study will include the history and development of urban United States intergovernmental relations, poverty, racial and ethnic relations, pollution, crime, public services, education, planning and renewal. (UC/CSU, CSU GE, IGETC, CUL DIV)

POSC 210 C Contemporary Political Issues 3 Units

Advisory: Eligibility for ENGL 100 C.

Term hours: 48–54 lecture. This course is an intensive study of contemporary issues associated with the concepts of democracy, federalism, separation of powers, judicial review, preservation of individual rights and related topics. (UC/CSU, AA GE, CSU GE, IGETC)

POSC 215 C Comparative Politics 3 Units

Advisory: Eligibility for ENGL 100 C.

Term hours: 48–54 lecture. This course is a comparative study of the political theories and practices of selected European and non-Western political systems. Also included in the course is a careful analysis of the dynamics of political change and its relationship to economic and social development. (UC/CSU, AA GE, CSU GE, IGETC)

POSC 216 C Politics of the Middle East 3 Units

Advisory: Eligibility for ENGL 100 C.

Term hours: 48–54 lecture. This course is an introduction to the political, social, economic and ideological foundations of Middle East in general and major states in the region in particular. Emphasis is placed on the political and economic developments in Egypt, Iraq, Iran, Israel, and Saudi Arabia. Topics covered include: introduction to the land, peoples, cultures, and religions; colonialism and the emergence of modern states following World War I; Western influence and Islamic revivalism; regional conflicts (Arab-Israeli, Iran-Iraq, Gulf Wars); and politics and economics of it; U.S. based ethnic interest groups and their influence on U.S. foreign policy; patrimonialism and militarism; liberalization and democratization. (UC/CSU, AA GE, CSU GE, IGETC)

POSC 220 C Introduction to Public Administration 3 Units

Term hours: 48–54 lecture. This course will concentrate on giving the student a background in fiscal policy (budgeting), personnel, policy-making, and general organization. (CSU)

POSC 230 C International Relations**3 Units***Advisory: Eligibility for ENGL 100 C.*

Term hours: 48–54 lecture. This course is a study of relations of nations including the function of power, diplomacy, international law and organizations, and economic factors. Special emphasis will be placed on such concepts as war, nationalism, imperialism, ideological conflict and collective security, and how these concepts affect American foreign policy. (UC/CSU, AA GE, CSU GE, IGETC)

POSC 298 C Political Science Seminar**.5 to 12 Units***Prerequisite: May be required.**Corequisite: May be required.**Advisory: May be required.*

Term hours: 0–216 lecture and/or 0–432 laboratory depending on units attempted. This is a lecture/discussion type course developed on a particular limited problem or topic of interest to students. It is designed for able students who wish to increase their knowledge of a particular topic concerning which no other regular class is offered. A paper or group activity may be requested. Credit may range from .5 units to 12 units. Consult class schedule for the offerings a particular semester. May be taken for credit 1–4 times. Pass/No Pass or Pass/No Pass/Letter Grade Option or Standard Letter Grade. Fees may be required — Payable at Registration. (UC Credit Limitation/CSU)

POSC 299 C Political Science Independent Study**1 Unit***Prerequisite: Approved Independent Study Learning Contract.*

May be taken for credit 4 times. Varying hours of scheduled conferences per week according to instructor. Independent study is for able students who wish to extend their knowledge of a particular area through individual research and study. It is thought that topics might develop out of a curiosity stimulated in a regular class. The student would then contact the supervising instructor to develop a contract for his/her particular interest so that they could learn more regarding their special topic. (UC Credit Limitation/CSU)

Portuguese

Division of Language Arts

Division Dean — Eldon Young*Faculty*

A. Fernando Oliveira

Counselors

Velia Lawson

Daniel Pelletier

Therese Mosqueda-Ponce

PROGRAM LEARNING OUTCOMES (PLOs)

The courses taught by this department contribute to the General Education and Basic Skills Program Learning Outcomes. Please refer to General Education and Basic Skills Program Learning Outcomes.

Portuguese (PORT)

PORT 101 C Elementary Portuguese I**5 Units**

Term hours: 80–90 lecture. The course focuses on the four major skills of language learning—listening comprehension, speaking, reading, and writing—and the grammar and vocabulary necessary to acquire these skills. Included is an introduction to customs, culture, and civilization of Brazil, Portugal and other Portuguese-speaking countries. Pass/No Pass/Letter Grade Option. (UC/CSU, AA GE, CSU GE)

PORT 102 C Elementary Portuguese II**5 Units***Prerequisite: PORT 101 C Elementary Portuguese I with a grade of “C” or better or one year of high school Portuguese with a grade of “C” or better.*

Term hours: 80–90 lecture. This course continues to emphasize the acquisition of basic skills in pronunciation, listening, speaking, reading, and writing. Students will increase their knowledge of the culture, history, and geography of Portuguese speaking countries through lectures, slides, films, and reading and writing assignments. Pass/No Pass/Letter Grade Option. (UC/CSU, AA GE, CSU GE, IGETC)

Pre-Professional Programs

Dentistry**Medicine****Optometry****Pharmacy****Physician Assistant****Physical Therapy****Veterinary Medicine**

Professional programs such as dentistry, medicine, pharmacy, optometry, physician assistant, physical therapy and veterinary medicine are most often graduate programs that require a bachelor degree or significant preparation prior to entering the program. The appropriate preparation varies according to the school and specific program. Students are advised to meet with a counselor to discuss options for their bachelor degree and the lower division requirements for the program and school of their choice.

Psychiatric Technology

Division of Health Science

Division Dean — John Sciacca

Faculty

Jeannie Blilie

Jane Boyce

Joseph Franks

Christina Johannsen

Marcus Marquardt

Jaime Ramos

Noemi Rios

Counselors

Kelly Carter

Denise Vo

PROGRAM LEARNING OUTCOMES (PLOs)

Psychiatric Technology

A student who completes the Psychiatric Technology program will be able to:

1. Show effective communication with the patient/client, family, health care team, and community.
2. Identify and prioritize nursing diagnoses through assessment/observation of the patient/client's physical condition, behavior and through interpretation/analysis of information obtained from the patient, client record and others, including members of the health care team.
3. Create a plan of care in collaboration with the patient/client which ensures that direct and indirect nursing, psychiatric care and habilitation training provided for the patient/client's safety, comfort, hygiene, and protection, as well as disease prevention, health promotion, and restorative measures.
4. Perform skills essential to implement safe and effective care to individuals with nursing needs, psychiatric disorders and/or developmental disabilities that involve explaining health treatment, and the teaching patient/client and family how to meet his or her health care needs.
5. Evaluate the expected outcomes of the plan of care through observation of the client's physical condition, behavior, signs and symptoms of illness, reactions to treatment, and through communication with the patient/client and the health care team members; modifies/progresses plan as needed.
6. Advocate for the patient/client by initiating action to improve health care and to make informed decisions.
7. Practice according to ethical and legal professional standards as set forth by the Cypress College Psychiatric Technician program and the California Board of Vocational Nursing and Psychiatric Technicians.
8. Evaluate personal strengths and growth needs and incorporate these into a plan for professional development.

PROGRAM OBJECTIVES

This program aims to prepare a student to meet the requirements for licensure as a Psychiatric Technician in the state of California. A Psychiatric Technician is a licensed member of the professional healthcare services team working with people who are emotionally or developmentally disabled. Employed by private and state mental hospitals, developmental centers, and many community facilities. Psychiatric Technicians will also find a variety of jobs available in the fields of prisons/corrections and human services. These include substance abuse programs, forensic facilities, special education and many other areas promoting mental health. There are career advancement opportunities available in the areas of counseling, education, nursing, and vendorization of services.

The program is *accredited* by, and *conforms* to, the regulations of the California Board of Vocational Nursing and Psychiatric Technicians. Upon successful completion of the program, graduates are eligible to take the State Board Licensure Examination.

MINIMUM STANDARDS FOR APPLICANTS

1. Graduation from high school or completion of the General Education Development (GED) test with an average score of 450 on the five-test battery or passing the high school proficiency examination. Possession of an associate or higher degree satisfies this requirement.
2. Completion of ENGL 058 C/ESL 185 C or a comparable course with a grade of "C" or better, or submission of test scores that indicate eligibility for ENGL 060 C/ESL 186 C.
3. Completion of BIOL 160 C and PSY 101 C with a "C" or better or transcript showing courses in progress.

APPLICATION PROCEDURES

1. Meet with a counselor to determine fulfillment of the minimum standards.
2. Applications must be completed **online**. Please see the **Health Science Application link** on the Psychiatric Technology home page.
3. Submit supporting documentation with the signature page of application. This includes a copy of high school diploma, GED or high school proficiency and **official** college transcripts.

SELECTION CRITERIA

1. Twenty-four (24) students are selected for admission each Fall and Spring semester. The number of applicants usually exceeds available seats.
2. Selection is based on completion of required prerequisites and date of application.
3. Selection criteria is subject to change. See a Health Science Counselor for current selection criteria.
4. Upon selection for the program but prior to the start of classes, the candidate will be required to obtain a physical examination and required immunizations.
5. Students selected for admission to the program must obtain a Health Care Provider level cardiopulmonary resuscitation (CPR) card prior to attending clinical training and must maintain current certification throughout the program.
6. If you have been convicted of a criminal offense, your eligibility to enroll in the program may be affected. All students will be fingerprinted and cleared by the FBI and Department of Justice (DOJ) before enrolling in PT 110 C.

ASSOCIATE IN SCIENCE DEGREE**PSYCHIATRIC TECHNOLOGY Program Code: 1S03790**

While the state of California does not require an Associate Degree for licensure as a Psychiatric Technician, the student may elect to earn one. To receive an Associate in Science Degree, the student must complete all Psychiatric Technician course requirements with a minimum grade of "C." At least 50% of the Psychiatric Technician course requirements must be completed at Cypress College. A minimum of 19 additional General Education/Graduation Requirements must be earned with an overall GPA of 2.0.

To earn an Associate Degree students must complete: (1) all major course requirements with a minimum grade of "C"; (2) 25 units of General Education Graduation Requirements; (3) the cultural diversity and reading requirements; (4) any elective courses to complete a minimum of 60 units; and, (5) have a minimum GPA of 2.0. At least 50% of all major course work must be completed at Cypress College.

Required courses are listed in suggested sequence:

Note: A current "C" cardiopulmonary resuscitation (CPR) certification must be maintained by all students admitted to the program.

Prerequisite Courses:

Course #	Title	Units
*BIOL 160 C	Integrated Medical Science	3
*PSY 101 C	Introduction to Psychology	3
		<hr/> 6

SEMESTER 1

PT 110 C	Nursing Science I	7
PT 115 C	Nursing Science II	7
*PSY 139 C	Developmental Psychology	3
		<hr/> 17

SEMESTER 2

PT 120 C	Developmental Disabilities I	7.5
PT 125 C	Developmental Disabilities II	6.5
		<hr/> 14

SEMESTER 3

PT 130 C	Mental Disabilities I	6.5
PT 135 C	Mental Disabilities II	7.5
		<hr/> 14

Total Units Required**51****Electives:**

*COUN 140 C	Educational Planning	.5
HS 080 C	Selected Topics in Nursing and Allied Health	1

*Courses may be taken without official acceptance into the program. All other required courses must be taken after official acceptance.

All general education units may be taken prior to enrollment in the program or at the completion of the course work required by the BVNPT for licensure eligibility.

PSYCHIATRIC TECHNOLOGY**CERTIFICATE****Program Code: 1C21116**

This program aims to prepare a student to meet the requirements for licensure as a Psychiatric Technician in the state of California. A Psychiatric Technician is a licensed member of the professional health-care services team working with people who are emotionally or developmentally disabled. Historically employed by private and state mental hospitals, developmental centers, and many community facilities. Psychiatric Technicians will increasingly find a variety of jobs available in the fields of prisons/corrections and human services. These include day care centers, substance abuse programs, forensic facilities, special education and many other areas promoting mental health. The program is accredited by and conforms to the regulations of the California Board of Vocational Nurses and Psychiatric Technicians. Upon successful completion of the program, graduates are eligible to take the State Board Licensure Examination.

To earn a certificate, students must complete the required courses with a minimum grade of "C." At least 50% of all course work must be completed at Cypress College. Upon completion of the 51 units of required course work, the student becomes eligible to apply to the BVNPT for licensure examination.

Prerequisite Courses:

BIOL 160 C	Integrated Medical Sciences	3
PSY 101 C	Introduction to Psychology	3

SEMESTER 1

PT 110 C	Nursing Science I	7
PT 115 C	Nursing Science II	7
PSY 139 C	Developmental Psychology	3

SEMESTER 2

PT 120 C	Developmental Disabilities I	7.5
PT 125 C	Developmental Disabilities II	6.5

SEMESTER 3

PT 130 C	Mental Disabilities I	6.5
PT 135 C	Mental Disabilities II	7.5
		<hr/> 14

Total Units Required**51****Electives:**

COUN 140 C	Educational Planning	.5
HS 080 C	Selected Topics in Nursing and Allied Health	1

*A score of 3 or higher on the Advanced Placement (AP) Psychology exam meets this requirement upon petition through Admissions and Records. See a counselor for more information.

Psychiatric Technology (PT)**PT 080 C Sel Topics/Psychiatric Technol****1 Unit**

Term hours: 16–18 lecture. This course is designed to meet the health science student's need for current topics and issues, updated information in health care, review of specialized subject matter, and/or preparation for health related licensure and certification exams. Content will emphasize clinical application of theoretical principles in the discipline. Resource materials, instructor assessment of individual student knowledge and skills will be utilized. May be taken for credit 4 times. Pass/No Pass/Letter Grade Option.

PT 085 C Psychiatric Technician — Wk Exp 1 to 4 Units*Prerequisite: Concurrent enrollment in Psychiatric Technician Program.*

Term hours: 16–18 lecture and 80 hours (minimum) related employment. This course provides practical work experience for students caring for individuals with developmental disabilities in community settings. May be taken for credit 4 times. Pass/No Pass/Letter Grade Option.

PT 110 C Nursing Science I 7 Units*Prerequisite: Acceptance into the Psychiatric Technology Program.*

Term hours: 72–81 lecture and 120–135 laboratory. This course presents fundamental concepts and scientific principles of nursing care. It begins to prepare students for the safe administration of medications by introducing them to the modern systems of measurement. Principles discussed in lecture will be applied in the clinical setting. (CSU)

PT 115 C Nursing Science II — Lecture 7 Units*Prerequisite: PT 110 C.*

Term hours: 72–81 lecture and 120–135 laboratory. This course explores the disease process of medical/surgical conditions relative to etiology, pathology, and treatment modalities. The therapeutic use of medication, the principles of nutrition, and the application of the nursing process are presented in classroom instruction and implemented in clinical practice. (CSU)

PT 120 C Developmental Disabilities I — Lecture 7.5 Units*Prerequisite: PT 115 C and PSY 139 C.*

Term hours: 72–81 lecture and 144–162 laboratory. This course explores the philosophy and principles directing the delivery of care and service to persons with developmental disabilities residing in California. Students learn how to teach self-help and independent living skills to persons with developmental disabilities. (CSU)

PT 125 C Developmental Disabilities II 6.5 Units*Prerequisite: PT 120 C.*

Term hours: 48–54 lecture and 168–189 laboratory. This course focuses on the cause and treatment of developmental disabilities. The theory and application of behavioral techniques advocating only the presentation and removal of positive reinforcement is presented. Pharmacological interventions and special dietary needs are also covered. (CSU)

PT 130 C Mental Disabilities I — Lecture 6.5 Units*Prerequisite: PT 125 C.*

Term hours: 48–54 lecture and 168–189 laboratory. This course is designed to assist the student in caring for the mentally disabled client at the tertiary level of intervention. Emphasis is placed on assessment and intervention of the chronically hospitalized individual. (CSU)

PT 135 C Mental Disabilities II — Lecture 7.5 Units*Prerequisite: PT 130 C.*

Term hours: 72–81 lecture and 144–162 laboratory. This course prepares the student to intervene at the primary and secondary levels of treatment in the care of individuals with mental disabilities. Primary interventions include prevention of mental disabilities through the education of individuals at risk, while secondary interventions are aimed at identified clients during periods of increased stress. (CSU)

Psychology

Division of Social Sciences

*Division Dean — Nina DeMarkey**Faculty*

Susan Johnson
Randall Martinez
Carlos Sandoval
Brandy Young

Counselors

Velia Lawson
Therese Mosqueda-Ponce
Daniel Pelletier

PROGRAM LEARNING OUTCOMES (PLOs)

The courses taught by this department contribute to the General Education and Basic Skills Program Learning Outcomes. Please refer to General Education and Basic Skills Program Learning Outcomes.

ASSOCIATE OF ARTS DEGREE IN PSYCHOLOGY FOR TRANSFER Program Code: 1A31353

This curriculum is designed to provide an opportunity for the Psychology major to achieve an Associate in Arts Degree in Psychology for Transfer (AA-T in Psychology) which completes the first and second year requirements for transfer to a four-year public California institution.

While at least a baccalaureate degree is recommended preparation for those considering professional careers, completion of this curriculum will demonstrate commitment to the field and provide comprehensive preparation for further academic study through upper-division course work. This curriculum specifically prepares the prospective transfer student for upper division coursework in Psychology or a similar major at a California State University (CSU) campus. Students should consult a counselor, the Transfer Center and the catalog of the transfer-college or university to plan a specific program of study to meet the college or university's requirements. **Note:** Courses that fulfill major requirements for an Associate Degree for Transfer at Cypress College might not be the same as those required for completing the major at all transfer institutions offering a Baccalaureate Degree.

The Student Transfer Achievement Reform Act (Senate Bill 1440, now codified in California Education Code sections 66746–66749) guarantees admission to a California State University (CSU) campus for any community college student who completes an “associate degree for transfer,” a newly established variation of the associate degrees traditionally offered at a California community college. The AA-T is intended for students who plan to complete a bachelor's degree in a similar major at a CSU campus. Students completing these degrees (AA-T) are guaranteed admission to the CSU system, but not to a particular campus or major. Students transferring to a CSU campus that does accept the AA-T will be required to complete no more than 60 units after transfer to earn a bachelor's degree (unless the major is designated “high-unit” major). This degree may not be the best option for students intending to transfer to a particular CSU campus or to a university or college that is not part of the CSU system. Students should consult with a counselor when planning to complete the degree for more information on university admission and transfer requirements.

Students successfully completing the AA-T in Psychology will acquire a fundamental knowledge base of psychology, learn basic knowledge and skills in data analysis and research methods, and possess a basic understanding of areas that have an interdisciplinary association to Psychology. This degree will provide students with an introduction to the field including its scientific foundations and applied areas. The intent is to prepare students for further academic study in the field. It will also demonstrate commitment to the field and provide comprehensive preparation for upper division work at the university level. At the baccalaureate level students can continue an education in various areas of psychology including research methods, cognition, physiological psychology, development, environmental psychology, organizational psychology, clinical psychology, and educational psychology. Graduate study is important in Psychology. Those holding a Master's or Doctoral degree may find employment in teaching, research, private practice, or welfare and health related fields. Those without a graduate degree will find limited career opportunity in direct areas of Psychology.

To earn an AA-T in Psychology students must complete the following requirements: (1) a minimum of 20 semester units or 30 quarter units in the Psychology major with a minimum grade of "C"; (2) California State University General Education Breadth requirements (CSU GE Breadth) or the Intersegmental General Education Transfer Curriculum (IGETC); (3) elective courses to complete a minimum of 60 units of CSU transferable coursework; (4) have an overall GPA of 2.0.

Required Core Courses: (11 units)		Units
PSY 101 C	Introduction to Psychology	3
PSY 161 C	Probability and Statistics — Social Science	4
	or	
SOC 161 C	Probability and Statistics — Social Science	(4)
PSY 202 C	Research Methods in Psychology	4

List A: Select one course of three (3) to five (5) units.		Units
PSY 221 C	The Brain and Behavior	3
BIOL 101 C	General Biology	5

List B: Select one of the following three (3) unit courses, or any course not taken in List A (3–5 units)		Units
PSY 139 C	Developmental Psychology	3
PSY 222 C	Abnormal Psychology	3

List C: Select one of the following as a three (3) unit Psychology course not selected in List A or List B or one of the following:		Units
PSY 110 C	Applied Psychology	3
PSY 120 C	Human Sexuality	3
	or	
SOC 120 C	Human Sexuality	(3)
PSY 145 C	Child Psychology	3
PSY 237 C	Cross-Cultural Relationships	3
	or	
SOC 237 C	Cross-Cultural Relationships	(3)
PSY 251 C	Social Psychology	3
PSY 255 C	Psychology of Aging	3
	or	
HUSR 255 C	Psychology of Aging	(3)
Total Units		20–24

PSYCHOLOGY TRANSFER PROGRAM

Students should consult a counselor or www.assist.org for lower division major requirements for most California public universities. (See the Standard Definitions section of the catalog for a description of ASSIST.) Students transferring to an independent college/university should consult the catalog of the individual school and a counselor for lower division major requirements.

Psychology (PSY)

PSY 101 C Introduction to Psychology **3 Units**

Advisory: Eligibility for ENGL 100 C.

Term hours: 48–54 lecture. This course is a scientific consideration of the psychological foundations of behavior. It will investigate psychological development, motivation, sensation, perception, learning, thinking, language, psychological measurement, and principles of mental illness and mental health. Duplicate credit not granted for PSY 101HC. (UC/CSU, AA GE, CSU GE, IGETC)

PSY 101HC Honors Introduction to Psychology **3 Units**

Advisory: Eligibility for ENGL 100 C.

Term hours: 48–54 lecture. This course, enriched for honors students, is a scientific introduction to the major areas of psychology. These areas include research methodology, consciousness, cognition, memory, perception, sensation, motivation, emotion, learning, development, personality, abnormal psychology, and physiological psychology. Students will examine, demonstrate and critique principles, theories, and research on human cognition, emotion, behavior, and conscious experience. The course uses lecture, multimedia presentation, class discussion, online communication, simulations, online resources, and research projects to enhance the learning experience of students. Duplicate credit not granted for PSY 101 C. (UC/CSU, AA GE, CSU GE, IGETC)

PSY 110 C Applied Psychology **3 Units**

Term hours: 48–54 lecture. This course examines the principles of psychology and its research as it applies to everyday living. These principles are explored in the context of college life, interpersonal relationships, work and career. Focus areas include adjustment, health, stress, sexuality and psychological disorders. Applied Psychology is not the same as PSY 101 C Introduction to Psychology and cannot be taken in place of PSY 101 C. (CSU, CSU GE)

PSY 120 C Human Sexuality **3 Units**

Same as SOC 120 C.

Advisory: Eligibility for ENGL 100 C.

Term hours: 48–54 lecture. This course is an overview of the psychological, sociological and psychobiological aspects of human sexuality. The course takes an interdisciplinary approach dealing with the entire area of human sexual behavior viewed in the context of the total integrated personality. Duplicate credit not granted for SOC 120 C. (UC/CSU, AA GE, CSU GE, IGETC)

PSY 139 C Developmental Psychology **3 Units**

Advisory: Eligibility for ENGL 100 C.

Term hours: 48–54 lecture. This is a study of emotional, intellectual, social and physical growth patterns from conception to death. It emphasizes an integrated approach to each life phase. It also examines the influence of heredity and environment in the life span. The study also includes applicable theories of development. (UC/CSU, CSU GE, IGETC)

PSY 145 C Child Psychology **3 Units**

Advisory: Eligibility for ENGL 100 C.

Term hours: 48–54 lecture. This course explores physical, cognitive, communicative/linguistic, and socio-emotional development of the child from conception through adolescence across diverse cultures with emphasis on the learning process. Education and teaching issues related to children are highlighted. (UC/CSU, AA GE, CSU GE, IGETC)

PSY 161 C Probability and Statistics —**Social Sciences****4 Units**

Same as SOC 161 C.

Prerequisite: MATH 040 C or Algebra II with a grade of “C” or better and the assessment process.

Term hours 64–72 lecture. This course provides an introduction to fundamental statistical concepts relevant to the social sciences but applicable to all disciplines. A conceptual approach is used to introduce students to topics of descriptive and inferential statistics including sampling, probability, central tendency, variability, correlation, regression, point estimation, interval estimation, and hypothesis testing. Also introduced are non-parametric statistics, such as chi-square, and parametric statistics, such as t-tests and ANOVA. Computers and calculators will be utilized. The use of current statistical software is emphasized. Data sets and problems will be from psychology, sociology, anthropology, economics, geography, and political science. This course is open to all students who meet the prerequisite, and it is required for psychology majors. This course is strongly recommended for all social science majors. Students who receive credit for this course may not receive credit for MATH 120 C. Duplicate credit not granted for PSY 161HC, SOC 161 C, or SOC 161HC. (UC Credit Limitation/CSU, AA GE, CSU GE, IGETC)

PSY 161HC Honors Probability and Statistics —**Social Sciences****4 Units**

Same as SOC 161HC.

Prerequisite: MATH 040 C or Algebra II with a grade of “C” and the assessment process.

Term hours: 64–72 lecture. This honors course provides an introduction to fundamental statistical concepts relevant to the social sciences but applicable to all disciplines. A conceptual approach is used to introduce students to topics of descriptive and inferential statistics including sampling, probability, central tendency, variability, correlation, regression, point estimation, interval estimation, and hypothesis testing. Also introduced are non-parametric statistics, such as chi-square, and parametric statistics, such as t-tests and ANOVA. Computers and calculators will be utilized. The use of current statistical software is emphasized. Data sets and problems will be from psychology, sociology, anthropology, economics, geography, and political science. This course is open to all students who meet the prerequisite, and it is required for psychology majors. This course is strongly recommended for all social sciences majors. Students who receive credit for this course may not receive credit for MATH 120 C. Duplicate credit not granted for PSY 161 C, SOC 161 C, or SOC 161HC. (UC/CSU, AA GE, CSU GE, IGETC)

PSY 202 C Research Methods in Psychology**4 Units***Prerequisite: PSY 101 C and PSY 161 C.*

Term hours: 48–54 lecture and 48–54 laboratory. This course encompasses the conceptual, ethical and technical aspects of designing and implementing research in the cognitive, behavioral and social sciences. Concepts are presented for proper application of the scientific method to psychological and social research using quantitative and qualitative techniques. The use of current technology to acquire, process, and analyze data is integrated throughout the course. Emphasis is placed on proper communication and presentation of completed research. (UC/CSU, CSU GE, IGETC)

PSY 212 C Understanding Child Trauma and the**Effects of Abuse****3 Units**

Term hours: 48–54 lecture. This course examines the causes of child abuse and traumatization, the effects of trauma, and commonly accepted ways to assist children of trauma. Trauma includes the effects of abuse, neglect, witnessing, and experiencing extraordinary events. Legal and foster care issues will also be investigated. (CSU)

PSY 215 C Parenting Skills**3 Units**

Same as SOC 215 C.

Term hours: 48–54 lecture. This course is designed to build realistic expectations in parenting. Students will acquire parenting skills and deal constructively with varied aspects of child rearing. A special emphasis will be placed on reviewing contemporary discipline and guidance techniques and on exploring resources available in the community for parenting. The course includes developmental states from birth through adulthood. (CSU)

PSY 221 C The Brain and Behavior**3 Units***Prerequisite: PSY 101 C with a grade of “C” or better.*

Term hours: 48–54 lecture. This course examines the neurophysiological processes associated with mental processes and behavior. Emphasis is placed on the structure and function of the brain and other central nervous system structures. Related processes such as the autonomic nervous system, the endocrine system and the immune system are also studied. Specific topics studied in the context of the brain include learning, sensation, perception, emotion, motivation, cognition, memory, stress, psychological disorders, and brain dysfunctions. (UC/CSU, CSU GE, IGETC)

PSY 222 C Abnormal Psychology**3 Units***Prerequisite: PSY 101 C with a grade of “C” or better.*

Term hours: 48–54 lecture. This course is a systematic study of psychopathology. It is concerned with consciousness expressed through behavior that is considered to be counterproductive, maladaptive, and disruptive to the individual and/or society. The course will consider disturbances of volition, thinking, and feeling. Students in this case-driven course will be required to understand the current version of the DSM and apply the multi-axial assessment to videotaped cases of actual patients. The taped cases will illustrate a specific Axis I or Axis II disorder and provide information sufficient for the student to make a clear diagnosis. (UC/CSU, CSU GE, IGETC)

PSY 237 C Cross-Cultural Relationships**3 Units**

Same as SOC 237 C.

Advisory: Eligibility for ENGL 100 C.

Term hours: 48–54 lecture. This course is an introduction to the psychological factors involved in cross-cultural relationships including ethnic and racial differences. It explores personal processes and individual conflicts of people from differing United States ethnic backgrounds. Varying customs, social patterns and family dynamics of major local cultural groups will be discussed within this context. (UC/CSU, CSU GE, IGETC, CUL DIV)

PSY 240 C Child Development and Education**3 Units**

Term hours: 48–54 lecture. This course explores the physical, cognitive, communicative/linguistic, and socio-emotional development of the child from conception through adolescence across diverse cultures with an emphasis on the learning process. Education and teaching issues related to children are highlighted. (CSU, AA GE, CSU GE)

PSY 251 C Social Psychology**3 Units***Advisory: PSY 101 C with a grade of “C” or better.*

Term hours: 48–54 lecture. This course examines the basic theories, concepts, and empirical findings in such areas as social perception, social cognition, prejudice, discrimination, interpersonal attraction, conformity and obedience, by-stander effects, social aggression, group dynamics, attribution theory, and development of self in the social setting. (UC/CSU, AA GE, CSU GE, IGETC)

PSY 255 C Psychology of Aging**3 Units**

Same as HUSR 255 C.

Term hours: 48–54 lecture. This course examines the biological, physiological, cognitive, developmental, and sexual aspects of the ongoing aging process. Critical life issues for elders and for those who live and work with them will be explored. These issues include physical health, mental health, health care policy, care giving, dependency, and positive aging strategies. Duplicate credit not granted for HUSR 255 C. (UC/CSU, AA GE, CSU GE, IGETC)

PSY 298 C Psychology Seminar**.5 to 12 Units***Prerequisite: May be required.**Corequisite: May be required.**Advisory: May be required.*

Term hours: 0–216 lecture and/or 0–648 laboratory depending on units attempted. This is a lecture/discussion type course developed on a particular limited problem or topic of interest to students. It is designed for able students who wish to increase their knowledge of a particular topic concerning which no other regular class is offered. A paper or group activity may be requested. Credit may range from .5 units to 12 units. Consult class schedule for the offerings a particular semester. May be taken for credit 1–4 times. Pass/No Pass or Pass/No Pass/Letter Grade Option or Standard Letter Grade. Fees may be required — Payable at Registration. (UC Credit Limitation/CSU)

PSY 299 C Psychology Independent Study**1 Unit***Prerequisite: Approved Independent Study Learning Contract.*

Varying hours of scheduled conferences per week according to instructor. Independent study is for able students who wish to extend their knowledge of a particular area through individual research and study. It is thought that topics might develop out of a curiosity stimulated in a regular class. The student would then contact the supervising instructor to develop a contract for his/her particular interest so that they could learn more regarding their special topic. May be taken for credit 3 times. (UC Credit Limitation/CSU)

Radiologic Technology

Division of Health Science

Division Dean — John Sciacca*Faculty*

Michael Frianeza

Laura Greico

Lynn Mitts

Counselors

Kelly Carter

Denise Vo

PROGRAM LEARNING OUTCOMES (PLOs)

Radiologic Technology

A student who completes the Radiologic Technology program will be able to:

- Apply positioning skills in all required radiographic examinations.
- Select appropriate technical factors for radiographic examinations.
- Practice radiation protection for all radiographic examination.
- Employ proper patient care techniques.
- Demonstrate oral communication skills.
- Demonstrate written communication skills.
- Relate to and anticipate the needs of the doctors and technologists.
- Adjust to changes, situations, patient conditions, and deviation from the normal routine.
- Demonstrate knowledge of ethical requirements for an entry level radiographer along with ethical practices in a healthcare setting.
- Understand his/her professional obligations upon gaining the ARRT status.

ASSOCIATE IN SCIENCE DEGREE RADIOLOGIC TECHNOLOGY PROGRAM

Program Code: 1S03789

MISSION STATEMENT

The Cypress College Department of Radiologic Technology provides a high quality education to prepare a diverse population of students with entry level skills needed to become competent and confident radiographers. Radiology Program Goals

1. Students will have the knowledge and skills to competently and safely perform radiographic procedures.
2. Students will develop the skills necessary to communicate effectively.
3. Students will use critical thinking and problem solving skills.
4. Students will evaluate the importance of professional development and growth.
5. The program will provide the community with entry level radiographers for employment in the healthcare setting.

JRCERT

20 North Wacker Drive, Suite 2850

Chicago, IL 60606-3182

(312) 704-5300

(312) 704-5304 (FAX)

email: mail@jrcert.org

www.jrcert.org

PROGRAM GOALS AND OBJECTIVES

1. To provide students with a balance of instruction in radiologic technology courses as well as support courses.
2. To provide students with knowledge and skill to perform radiologic technology procedures.
3. To facilitate development of applied skills in effective communication, critical thinking, and problem solving in the practice of radiography.
4. To provide clinical experience compliment didactic instruction and develop clinical skills required for professional practice.
5. To provide an environment that encourages personal and professional growth.
6. To promote values of compassion, respect, understanding, and dignity in providing care to patients during imaging procedures.
7. To provide the health care community with graduate entry level radiographers skilled in diagnostic imaging procedures.

MINIMUM STANDARDS FOR APPLICANTS

1. Eligibility for admission to Cypress College.
2. High school graduation, or completion of the General Education Development (GED) test, or high school proficiency test.
3. Minimum age of 17 years.
4. Present evidence of good physical and mental health, as determined by medical examination upon admission to program and prior to enrollment.
5. Overall GPA of 2.0 in all college classes taken.
6. Must have own transportation to all affiliated hospitals.
7. Eligibility for ENGL 100 C.
8. Completion of 9 units of General Education. (See General Education requirements in catalog.)
9. Enrollment in, or completion of, program prerequisites.

APPLICATION PROCEDURES

1. A separate application, in addition to the college application form, is required for admission into the Radiologic Technology program.
2. Application must be completed **online** during the month of **February**. Please see the **Health Science Application link** on the Radiology Technology home page.
3. Applicants must submit official transcripts (except Cypress and Fullerton Colleges) and signature page of application **in person** to the Health Science Applications office, Health Science Building, Cypress College 9200 Valley View Street, Cypress, California 90630-5897 by **March 15**. Please bring photo identification.
4. It is the applicant's responsibility to verify that evidence of criteria is on file.

SELECTION PROCEDURES

1. Applications normally exceed capacity. Selection of applicants is based on accumulation of points. (Criteria is subject to change. For information see a Health Science Counselor.)

PROGRAM PREREQUISITES

Foundation courses are required prior to admission to the program. The following required courses plus a minimum of 9 general education units must be completed by the end of the spring semester with a minimum grade of "C" in each course to be considered for the fall (August) class.

HS 145 C	Survey of Medical Terminology	3
BIOL 210 C	Anatomy and Physiology or	5
BIOL 231 C	General Human Anatomy	(4)
RADT 142 C	Radiologic Electronics	4
RADT 146 C	Introduction to Radiography	4
MATH 040 C	Intermediate Algebra	4

After receiving the degree and after completing the clinical internship, the student will be eligible to apply for admission to the state examination and the certification examination administered by the American Registry of Radiologic Technologists (ARRT). The program in Radiography is accredited by the Joint Review Committee on Education in Radiologic Technology (JRCERT).

JRCERT

20 North Wacker Drive, Suite 2850
Chicago, IL 60606-3182
(312) 704-5300
(312) 704-5304 (FAX)
email: mail@jrcert.org
www.jrcert.org

RADIOLOGIC TECHNOLOGY CURRICULUM

Radiologic Technology courses must be taken in a specific sequence. Students must obtain a minimum grade of "C" in all required courses to continue in the program. The three (3) semester internships will begin during the summer session following semester 2 of the curriculum and continue until June of the following year.

All courses, including general education courses, to satisfy the Associate Degree (refer to Cypress' Associate Degree requirements) must be completed prior to the end of the internship year. Upon completion of the program and Associate Degree requirements, the student will be eligible for the State Certification and National Registry Examinations. For further information, contact a Health Science Counselor, (714) 484-7270.

To earn an Associate Degree students must complete: (1) all major course requirements with a minimum grade of "C"; (2) 25 units of General Education Graduation Requirements with a grade of "C" or better; (3) the cultural diversity and reading requirements with a "C" or better; (4) any elective courses to complete a minimum of 60 units; and, (5) have a minimum GPA of 2.0. At least 50% of all major course work must be completed at Cypress College. The student will be able to complete the radiologic technology program including the foundation courses and general education courses in six semesters and one summer session as a full time student.

Required Courses are listed in suggested sequence:

		Units
SEMESTER 1		
RADT 148 C	Radiologic Technology	4
RADT 150 C	Radiologic Positioning	5
RADT 153 C	Radiography Patient Care	3
HS 147 C	Survey of Disease	3
SEMESTER 2		
RADT 247 C	Radiographic Positioning	5
RADT 251 C	Radiology Externship	7
RADT 162 C	Radiology Special Procedures	3
RADT 252 C	Radiobiology	1.5
RADT 253 C	Radiation Laws and Ethics	1.5
SUMMER INTERSESSION		
RADT 254 C	Radiologic Internship	6.5
RADT 196 C	Radiography — Selected Topics	1–2
SEMESTER 3		
RADT 255 C	Radiologic Internship	12
RADT 196 C	Radiography — Selected Topics	1–2
RADT 260 C	Fluoroscopy Permit Course	3
SEMESTER 4		
RADT 255 C	Radiologic Internship	12
RADT 196 C	Radiography — Selected Topics	1–2

Note: Non-refundable supplemental materials charges will apply to some of the above courses in this program.

Total Units **69.5–72.5**

CONTINUING EDUCATION COURSES

		Units
RADT 264 C	Vascular Sonography Technology	3
RADT 266 C	Principles of Breast Ultrasound	3
RADT 262 C	Cross-Sectional Imaging	1

IMAGING TECHNOLOGIST ASSISTANT CERTIFICATE

Program Code: 1C10449

The Imaging Technologist Assistant Program prepares a student for an entry-level position as an imaging assistant in a health care facility such as a hospital, private physician's office, or clinic. This program can be completed in one year. To earn a certificate the student must complete the 16 units of required courses with a minimum grade of "C." At least 50% of all course work must be completed at Cypress College.

Required courses are listed in suggested sequence:

		Units
ENGL 100 C	College Writing	3
HS 145 C	Survey of Medical Terminology	3
CIS 111 C	Computer Information Systems	3
RADT 153 C	Radiography Patient Care	3
RADT 146 C	Introduction to Radiography	4
Total Units		16

RADIOLOGIC TECHNOLOGY CERTIFICATE

Program Code: 1C21114

To earn a certificate, students must have previously earned an Associate Degree and have completed all of the Cypress College Radiologic Technology Program requirements with a minimum grade of "C." At least 50% of all course work must be completed at Cypress College.

MINIMUM STANDARDS FOR APPLICANTS

1. Eligibility for admission to Cypress College.
2. High school graduation, or completion of the General Education Development (GED) test, or high school proficiency test.
3. Minimum age of 17 years.
4. Present evidence of good physical and mental health, as determined by medical examination upon admission to program and prior to enrollment.
5. Overall GPA of 2.0 in all college classes taken.
6. Must have own transportation to all affiliated hospitals.
7. Eligibility for ENGL 100 C.
8. Completion of 9 units of General Education. (See General Education requirements in catalog.)
9. Enrollment in, or completion of, program prerequisites.

APPLICATION PROCEDURES

1. A separate application, in addition to the college application form, is required for admission into the Radiologic Technology program.
2. Applications must be completed **online** during the month of **February**. Please see the **Health Science Application link** on the Radiology Technology home page.
3. Applicants must submit official transcripts (except Cypress and Fullerton Colleges) and signature page of application **in person** to the Health Science Applications office, Health Science Building, Cypress College, 9200 Valley View Street, Cypress, California 90630-5897 by **March 15**. Please bring photo identification.
4. It is the applicant's responsibility to verify that evidence of criteria is on file.

SELECTION PROCEDURES

Applications normally exceed capacity. Selection of applicants is based on accumulation of points. (Criteria is subject to change. For information see a Health Science Counselor.)

PROGRAM PREREQUISITES

Foundation courses are required prior to admission to the program. The following required courses plus a minimum of 9 general education units must be completed by the end of the spring semester with a minimum grade of "C" in each course to be considered for the fall (August) class.

Course #	Title	Units
HS 145 C	Survey of Medical Terminology	3
BIOL 210 C	Anatomy and Physiology	5
BIOL 231 C	General Human Anatomy	(4)
RADT 142 C	Radiologic Electronics	4
RADT 146 C	Introduction to Radiography	4
MATH 040 C	Intermediate Algebra	4

RADIOLOGIC TECHNOLOGY CURRICULUM

Radiologic Technology courses must be taken in a specific sequence. Students must obtain a minimum grade of "C" in all required courses to continue in the program. The three (3) semester internships will begin during the summer session following semester 2 of the curriculum and continue until June of the following year.

All courses, including general education courses, to satisfy the Associate Degree (refer to Cypress' Associate Degree requirements) must be completed prior to the end of the internship year. Upon completion of the program and Associate Degree requirements, the student will be eligible for the State Certification and National Registry Examinations. For further information, contact a Health Science Counselor, (714) 484-4270.

Required Courses are listed in suggested sequence:

		Units
SEMESTER 1		
RADT 148 C	Radiologic Technology	4
RADT 150 C	Radiologic Positioning	5
RADT 153 C *	Radiography Patient Care	3
HS 147 C *	Survey of Disease	3
SEMESTER 2		
RADT 247 C	Radiographic Positioning	5
RADT 251 C	Radiology Externship	7
RADT 162 C	Radiology Special Procedures	3
RADT 252 C	Radiobiology	1.5
RADT 253 C	Radiation Laws and Ethics	1.5
SUMMER INTERSESSION		
RADT 254 C	Radiologic Internship	6.5
RADT 196 C	Radiography — Selected Topics	1–2
SEMESTER 3		
RADT 255 C	Radiologic Internship	12
RADT 196 C	Radiography — Selected Topics	1–2
RADT 260 C	Fluoroscopy Permit Course	3
SEMESTER 4		
RADT 255 C	Radiologic Internship	12
RADT 196 C	Radiography — Selected Topics	1–2
Total Units		69.5–72.5

Note: Non-refundable supplemental materials charges will apply to some of the above courses in this program.

CONTINUING EDUCATION COURSES	Units
HSCE 260 C Fluoroscopy Permit Courses	3
HSCE 262 C Cross-Sectional Imaging	1

*May be taken prior to enrollment in program.

ULTRASOUND/MEDICAL SONOGRAPHY — now known as Diagnostic Medical Sonography and is located under this new name in the catalog.

Radiologic Technology (RADT)

RADT 142 C Radiologic Electronics **4 Units**

Term hours: 64–72 lecture. This is an introductory course for students preparing for courses in radiologic technology. Content is designed to establish a basic knowledge of the physics of mechanics, the physics of sound, and quantum physics to include the x-ray emission spectrum and x-ray interaction with matter. Also presented are the nature and characteristics of radiation, x-ray production and the fundamentals of photon interaction with matter. Basic knowledge in radiographic equipment and requirements will be discussed. (CSU)

RADT 146 C Introduction to Radiography 4 Units

Term hours: 64–72 lecture. This course is an introduction to radiologic technology. Content is designed to provide an overview of the foundations in radiography and the practitioner's role in the health care delivery system. Principles, practices, and policies of the health care organization(s) will be discussed and examined, in addition to the professional responsibilities of the radiographer. The course includes fundamentals of darkroom procedures, x-ray film characteristics, radiographic equipment and accessories, principles of radiation protection, and introduction to radiologic procedures and terminology. (CSU)

RADT 148 C Radiologic Technology 4 Units

Prerequisite: Admission to Radiologic Technology Program.
Term hours: 48–54 lecture and 48–54 laboratory. This course offers a study of the principles of radiographic exposure, geometry of radiographic image, factors influencing radiographic quality, beam restricting and attenuation devices. Included are the importance of minimum imaging standards, discussion of a problem solving technique for image evaluation and the factors that can affect image quality. Actual images will be included for analysis. Content will also provide a basic knowledge of quality control. \$50.00 Materials Fee — Payable at Registration. (CSU)

RADT 150 C Radiologic Positioning 5 Units

Prerequisite: Admission to Radiologic Technology Program.
Term hours: 64–72 lecture and 48–54 laboratory. This course offers positioning and nomenclature, positioning methods for the upper and lower extremities, pelvis, respiratory system, abdomen and bony thorax along with practical applications of radiograph evaluation and radiation protection. \$50.00 Material Fee — Payable at Registration. (CSU)

RADT 153 C Radiography Patient Care 3 Units

Term hours: 48–54 lecture. This course on patient care and management is a lecture/demonstration class to teach aseptic techniques and special procedures used by radiology personnel. It will include student participation in nursing techniques, techniques in areas such as: operating rooms; isolation room; diagnostic and fluoroscopic radiology rooms; the nursery; emergency room; and intensive care rooms. Students will be required to obtain CPR certification for this class. (CSU)

RADT 162 C Radiology Special Procedures 3 Units

Prerequisite: Satisfactory completion of first semester in the Radiologic Technology Program.
Term hours: 40–45 lecture and 24–27 laboratory. This course provides the student with the theory and practice of basic techniques of venipuncture and the administration of contrast media. Emphasis will be placed on the types of contrast agents used for the various radiographic procedures. The student will perform both simulated and live insertion and extraction for contrast media injection. Basic Pharmacology will be discussed. The student will be introduced to fundamental principles of computer technology for imaging modalities. Special imaging modalities such as: Digital Angiography; Computerized Tomography; Magnetic Resonance Imaging; Medical Sonography; Nuclear Medicine; and Radiation Therapy will be surveyed. \$22.00 Material Fee — Payable at Registration. (CSU)

RADT 196 C Radiography — Selected Topics 1 to 2 Units

Prerequisite: RADT 251 C.
Term hours: Lecture hours will vary according to credit given. Current trends and new advances in diagnostic imaging will be selected for intensive class discussion. This course will support the student in the clinical internship phase. Radiographic technique and actual case studies will be discussed. May be taken for credit 4 times. Pass/No Pass/Letter Grade Option. (CSU)

RADT 247 C Radiographic Positioning — Lecture 5 Units

Prerequisite: Satisfactory completion of first semester Radiologic Technology Program.
Term hours: 64–72 lecture and 48–54 laboratory. This course offers advanced positioning nomenclature, positioning methods for the skull, urinary systems, vertebral column, digestive system, arthrography, and myelography exams. Trauma positioning and techniques are also discussed along with radiograph evaluations and radiation protection for all procedures. \$33.00 Material Fee — Payable at Registration. (CSU)

RADT 251 C Radiology Externship 7 Units

Prerequisite: Satisfactory completion of the first semester in the Radiologic Technology Program and RADT 148 C, RADT 150 C and HS 147 C with minimum grades of "C."
Corequisite: RADT 162 C, RADT 247 C, RADT 252 C and RADT 253 C.
Term hours: 32–36 lecture and 256–288 hours in supervised training and observation in an approved clinical affiliate. This class provides an introduction to fluoroscopy, tomography, radiology, hysterosalpingography, and pediatric radiography. The clinical externship will provide training in an approved clinical affiliate. (CSU)

RADT 252 C Radiobiology 1.5 Units

Prerequisite: RADT 142 C and BIOL 231 C or BIOL 210 C and HS 145 C and RADT 146 C all with minimum grades of "C."
Term hours: 24–27 lecture. This course is designed to provide the principles of radiation interaction with molecules, cells, tissues, and the body as a whole. Factors affecting biological responses are presented, including early and late effects of radiation exposure. The principles of radiation protection along with the responsibilities of the radiographer for patients, personnel, and the public is included. (CSU)

RADT 253 C Radiation Laws and Ethics 1.5 Units

Prerequisite: RADT 153 C with a minimum grade of "C."
Term hours: 24–27 lecture. An introduction to legal terminology, concepts, and principles for radiographers will be presented. Topics include misconduct, malpractice, legal and professional standards and the scope of practice. The importance of proper documentation and informed consent is emphasized. The student will examine a variety of ethical issues and dilemmas found in clinical practice. (CSU)

RADT 254 C Radiologic Internship 6.5 Units

Prerequisite: RADT 162 C, RADT 247 C, RADT 251 C, RADT 252 C and RADT 253 C with minimum grades of "C."
Corequisite: RADT 196 C.
Term hours: 344–387 laboratory. This course begins the twelve month continuous internship phase of the Radiologic Technology Program. Students are assigned to selected clinical education centers which provide supervised clinical training with the Department of Radiology. Internship of 40 hours per week extend through intersessions and are subject to rearrangement by hospital/facility. Clinical practice experiences shall be designed to provide patient care and assessment, competent performance of radiologic imaging and total quality management. (CSU)

RADT 255 C Radiologic Internship 12 Units

Prerequisite: RADT 196 C and RADT 196 C with minimum grades of "C."
Term hours: 640–720 laboratory. This course begins the twelve month continuous internship phase of the Radiologic Technology Program. Students are assigned to selected clinical education centers which provide supervised clinical training with the Department of Radiology. Internship of 40 hours per week extends through intersessions and are subject to rearrangement by hospital/facility. Clinical practice experiences shall be designed to provide patient care and assessment, competent performance of radiologic imaging and total quality management. May be taken for credit 3 times. (CSU)

RADT 260 C Fluoroscopy Permit Course 3 Units

Prerequisite: Current California Radiologic Technology Certification License. Pass/No Pass/Letter Grade Option.

Term hours: 40–45 lecture and 24–27 laboratory. This course will provide the knowledge of skills, attitudes, and competencies to operate fluoroscopy equipment efficiently and safely. Upon successful completion of the course, students will receive a certificate of completion and be eligible to qualify for the California State Technologists Fluoroscopy Permit certification test. Students must be able to verify C.R.T. status at the first class meeting. (CSU)

RADT 262 C Cross-Sectional Imaging 1 Unit

Term hours: 16–18 lecture. This course correlates knowledge and practice of diagnostic imaging with cross-sectional anatomy of the skull, thorax, abdomen, and pelvis. Diagnostic imaging includes the ability to work with ultrasound, computerized tomography, and magnetic resonance. A knowledge of medical terminology and anatomy is recommended. Pass/No Pass/Letter Grade Option. (CSU)

RADT 264 C Vascular Sonography Technology 3 Units

Same as HSCE 264 C.

Prerequisite: A.R.D.M.S. (American Registry of Diagnostic Medical Sonographers) Registered Medical Sonographer and/or knowledge of basic ultrasound equipment and scanning techniques.

Term hours: 48–54 lecture. This course is the physical principles of vascular ultrasound technology. The course will focus toward learning the hemodynamic principles of normal and pathological vascular ultrasound procedures. Concepts of color and pulsed wave Doppler sonography as they apply to vascular imaging will be discussed. Emphasis on vascular anatomy, physiology and pathology to include vascular scanning protocol. Basic ultrasound physics and instrumentation will be reviewed. A working knowledge of basic ultrasound equipment, scanning techniques, and familiarity with color Doppler sonography is recommended. This course will prepare the student for the Registered Vascular Technology (RVT) examination. (CSU)

RADT 266 C Principles of Breast Ultrasound 3 Units

Same as HSCE 266 C.

Prerequisite: American Registry of Diagnostic Medical Sonography license and/or knowledge of basic ultrasound equipment and scanning techniques.

Term hours: 48–54 lecture. This course will provide instruction for learning the normal and pathological appearance of breasts using ultrasound to include images that relate to mammography and MRI. Included in this course is the physiology of benign and malignant breast tumors and diagnostic procedures. The content will follow the ARDMS guidelines toward the goal of preparing the student to pass the ultrasound registry breast exam. (CSU)

RADT 299 C Imaging Independent Study .5 to 2 Units

Prerequisite: Approved Independent Study Learning Contract.

Term hours: Lecture/lab hours will vary according to credit given. This course is designed for capable students enrolled in the Radiologic Technology program or options of the program who wish to increase their knowledge and experience in applied areas. Students will participate in independent study on assigned areas under staff supervision. May be taken for credit 4 times. (CSU)

Real Estate

Division of Business and Computer Information Systems

Division Dean — Dave Wassenaar

Counselor

Robert Grantham

Real Estate (RE)

RE 101 C Real Estate Principles 3 Units

Term hours: 48–54 lecture. This is a beginning course in real estate fundamentals and principles. The development of real estate in California and an introductory study of ownership, appraisal, law, practices, financing, land and location values, transfers, trends, regulations, and economic effects are stressed. Course fulfills educational prerequisites for California state licensure. (CSU)

RE 201 C Real Estate Practice 3 Units

Term hours: 48–54 lecture. This course covers professional aspects of the real estate business. Topics include an overview of the real estate industry, ethics and licensing requirements; hands-on completion of contracts, forms, and disclosure documents; prospecting strategies for obtaining clients; listing properties and servicing those listings; marketing techniques; strategies for showing property; obtaining and handling offers; closing sales transactions; financing, escrow, title and taxation issues; and 1031 exchange requirements for investment property. (CSU)

Recreation

Division of Physical Education and Athletics

Division Dean — Diane Henry

Faculty

Larry Beidler

Scott Pickler

Counselor

Dana Bedard

TRANSFER PROGRAM — RECREATIONAL LEADERSHIP

Students should consult a counselor or www.assist.org for lower division major requirements for most California public universities. (See the Standard Definitions section of the catalog for a description of ASSIST.) Students transferring to an independent college/university should consult the catalog of the individual school and a counselor for lower division major requirements.

Recreation (REC)

REC 100 C Introduction to Leisure Services/ Recreation

3 Units

Term hours: 48–54 lecture. This course is the foundation for an introduction to the broad field of recreation and leisure services. The class will include the relationship of recreation to the individual and society. (CSU)

REC 101 C Principles of Community Recreation

3 Units

Term hours: 48–54 lecture. This course is an introduction to a variety of recreational activities suitable for a community recreation program. The class will study the various agencies and institutions that provide opportunities for community recreation. The class will emphasize interrelationships of these agencies. (CSU)

REC 102 C Recreation Leadership

2 Units

Term hours: 32–36 lecture and 32–36 laboratory. This course will provide the theory and activity in teaching leadership in playground and recreational activities. The class will identify methods, techniques, planning procedures, organizing techniques, along with the evaluation of these procedures and techniques. (CSU)

REC 103 C Organizing Fall Sports Activity — Rec

2 Units

Term hours: 16–18 lecture and 32–36 laboratory. This course is a survey of basic terminology and skills of fall sports. The basic techniques of teaching, organizing, and promoting interest in individual and team fall sports are included. Students will be involved in organizing and promoting the college intramural sports program. (CSU)

REC 104 C Organizing Spring Sports Activity — Rec

2 Units

Term hours: 16–18 lecture and 32–36 laboratory. This course is a survey of basic terminology and skills of spring sports. The basic techniques of teaching, organizing, and promoting interest in individual and team spring sports are included. Students will be involved in organizing and promoting the college intramural sports program. (CSU)

REC 106 C Outdoor Recreation/Camp Counseling

3 Units

Term hours: 48–54 lecture. This course will emphasize the history, development and trends of organized camping and other outdoor recreation skills. The class will include leadership training in camp counseling with special emphasis on practical skills in camping, fire building, outdoor cooking, tenting, and camp crafts. This class is recommended for recreation majors and students interested in outdoor recreation. (CSU)

REC 107 C Recreation for Special Groups

3 Units

Term hours: 48–54 lecture. This class is an introduction to the relationships of recreation and special groups (i.e., teenagers, senior citizens, and the disabled). The course will emphasize social development and how to integrate special groups into recreation programs with adoption of all forms of recreation for use by these groups. (CSU)

REC 298 C Recreation Seminar

.5 to 12 Units

Prerequisite: May be required.

Corequisite: May be required.

Advisory: May be required.

Term hours: 0–216 lecture and/or 0–432 laboratory depending on units attempted. This class will utilize a lecture/lab-activity approach to various topics in recreation. A variety of classes will be offered in order to introduce students to new experiences in recreation. May be taken for credit 1–4 times. Pass/No Pass or Pass/No Pass/Letter Grade Option or Standard Letter Grade. Fees may be required — Payable at Registration. (CSU)

Secretarial —

See Computer Information Services (CIS)

Social Sciences

Division of Social Sciences

Division Dean — Nina DeMarkey

Counselors

Velia Lawson

Therese Mosqueda-Ponce

Daniel Pelletier

Social Science (SOSC)

SOSC 295 C Research Methods — Oral History

2 Units

Same as HIST 295 C.

Term hours: 16–18 lecture and 48–54 laboratory. This course introduces students to the special techniques of tape-recorded interviews to document 20th century history. Areas of study will include interviewing techniques, historical editing and transcripts of interviews. This course does not satisfy General Education requirements in Social Science. (CSU)

SOSC 298 C Social Sciences Seminar

.5 to 12 Units

Prerequisite: May be required.

Corequisite: May be required.

Advisory: May be required.

Term hours: 0–216 and/or 432 laboratory depending on units attempted. This is a lecture/discussion type course developed on a particular limited problem or topic of interest to students. It is designed for able students who wish to increase their knowledge of a particular topic concerning which no other regular class is offered. A paper or group activity may be requested. Credit may range from .5 units to 12 units. Consult class schedule for the offerings a particular semester. May be taken for credit 1–4 times. Pass/No Pass or Pass/No Pass/Letter Grade Option or Standard Letter Grade. Fees may be required — Payable at Registration. (UC Credit Limitation/CSU)

SOSC 299 C Social Sciences — Independent Study

1 Unit

Prerequisite: Approved Independent Study Learning Contract.

Term hours: 16–18 lecture. Independent study is for students who wish to extend their knowledge of a particular area through individual research and study. It is thought that topics might develop out of a curiosity stimulated in a regular class. The student would then contact the supervising instructor to develop a contract for his/her particular interest so he/she could learn more regarding their special topic. May be taken for credit 4 times. (UC Credit Limitation/CSU)

Sociology

Division of Social Sciences

Division Dean — Nina DeMarkey

Faculty

Larry Curiel
James Dedic
Regina Rhymes

Counselors

Velia Lawson
Therese Mosqueda-Ponce
Daniel Pelletier

PROGRAM LEARNING OUTCOMES (PLOs)

The courses taught by this department contribute to the General Education and Basic Skills Program Learning Outcomes. Please refer to General Education and Basic Skills Program Learning Outcomes.

ASSOCIATE IN ARTS IN SOCIOLOGY FOR TRANSFER DEGREE Program Code: 1S31003

This curriculum is designed to provide an opportunity for the Sociology major to achieve an Associate in Arts in Sociology for Transfer Degree which completes the first and second year requirements for transfer to a four-year public California institution. While at least a baccalaureate degree is recommended preparation for those considering professional careers, completion of this curriculum will demonstrate commitment to the field and provide comprehensive preparation for further academic study through upper-division course work at a four-year college or university. Students should consult a counselor, the Transfer Center and the catalog of the transfer college or university to plan a specific program of study to meet the college or university's requirements. Courses that fulfill major requirements for an Associate Degree for Transfer at Cypress College might not be the same as those required for completing the major at all transfer institutions offering a Baccalaureate Degree.

The Associate in Arts in Sociology for Transfer Degree is designed to provide students with an introduction and overview of the field. Sociology is the study of social life, social systems, social change and the social causes and consequences of human behavior. It is based on the idea that the understanding of the dynamic structure of social life will allow analysis of present situations against the backdrop of larger social realities and lead to effective responses to those situations. The Sociology Degree for Transfer program includes the study of sociological theories and knowledge, the scientific foundations of sociology, and the application of the sociological perspective to various, specific areas of social life. It offers an opportunity to examine the field in detail and to identify possible personal directions for further study. Sociology gives students a solid basis for many career paths and can be enhanced with multidisciplinary study in related fields. The Student Transfer Achievement Reform Act (Senate Bill 1440, now codified in California Education Code sections 66746–66749) guarantees admission to a California State University (CSU) campus for any community college student who completes an “associate degree for transfer,” a newly established variation of the associate degrees traditionally offered at a California community college. The Associate in Arts for Transfer (AA-T) is intended for students who plan to complete a bachelor's degree in

a similar major at a CSU campus. Students completing these degrees (AA-T) are guaranteed admission to the CSU system, but not to a particular campus or major. Students transferring to a CSU campus that does accept the AA-T will be required to complete no more than 60 units after transfer to earn a bachelor's degree (unless the major is designated “high-unit” major). This degree may not be the best option for students intending to transfer to a particular CSU campus or to a university or college that is not part of the CSU system. Students should consult with a counselor when planning to complete the degree for more information on university admission and transfer requirements.

To earn an Associate in Arts for Transfer (AA-T) students must complete: (1) 18 units of major course requirements with a minimum grade of “C”; (2) California State University General Education Breadth requirements (CSU GE Breadth) or the Intersegmental General Education Transfer Curriculum (IGETC); (3) any elective courses to complete a minimum of 60 units of CSU transferable coursework; (4) have an overall GPA of 2.0.

Required Core:

Select One:		Units
SOC 101 C	Introduction to Sociology or	3
SOC 101HC	Honors Intro to Sociology	(3)

List A:

Select Two:		Units
SOC 102 C	Social Problems	3
SOC 161 C	Probability and Statistics — Social Science or	4
PSY 161 C	Probability and Statistics — Social Science	(4)
PSY 202 C	Research Methods in Psychology	4

List B:

Select Two:		Units
Selection may include any course not selected from List A or any of the following.		
SOC 275 C	Marriage and Family	3
PSY 251 C	Social Psychology	3
SOC 292 C	Introduction to Criminology or	3
HUSR 292 C	Introduction to Criminology	(3)

List C:

Select One:		Units
Selection may include any course not selected from List A or List B or any of the following.		
SOC 120 C	Human Sexuality or	3
PSY 120 C	Human Sexuality	(3)
SOC 215 C	Parenting Skills or	3
PSY 215 C	Parenting Skills	(3)
SOC 225 C	Sociology of Women	3
SOC 237 C	Cross-Cultural Relationships or	3
PSY 237 C	Cross-Cultural Relationships	(3)
SOC 250 C	Sociology of Aging or	3
HUSR 250 C	Sociology of Aging	(3)
SOC 277 C	Sociology of Religion	3
PSY 101 C	Introduction to Psychology	3
GEOG 160 C	Cultural Geography	3
ANTH 102 C	Cultural Anthropology	3
Total Units		19–20

SOCIOLOGY TRANSFER PROGRAM

Students should consult a counselor or www.assist.org for lower division major requirements for most California public universities. (See the Standard Definitions section of the catalog for a description of ASSIST.) Students transferring to an independent college/university should consult the catalog of the individual school and a counselor for lower division major requirements.

Sociology (SOC)

SOC 101 C Introduction to Sociology 3 Units

Advisory: Eligibility for ENGL 100 C.

Term hours: 48–54 lecture. This course is an analysis of human relationships through a study of cultural origins, personality development, social interaction, community organization, collective behavior, institutional growth, social change, and social movements. Duplicate credit not granted for SOC 101HC. (UC/CSU, AA GE, CSU GE, IGETC)

SOC 101HC Honors Introduction to Sociology 3 Units

Advisory: Eligibility for ENGL 100 C.

Term hours: 48–54 lecture. This course is an enhanced version of Introduction to Sociology for honors students. This course is an analysis of human relationships through a study of cultural origins, personality development, social interaction, community organization, collective behavior, institutional growth, social change, and social movements. Duplicate credit not granted for SOC 101 C. (UC/CSU, AA GE, CSU GE, IGETC)

SOC 102 C Social Problems 3 Units

Advisory: Completion of SOC 101 C and eligibility for ENGL 100 C.

Term hours: 48–54 lecture. This course is an identification and analysis of selected contemporary social problems in American society and around the world. It includes problems of overpopulation, environmental destruction, war, race, poverty, sex inequality, aging, drug abuse, health, crime and violence. Alternative approaches to the resolution of these problems and identification of institutions and organizations involved in their resolution are emphasized. (UC/CSU, AA GE, CSU GE, IGETC)

SOC 120 C Human Sexuality 3 Units

Same as PSY 120 C.

Advisory: Eligibility for ENGL 100 C.

Term hours: 48–54 lecture. This course is an overview of the psychological, sociological and psychobiological aspects of human sexuality. The course takes an interdisciplinary approach dealing with the entire area of human sexual behavior viewed in the context of the total integrated personality. Duplicate credit not granted for PSY 120 C. (UC/CSU, CSU GE, AA GE, IGETC)

SOC 161 C Probability and Statistics: Social Sciences 4 Units

Same as PSY 161 C.

Prerequisite: MATH 040 C or Algebra II with a grade of "C" or better and the assessment process.

Term hours: 64–72 lecture. This course provides an introduction to fundamental statistical concepts relevant to the social sciences but applicable to all disciplines. A conceptual approach is used to introduce students to topics of descriptive and inferential statistics including sampling, probability, central tendency, variability, correlation, regression, point estimation, interval estimation, and hypothesis testing. Also introduced are non-parametric statistics, such as chi-square, and parametric statistics, such as t-tests and ANOVA. Computers and calculators will be utilized. The use of current statistical software is emphasized. Data sets and problems will be from psychology, sociology, anthropology, economics, geography, and political science. This course is open to all students who meet the prerequisite, and it is required for psychology majors. This course is strongly recommended for all social sciences majors. Students who receive credit for this course may not receive credit for MATH 120 C. Duplicate credit not granted for PSY 161 C, PSY 161HC, or SOC 161HC. (UC Credit Limitation/CSU, AA GE, CSU GE, IGETC)

SOC 161HC Honors Probability and Statistics: Social Sciences 4 Units

Same as PSY 161HC.

Prerequisite: Completion of or concurrent enrollment in MATH 040 C with a minimum grade of "C."

Term hours: 64–72 lecture. This honors course provides an introduction to fundamental statistical concepts relevant to the social sciences but applicable to all disciplines. A conceptual approach is used to introduce students to topics of descriptive and inferential statistics including sampling, probability, central tendency, variability, correlation, regression, point estimation, interval estimation, and hypothesis testing. Also introduced are non-parametric statistics, such as chi-square, and parametric statistics, such as t-tests and ANOVA. Computers and calculators will be utilized. The use of current statistical software is emphasized. Data sets and problems will be from psychology, sociology, anthropology, economics, geography, and political science. This course is open to all students who meet the prerequisite, and it is required for psychology majors. This course is strongly recommended for all social sciences majors. Students who receive credit for this course may not receive credit for MATH 120 C. Duplicate credit not granted for PSY 161 C, PSY 161HC, or SOC 161 C. (UC/CSU, AA GE, CSU GE, IGETC)

SOC 215 C Parenting Skills 3 Units

Same as PSY 215 C.

Term hours: 48–54 lecture. This course is designed to build realistic expectations in parenting. Students will acquire parenting skills and deal constructively with varied aspects of child rearing. A special emphasis will be placed on reviewing contemporary discipline and guidance techniques and on exploring resources available in the community for parenting. The course includes developmental stages from birth through adulthood. (CSU)

SOC 225 C Sociology of Women 3 Units

Advisory: Eligibility for ENGL 100 C.

Term hours: 48–54 lecture. This course covers an identification and analysis of the status of women in American society. Sociological issues pertinent to the conditions of women are examined, such as the social construction of gender, feminism, women's health, sexuality, relationships, employment, and familial roles. (UC/CSU, CSU GE, IGETC)

SOC 237 C Cross-Cultural Relationships 3 Units

Same as PSY 237 C.

Advisory: Eligibility for ENGL 100 C.

Term hours: 48–54 lecture. This course is an introduction to the psychological factors involved in cross-cultural relationships including ethnic and racial differences. It explores the personal processes and individual conflicts of people from differing United States ethnic backgrounds. Varying customs, social patterns and family dynamics of major local cultural groups will be discussed within this context. (UC/CSU, CSU GE, IGETC, CUL DIV)

SOC 250 C Sociology of Aging 3 Units

Same as HUSR 250 C.

Term hours: 48–54 lecture. This course explores the concept of aging and sociological/cultural theories of aging. The gender, cross-cultural, economic, political and social policy aspects of aging in society and the world are examined. Critical life issues for elders and for those who live and work with them are explored. These issues include empowerment, care giving, social support, living arrangements, elder abuse, work, retirement, quality of life and death and dying. Duplicate credit not granted for HUSR 250 C. (UC/CSU, AA GE, CSU GE, IGETC)

SOC 275 C Marriage and Family 3 Units

Advisory: Eligibility for ENGL 100 C.

Term hours: 48–54 lecture. This course is a study of the sociological factors involved in family relationships, courtship, marital adjustments and parenthood. This course examines various patterns of marriage and families within the United States. (UC/CSU, AA GE, CSU GE, IGETC)

SOC 277 C Sociology of Religion 3 Units

Advisory: Eligibility for ENGL 100 C.

Term hours: 48–54 lecture. This course is an analysis of religion as a social institution. Emphasis will be placed on the influence that religion has on American society by examining the role religion plays in people's lives, and legitimates some existing social and economic arrangements. (UC/CSU, CSU GE, IGETC)

SOC 292 C Introduction to Criminology 3 Units

Same as HUSR 292 C.

Term hours: 48–54 lecture. This course presents a scientific analysis of the nature, extent, and causes of violations of societal rules of behavior that are formally defined as crime and delinquency. The course includes an analysis of the theoretical perspectives that led to the development of criminal law and the administration of criminal justice, the patterns of criminality and delinquency, the impact of crime on social change, and the labeling, identification, characteristics, and the treatment of criminals and delinquents. Duplicate credit not granted for HUSR 292 C. (UC/CSU, CSU GE, IGETC)

SOC 298 C Sociology Seminar .5 to 12 Units

Prerequisite: May be required.

Corequisite: May be required.

Advisory: May be required.

Term hours: 0–216 lecture and/or 0–432 laboratory depending on units attempted. This is a lecture/discussion type course developed on a particular limited problem or topic of interest to students. It is designed for students who wish to increase their knowledge of a particular topic concerning which no other regular class is offered. A paper or group activity may be requested. Credit may range from .5 units to 12 units. Consult class schedule for the offerings a particular semester. May be taken for credit 1–4 times. Pass/No Pass or Pass/No Pass/Letter Grade Option or Standard Letter Grade. Fees may be required — Payable at Registration. (UC Credit Limitation/CSU)

SOC 299 C Sociology Independent Study 1 Unit

Prerequisite: Approved Independent Study Learning Contract.

Term hours: 16–18 lecture. Independent study is for students who wish to extend their knowledge of a particular area through individual research and study. It is thought that topics might develop out of a curiosity stimulated in a regular class. Students would then contact the supervising instructor to develop a learning contract for their particular interest so that they could learn more regarding their chosen specific topic. May be taken for credit 4 times. (UC Credit Limitation/CSU)

Spanish

Division of Language Arts

Division Dean — Eldon Young

Faculty

E. Alex Herrera

A. Fernando Oliveira

Jessica Puma

Counselors

Velia Lawson

Daniel Pelletier

Therese Mosqueda-Ponce

PROGRAM LEARNING OUTCOMES (PLOs)

The courses taught by this department contribute to the General Education and Basic Skills Program Learning Outcomes. Please refer to General Education and Basic Skills Program Learning Outcomes.

Spanish (SPAN)

SPAN 050 C Public Service Spanish 3 Units

Term hours: 48–54 lecture. This course is a basic communication course, for students who want to acquire a speaking knowledge for vocational needs in the fields of health-care, social welfare, law enforcement, hotel and restaurant industries, and business in general. Consideration also will be given to cultural topics. It is assumed that the student has no prior knowledge of the language. Pass/No Pass/Letter Grade Option.

SPAN 053 C Basic Spoken Spanish 3 Units

Term hours: 48–54 lecture. This is a basic introductory course which emphasizes oral practice, pronunciation and vocabulary development. It is designed to develop a speaking and understanding knowledge of Spanish for use in everyday conversational situations. It is not open to native speakers of the language. May be taken for credit 2 times. Pass/No Pass/Letter Grade Option.

SPAN 098 C Spanish Seminar .5 to 12 Units

Prerequisite: May be required.

Corequisite: May be required.

Advisory: May be required.

Term hours: 0–216 lecture and/or 0–432 laboratory depending on units attempted. This seminar is for able students who wish to extend their knowledge of literature, language and culture through small group discussion. May be taken for credit 1–4 times. Pass/No Pass or Pass/No Pass/Letter Grade Option or Standard Letter Grade. Fees may be required — Payable at Registration.

SPAN 101 C Elementary Spanish I 5 Units

Term hours: 80–90 lecture and 16–18 laboratory TBA. The course emphasizes the acquisition of basic skills in pronunciation, listening, speaking, reading, and writing. Students will be introduced to the culture, history, and geography of Spain and Latin America. Duplicate credit not granted for SPAN 101HC. Pass/No Pass/Letter Grade Option. (UC Credit Limitation/CSU, AA GE, CSU GE)

SPAN 101HC Honors Elementary Spanish I 5 Units

Term hours: 80–90 lecture and 16–18 laboratory TBA. This course offers an introduction to Elementary Spanish enhanced for Honors students in a seminar type setting. Students will acquire basic skills in pronunciation, listening, speaking, reading and writing. Students will be introduced to the culture, history, and geography of Spain and Latin America through lectures, slides, films, and reading assignments. Students will create original dialogues and current event discussions. Duplicate credit not granted for SPAN 101 C. (UC Credit Limitation/CSU, AA GE, CSU GE)

SPAN 102 C Elementary Spanish II 5 Units

Prerequisite: SPAN 101 C with grade of "C" or better, or one year of high school Spanish with a grade of "C" or better is recommended.

Term hours: 80–90 lecture and 16–18 laboratory TBA. The course continues to emphasize the acquisition of basic skills in pronunciation, listening, speaking, reading, and writing. Students will increase their knowledge of the culture, history, and geography of Spain and Latin America through lectures, slides, films, and reading and writing assignments. Duplicate credit not granted for SPAN 102HC. Pass/No Pass/Letter Grade Option. (UC Credit Limitation/CSU, AA GE, CSU GE, IGETC)

SPAN 102HC Honors Elementary Spanish II 5 Units

Prerequisite: SPAN 101 C with a grade of "C" or better, or one year of high school Spanish with a grade of "C" or better is recommended.

Term hours: 80–90 lecture and 16–18 laboratory TBA. This course is a continuation of elementary Spanish enhanced for honors students in a seminar setting. Students will create original dialogues and participate in current events discussions in order to increase their knowledge of the culture, history, and geography of Spain and Latin America. Lectures, slides, films, and reading and writing assignments will also be used. Duplicate credit not granted for SPAN 102 C. (UC Credit Limitation/CSU, AA GE, CSU GE, IGETC)

SPAN 200 C Conversational Spanish 2 Units

Prerequisite: SPAN 102 C.

Term hours: 32–36 lecture. The course emphasizes extensive practice in oral expression and listening comprehension at intermediate and advanced levels of competency. The materials used provide a systematic practice of grammatical concepts, literary analysis and cultural appreciation. May be taken for credit 4 times. Pass/No Pass/Letter Grade Option. (CSU, CSU GE)

SPAN 201 C Spanish for Spanish Speakers I 5 Units

Prerequisite: A native or near-native speaking knowledge of Spanish for those who have had little or no formal education in the language.

Term hours: 80–90 lecture. This course is designed to address the needs of students with Spanish speaking background who have little or no formal training in Spanish. Emphasis will be placed on composition, advanced reading comprehension, standard vs. vernacular usages, and cross-language interference. The course's aim is to reinforce oral expression and comprehension, develop writing skills, build a wider base vocabulary, read Hispanic literature and provide an awareness of the language. Pass/No Pass/Letter Grade Option. Duplicate credit not granted for SPAN 101 C/102 C. (UC Credit Limitation/CSU, AA GE, CSU GE, IGETC)

SPAN 202 C Spanish for Spanish Speakers II 5 Units

Prerequisite: SPAN 201 C.

Term hours: 80–90 lecture. This course is designed for students who are fluent in spoken, informal Spanish and who need to improve their writing, reading, and grammar skills. It furthers the mastery of formal, written communication in Spanish at the intermediate/advanced level while integrating in Hispanic, Latin American, and Chicano culture through increased practice in intermediate/advanced level readings. The course focuses on language challenges that Spanish speakers still encounter at the intermediate/advanced level, such as orthography, the inappropriate mix of English and Spanish in specific contexts, and standard Spanish as contrasted to regional variations. This course is conducted entirely in Spanish. Duplicate credit not given for SPAN 203 C. (UC Credit Limitation/CSU, AA GE, CSU GE, IGETC)

SPAN 203 C Intermediate Spanish III 4 Units

Prerequisite: SPAN 102 C with a grade of "C" or better, or two years of high school Spanish with a grade of "C" or better is recommended.

Term hours: 64–72 lecture and 16–18 laboratory TBA. The course introduces the student to the more formal aspects of literary analysis and cultural appreciation through a selection of readings by modern Spanish and Spanish American authors. It also provides extensive practice in oral and written expression and a thorough review of grammatical concepts. Pass/No Pass/Letter Grade Option. (UC/CSU, AA GE, CSU GE, IGETC)

SPAN 204 C Intermediate Spanish IV 4 Units

Prerequisite: SPAN 203 C with a grade of "C" or better, or three years of high school Spanish with a grade of "C" or better is recommended.

Term hours: 64–72 lecture and 16–18 laboratory TBA. The course continues to emphasize acquisition of the more formal aspects of literary analysis and cultural appreciation through a selection of advanced readings by modern Spanish and Spanish American authors. It also provides extensive practice in oral and written expression and a thorough review of grammatical concepts. Pass/No Pass/Letter Grade Option. (UC/CSU, AA GE, CSU GE, IGETC)

SPAN 298 C Spanish Seminar .5 to 12 Units

Prerequisite: May be required.

Corequisite: May be required.

Advisory: May be required.

Term hours: 0–216 lecture and/or 0–432 laboratory depending on units attempted. This seminar is for able students who wish to extend their knowledge of literature, language and culture through small group discussion. May be taken for credit 1–4 times. Pass/No Pass Or Pass/No Pass/Letter Grade Option or Standard Letter Grade. Fees may be required — Payable at Registration. (UC Credit Limitation/CSU)

SPAN 299 C Spanish Independent Study .5 to 2 Units

Prerequisite: Approved Independent Study Learning Contract.

Two hours conference per week for maximum credit. This course is designed for able students who wish to increase their knowledge of language through individual study or research. Variable Unit Class. May be taken for credit 3 times. Pass/No Pass/Letter Grade Option. (UC Credit Limitation/CSU)

SPANISH TRANSFER PROGRAM

Students should consult a counselor or www.assist.org for lower division major requirements for most California public universities. (See the Standard Definitions section of the catalog for a description of ASSIST.) Students transferring to an independent college/university should consult the catalog of the individual school and a counselor for lower division major requirements.

Speech

Now known as

Communication Studies

Theater Arts

Division of Fine Arts

Division Dean — Ting-Pi (Joyce) Carrigan

Faculty

James Hormel
Mark Majarian
Barbara Braden Meyer

Counselors

Renay Laguana-Ferinac
Renee Ssensalo

PROGRAM LEARNING OUTCOMES (PLOs)

Theater Department

- Given a performance or production setting, students will demonstrate their knowledge and comprehension of major theater practices and standards.
- Given a performance or production setting, students will use theatrical techniques to communicate to an audience.
- Given a performance or production setting, students will be able to analyze, evaluate and create production and performance elements.
- Given a performance or production setting, students will demonstrate their knowledge and ability to appreciate theater as an art form and their ability to collaborate with other theater practitioners as self defining artists.

ASSOCIATE IN ARTS DEGREE

THEATER ARTS **Program Code: 1A03779**

This program is designed to prepare the student with a fundamental understanding and acquisition of knowledge in the theater arts discipline. The curriculum includes courses in theater production and acting as well as performance and production experience.

To earn an Associate Degree students must complete: (1) all major course requirements with a minimum grade of "C"; (2) 25 units of General Education Graduation Requirements; (3) cultural diversity and reading requirements; (4) any elective courses to complete a minimum of 60 units; and, (5) have a minimum GPA of 2.0. At least 50% of all major course work must be completed at Cypress College.

Courses that fulfill major requirements for an Associate Degree at Cypress College might not be the same as those required for completing the major at a transfer institution offering a Baccalaureate Degree. For information on specific university requirements, please consult with your counselor, or visit the Transfer Center.

Required courses are listed in suggested sequence:

Course #	Title	Units
THEA 100 C	Introduction to the Theater	3
THEA 120 C	Acting I	3
THEA 143 C	Stagecraft	3
	or	
THEA 140 C	Introduction to Theater Design	(3)
THEA 124 C	Acting II	3
	or	
THEA 126 C	Musical Theater Techniques	(3)
THEA 144 C	Lighting Design Fundamentals	3
	Or	
THEA 146 C	Scene Painting	(3)
THEA 129 C	Voice and Diction	3
THEA 145 C	Fundamentals of Costume Design	3
	or	
THEA 147 C	Stage Makeup	(3)
THEA 107 C	Diversity in American Theater	3
	or	
THEA 107HC	Honors Diversity in AM Theater	(3)
THEA 220 C	Scene Study	3
	or	
THEA 226 C	Musical Theater Styles	(3)

Select 2–3 units from the following performance classes according to emphasis:

THEA 130 C	Acting Workshop	3
THEA 132 C	Musical Theater Workshop	2–3
THEA 133 C	Rehearsal and Performance	2–3
THEA 149 C	Stage Crew Activity	1,1,1
THEA 234 C	Ensemble Acting	2–3
MUS 290 C	Musical Theater Production	2–3
	Total Units	29–30

COSTUME/MAKEUP DESIGN CERTIFICATE

Program Code: 1K12955

The certificate in costume/makeup design is designed to prepare the student for occupational competency in the field of costume/makeup design for theater.

To earn a certificate, the required courses as listed with a minimum grade of "C." At least 50% of all course work must be completed at Cypress College.

Required courses are listed in suggested sequence:

Course #	Title	Units
THEA 145 C	Fundamentals of Costume Design	3
ART 185 C	Life Drawing	3
THEA 147 C	Stage Makeup	3
THEA 149 C	Stage Crew Activity	1,1,1

And an additional 3 units from the following:

(THEA 149 C may be taken for an additional 3 units if taken for two different production assignments.)

THEA 247 C	Prosthetic Makeup	3
THEA 149 C	Stage Crew Activity	1,1,1
	Total Units	15

**LIGHTING/AUDIO DESIGN
CERTIFICATE**

Program Code: 1K12956

This certificate in lighting/audio design is designed to prepare the student in occupational competency in lighting and sound design for theater.

To earn a certificate, the required courses must be completed as listed with a minimum grade of "C." At least 50% of all course work must be completed at Cypress College.

Required courses are listed in suggested sequence:

Course #	Title	Units
MUS 124 C	Recording Studio I or	3
THEA 142 C	Theater Sound and Recording	(2)
THEA 144 C	Lighting Design Fundamentals	3
THEA 149 C	Stage Crew Activity	1,1,1
*ART 182 C	Freehand Drawing	3
THEA 140 C	Introduction to Theater Design	3
Total Units		13–15

*A score of 3 or higher on the Advanced Placement (AP) Art (Studio Drawing) exam meets this requirement upon petition through Admissions and Records. See a counselor for more information.

**TECHNICAL THEATER
CERTIFICATE**

Program Code: 1K12962

The Technical Theater Certificate is designed to prepare the student for occupational competency in the field of technical theater.

To earn a certificate, the required courses as listed with a minimum grade of "C." At least 50% of all course work must be completed at Cypress College.

Required courses are listed in suggested sequence:

Course #	Title	Units
THEA 140 C	Introduction to Theater Design	3
*ART 182 C	Freehand Drawing	3
THEA 120 C	Acting I	3
THEA 149 C	Stage Crew Activity	1,1,1
THEA 143 C	Stagecraft	3
Total Units		14–15

*A score of 3 or higher on the Advanced Placement (AP) Art (Studio Drawing) exam meets this requirement upon petition through Admissions and Records. See a counselor for more information.

THEATER ARTS TRANSFER PROGRAM

Students should consult a counselor or www.assist.org for lower division major requirements for most California public universities. (See the Standard Definitions section of the catalog for a description of ASSIST.) Students transferring to an independent college/university should consult the catalog of the individual school and a counselor for lower division major requirements.

Theater Arts (THEA)

THEA 100 C Introduction to the Theater 3 Units

Term hours: 48–54 lecture. This course is designed for those who wish to explore the arts with special attention given to a survey of all the contributing elements. The course prepares the student for other course offerings in the theater curriculum. Pass/No Pass/Letter Grade Option. Admission to theater performance not to exceed \$50.00. (UC/CSU, AA GE, CSU GE, IGETC)

THEA 107 C Diversity in American Theater 3 Units

Advisory: Eligibility for ENGL 100 C.
Term hours: 48–54 lecture. America's ethnic, racial and cultural heritages and the struggles for social equality that have shaped American theater, literature and performance will be explored. Duplicate credit not given for THEA 107HC. Admission to theater performance not to exceed \$50.00. (UC Credit Limitation/CSU, AA GE, CSU GE, IGETC, CUL DIV)

THEA 107HC Honors Diversity in American Theater 3 Units

Advisory: Eligibility for ENGL 100 C.
Term hours: 48–54 lecture. This course is an enhanced study of America's ethnic, racial and cultural heritages and the struggles for social equality that have shaped American theater, literature and performance. Duplicate credit not given for THEA 107 C. Admission to theater performance not to exceed \$50.00. (UC Credit Limitation/CSU, AA/AS, CSU GE, IGETC, CUL DIV)

THEA 108 C Stage and Screenwriting 3 Units

Advisory: Eligibility for ENGL 100 C.
Term hours: 48–54 lecture. Beginning playwrights and screenwriters discover the basic craft of creating scripts for stage, screen and television. The class will concentrate on student's current work and illustrations will be drawn from contemporary plays and screenplays. May be taken for credit 4 times. (CSU, AA GE, CSU GE)

THEA 120 C Acting I 3 Units

Term hours: 32–36 lecture and 64–72 laboratory. Acting methods of the modern actor will be studied. Students will use craft preparations which will enable them to bring emotional and behavioral truth to the roles they create. Exercises in relaxation, sensory awareness, emotional freedom and the creation of truthful behavior will be practiced. Admission to theater performances not to exceed \$50.00. Pass/No Pass/Letter Grade Option. (UC/CSU, AA GE, CSU GE)

THEA 121 C Dynamic Movement for the Stage 2 Units

Term hours: 16–18 lecture and 48–54 laboratory. Students learn the art of physical communication. Students will discover and explore structured physical play, unarmed stage combat and stimulus response exercises. Basic anatomy as it relates to motion and communication will be examined. This class is designed for actors and all students. May be taken for credit 2 times. (UC/CSU, CSU GE)

THEA 124 C Acting II 3 Units

Prerequisite: THEA 120 C or audition.
Advisory: Concurrent enrollment or completion of THEA 121 C or THEA 129 C.
Term hours: 32–36 lecture and 64–72 laboratory. Actors will proceed to a more advanced exploration and mastery of the basic craft of acting. Actors will learn specific skills for preparing a role and for creating and experiencing the imaginary realities that fulfill a script. May be taken for credit 3 times. Admission to theater performances not to exceed \$50.00. (UC/CSU)

THEA 126 C Musical Theater Techniques 3 Units

Term hours: 32–36 lecture and 64–72 laboratory. Students will investigate performance methods of musical theater as they relate to the onstage performer. All styles of musical theater may be covered and performance in a workshop setting of musical theater literature is required. Admission to theater performances not to exceed \$50.00. May be taken for credit 4 times. (UC/CSU, AA GE, CSU GE)

THEA 128 C Acting for the Camera 2 Units

Term hours: 16–18 lecture and 48–54 laboratory. Students will master the fundamental craft of acting for television and feature film. Guidelines for solving the specific demands the camera makes on the actor will be stressed. Pass/No Pass/Letter Grade Option. (UC/CSU)

THEA 129 C Voice and Diction 3 Units

Term hours: 48–54 lecture. This is a course in the study of and exercise in voice production and articulation with the goal of producing Standard American speech. Special attention is given to diction for actors, classroom teachers and students with minor speech defects. Stress is placed on individual exercises designed to give conscious control of speech functions. Attendance at theater productions may be required. May be taken for credit 2 times. Pass/No Pass/Letter Grade Option. (UC/CSU, AA GE, CSU GE)

THEA 130 C Acting Workshop 3 Units

Prerequisite: Audition.

Term hours: 48–54 lecture and 96–108 laboratory TBA. This performance laboratory will emphasize the application of the principles and the craft of creative acting. Faculty and theater students will initiate and prepare performance projects for an invited audience. These projects will emphasize the performers with a limited use of production elements. May be taken for credit 4 times. (UC/CSU)

THEA 132 C Musical Theater Workshop 2 to 3 Units

Prerequisite: Audition.

Advisory: Concurrent enrollment in one of the following: DANC 203 C, THEA 149 C, or one from THEA 140 C through THEA 147 C.

Term hours: 128–216 laboratory TBA depending on units attempted. The student will participate in the preparation of a musical production through acting, singing, dancing and/or instrumental accompaniment. Performers will make use of production elements and performance techniques. May be taken for credit 4 times. (UC/CSU, AA GE, CSU GE)

THEA 133 C Rehearsal and Performance 2 to 3 Units

Prerequisite: Audition.

Advisory: Concurrent enrollment in one of the following: DANC 203 C, THEA 149 C, or one from THEA 140 C through THEA 147 C.

Term hours: 128–216 laboratory TBA depending on units attempted. This course teaches the practical application of acting and production techniques, i.e., acting, stage managing, backstage operation. Students will participate in the rehearsal and performance of a public production occurring in the Theater Arts Department. May be taken for credit 4 times. (UC/CSU, AA GE, CSU GE)

THEA 134 C Auditions for Theater/Film 1 Unit

Prerequisite: Audition.

Term hours: 16–18 lecture. Theater students will create and then perform audition presentations that demonstrate their proficiency in the fundamental skills of acting and auditioning. May be taken for credit 3 times. (CSU)

THEA 140 C Introduction to Theater Design 3 Units

Term hours: 32–36 lecture and 64–72 laboratory. Students will be offered a survey of scenery, lighting, sound, costumes, makeup, properties, theatrical equipment, and construction techniques through demonstration, and laboratory experience. Information is applicable to all formal theatrical applications. Admission to theater performance not to exceed \$50.00 (UC/CSU)

THEA 142 C Theater Sound and Recording 2 Units

Term hours: 16–18 lecture and 48–54 laboratory. The student will be involved in recording studio procedure and equipment selection and use for theater. The course covers the technical as well as the artistic use of sound recording for theater. Emphasis will be placed on the practical use of audio equipment. Admission to theater performances will not exceed \$50. May be taken for credit 2 times. (CSU)

THEA 143 C Stagecraft 3 Units

Term hours: 32–36 lecture and 48–54 laboratory. This course explores the planning and execution of scenic elements for the stage with an emphasis on design, construction and methods of shifting scenery. Admission to theater performances will not exceed \$50.00. May be taken for credit 2 times. \$25 Materials Fee — Payable at Registration. (UC/CSU)

THEA 144 C Lighting Design Fundamentals 3 Units

Term hours: 32–36 lecture and 48–54 laboratory. This course involves the study and execution of stage lighting with emphasis on equipment, control, color, and their relationship to design. Admission to theater performances not to exceed \$50. May be taken for credit 2 times. (UC/CSU)

THEA 145 C Fundamentals of Costume Design 3 Units

Term hours: 32–36 lecture and 48–54 laboratory. Students will study costume history, design, and basic construction techniques as an introduction to basic theatrical costuming. Fabrics and their various uses will be investigated. May be taken for credit 2 times. Admission to theater performances will not exceed \$50. (UC/CSU, CSU GE)

THEA 146 C Scene Painting 3 Units

Term hours: 32–36 lecture and 48–54 laboratory. Various methods of painting theatrical scenery will be explored. Tools to be used will include brush, roller, sponges. Students will duplicate stucco, masonry, wood-grain, foliage, wallpaper, lettering, drapery, and architectural detail on rigid scenery. May be taken for credit 3 times. Admission to the theater performances will not exceed \$50.00. \$25.00 Materials Fee — Payable at Registration. (UC/CSU)

THEA 147 C Stage Makeup 3 Units

Term hours: 32–36 lecture and 48–54 laboratory. Students will receive instruction and practice in a lecture/laboratory setting in all phases of makeup specifically designed for theatrical use. May be taken for credit 2 times. Admission to theater performances not to exceed \$50. (UC/CSU)

THEA 148 C Production Techniques .5 to 12 Units

Prerequisite: Involvement in the production program.

Term hours: 32–864 depending on units attempted. This is an open entry/open exit class for students to obtain production experience in theater and dance through acting, directing, production, management and publicity. May be taken for credit 4 times. Open Entry/Open Exit. (CSU)

THEA 149 C Stage Crew Activity 1 to 2 Units

Term hours: 64–144 laboratory TBA. Stage crew offers practical experience in stage management scenery, paint, sound, props, lighting, makeup and costumes through preparation of a play for public performance. May be taken for credit 4 times. (UC/CSU, AA GE, CSU GE)

THEA 220 C Scene Study 3 Units

Prerequisite: THEA 120 C with a minimum grade of "C."

Advisory: THEA 121 C or THEA 129 C.

Term hours: 32–36 lecture and 64–72 laboratory. The actor will examine and practice the fundamental skills required to perform in historical and stylized dramatic works. The reading and performance of dramatic literature that varies from classical texts to avant-grade works and non-traditional sources are required. May be taken for credit 2 times. Admission to theater performances not to exceed \$50.00. (UC/CSU)

THEA 225 C Directing for the Theater 3 Units

Advisory: ENGL 060 C.

Term hours: 32–36 lecture and 64–72 laboratory. The director's purpose in the theater will be examined through current craft approaches and through a historical context. Practical experience in directing through class projects will be stressed. May be taken for credit 3 times. Admission to theater performances not to exceed \$50.00. (UC/CSU)

THEA 226 C Musical Theater Styles 3 Units

Prerequisite: Audition.

Term hours: 32–36 lecture and 64–72 laboratory. Students will explore scene work and audition techniques for musical theater. This course is designed for the performance oriented student. May be taken for credit 4 times. Admission to theater performances not to exceed \$50.00. (CSU)

THEA 228 C Advanced Acting for the Camera 2 Units*Prerequisite: THEA 128 C or audition.*

Term hours: 16–18 lecture and 48–54 laboratory. Students will continue their exploration and mastery of craft approaches for television and film acting, including, but not limited to advanced character development and special problems in performance preparation. May be taken for credit 3 times. Pass/No Pass/Letter Grade Option. (CSU)

THEA 230 C Directing Actors for Film/TV 2 Units

Term hours: 16–18 lecture and 48–54 laboratory. Student directors will analyze screenplays and characters for the purpose of directing actors. Emphasis on staging scenes for the camera to elicit the best possible performances from the actors. May be taken for credit 4 times. (UC/CSU)

THEA 232 C Musical Theater Production 2 to 3 Units*Prerequisite: Audition.*

Term hours: 128–216 laboratory TBA depending on units attempted. The students will prepare a work of musical theater for public performance through play analysis, character analysis, style analysis and rehearsal using vocal skills, choreographic movement and acting techniques. May be taken for credit 4 times. (CSU)

THEA 234 C Ensemble Acting 2 to 3 Units*Prerequisite: Audition.*

Advisory: Concurrent enrollment in one of the following: DANC 203 C, THEA 149 C or one from THEA 140 C through THEA 147 C.

Term hours: 128–216 laboratory depending on units attempted. This is a performance oriented course that concentrates on training students in the methodology and advanced skills of ensemble acting during a rehearsal period. Production support in the areas of stage management, backstage operations, sound, makeup, costumes, and house management are also introduced by practical involvement in the unique demands of producing an ensemble performance. May be taken for credit 4 times. (UC/CSU)

THEA 235 C Experimental Theater 2 Units

Term hours: 96–108 laboratory. This course consists of short-term projects in theater production (selection to be made by the department). Projects may include student-directed, one act plays, touring shows and improvisational theater shows. May be taken for credit 4 times. (UC/CSU)

THEA 247 C Prosthetic Makeup 3 Units*Prerequisite: THEA 147 C.*

Term hours: 32–36 lecture and 48–54 laboratory. Students will explore the techniques of special effects makeup. The basic construction of foam latex appliances, wounds and burns, bald cap application, and ventilated hair construction will be utilized. May be taken for credit 3 times. \$150 Materials Fee — Payable at Registration. (CSU)

THEA 298 C Theater Arts Seminar .5 to 12 Units*Prerequisite: May be required.**Corequisite: May be required.**Advisory: May be required.*

Term hours: 0–216 lecture and/or 0–864 laboratory depending on units attempted. Various classes may be offered from semester to semester which are designed to meet the interests and needs of the students. May be taken for credit 1–4 times. Pass/No Pass or Pass/No Pass/Letter Grade Option or Standard Letter Grade. Fees may be required — Payable at Registration or for admission to theater performances. (UC Credit Limitation/CSU)

THEA 299 C Theater Arts — Independent Study .5 to 2 Units*Prerequisite: Approved Independent Study Learning Contract.*

Term hours: 8–36 lecture depending on units attempted. This course is designed for students who wish to increase their knowledge of theater and/or theatrical practices through individual study or research. May be taken for credit 4 times. (UC Credit Limitation/CSU)

Travel Careers — See Airline and Travel Careers (ATC)

Undeclared or Undecided

TRANSFER PROGRAM

Students should consult a counselor or www.assist.org for lower division major requirements for most California public universities. (See the Standard Definitions section of the catalog for a description of ASSIST.) Students transferring to an independent college/university should consult the catalog of the individual school and a counselor for lower division major requirements.

Veterinary Medicine

VETERINARY MEDICINE TRANSFER PROGRAM

Professional programs such as dentistry, medicine, pharmacy, optometry, physician assistant, physical therapy and veterinary medicine are most often graduate programs that require a bachelor degree or significant preparation prior to entering the program. The appropriate preparation varies according to the school and specific program. Students are advised to meet with a counselor to discuss options for their bachelor degree and the lower division requirements for the program and school of their choice.

Welding

Division of Career Technical Education

Division Dean — Steve Donley

Counselor
Jane Jepson

Welding (WELD)

WELD 040 C Material Fabrication Machining 4 Units

Term hours: 32–36 lecture and 96–108 laboratory. This is a course designed to prepare the student with skills in machine tool equipment used by industry. Students will be instructed in the use of the lathe, drill press, grinder, shaper, milling machine and measuring instruments. Machine and sheet metal fabrication will prepare the student in the use of metals in the joining, forming, shaping and cutting of materials. Material fees for materials provided by the Department. May be taken for credit 2 times. Fee is paid in the Bookstore as needed during the semester.

WELD 060 C Welding/Metal Fabrication**3 Units***Prerequisite: Previous welding experience.*

Term hours: 32–36 lecture and 96–108 laboratory. This course includes the fundamentals and theory of oxyacetylene and metallic arc welding, with practical application to joint preparation and fabrication. Selection and use of additive electrodes to ferrous and non-ferrous metals are included. May be taken for credit 4 times. Laboratory fees for materials provided by the Department. Fee is paid in the Bookstore as needed during the semester.

WELD 298 C Welding Seminar**.5 to 12 Units***Prerequisite: May be required.**Corequisite: May be required.**Advisory: May be required.*

Term hours: 0–216 lecture and/or 0–864 laboratory depending on units attempted. This is a course for students who wish to increase their knowledge of welding. Various topics will be offered. Unit credit may range from .5 units to 12 units in any given semester. Consult the class schedule to verify credit for a particular semester. May be taken for credit 1–4 times. Pass/No Pass or Pass/No Pass/Letter Grade Option or Standard Letter Grade. Fees may be required — Payable at Registration. (CSU)

Word Processing**See Computer Information Systems (CIS)**

Work Experience

**Division of Business and
Computer Information Systems***Division Dean* — Dave Wassenaar*Counselor*

Robert Grantham

Work Experience (WKEX)

WKEX 092 C Work Experience General**1 to 3 Units***Prerequisite: Must be enrolled in seven units, including work experience.*

Term hours: 16–18 lecture and 90 minimum hours employment in a business-related occupation. This course is designed to provide instruction and general advisement related to actual work experience. For the employed student who has either not yet declared a major or whose employment and major are not related. Students must carry a minimum of seven units, which may include Work Experience. Students may enroll up to a maximum of three semesters, earning up to 9 units of credit. May be taken for credit 3 times.

WKEX 191 C Work Experience — Vocational**1 to 4 Units***Prerequisite: Must be enrolled in seven units, including work experience.*

Term hours: 16–18 lecture and 90 minimum hours employment in a business-related occupation. This course is designed to provide instruction and general advisement related to actual work experience. Employment and major must be related. Students must carry a minimum of seven units, which may include Work Experience, and be appropriately declared a business major. Students may enroll up to a maximum of four semesters, earning up to 16 units of credit. May be taken for credit 4 times. (CSU)

Faculty

North Orange County Community College District

1830 W. Romneya
Anaheim, California 92801
(714) 578-8400

Board of Trustees

Jeffrey P. Brown

Barbara Dunsheath

Leonard L. Lahtinen

Michael B. Matsuda

Molly McClanahan

Donna Miller

M. Tony Ontiveros

Cypress College Student Trustee

Alie McCaskill

Fullerton College Student Trustee

Gabael Botello

District Administration

Chancellor

Ned Doffoney, Ed.D.

Vice Chancellor, Human Resources

Jeff Horsley

Vice Chancellor, Finance and Facilities

Fred Williams

Provost, School of Continuing Education

Greg Schultz

Cypress College Administration and Organizational Structure

PRESIDENT

Dr. Robert Simpson

Executive Vice President

Vacant

Vice President

Karen Cant

Executive Director, Foundation and
Community Relations

Raul Alvarez

Director, Institutional Research and
Planning

Dr. Santanu Bandyopadhyay

President

Executive Vice President

Administrative Services

Institutional Research and Planning

Foundation and Community Relations

Staff Development

Campus Diversity

Executive Vice President

**Educational Programs and
Student Support Services —**

**Business/CIS and Admissions and Records —
Dave Wassenaar, Dean**

Admissions and Records

Registrar — Regina Ford

Career Technical Education — Steve Donley, Dean

Distance Education/Online

Economic Development

Grants

Instructional Development

Title V

Perkins

Distance Education/Online Enrollment Management

Counseling and Student Development —

Paul R. de Dios, Dean

Adult Re-Entry Program

Articulation

Assessment Center

Career Planning Center

Counseling Center

Disabled Students Program and Services —

Dr. Kimberly Bartlett, Director

International Students Program — Yongmi Han, Manager

Legacy Program (Counseling Component)

Matriculation — Kristine Nelson, Manager

Puente Program (Counseling Component)

Student Discipline

Teacher Preparation Program (Counseling Component)

Transfer Center

Fine Arts — Ting-Pi Joyce Carrigan, Dean

Patrons of the Arts

Study Abroad

Health Sciences — John Sciacca

Health Services — Marla McBride, Director

Nursing — Darlene Fishman, Director

Language Arts — Eldon Young, Dean

Forensics
 Legacy Program
 Puente Program (Academic and Instructional Component)

Library and Learning Resources — Eldon Young, Dean**Physical Education and Athletics Director — Diane Henry, Dean**

Petitions
 Student Activities

Science, Engineering and Math — Richard Fee, Dean

Basic Skills
 Learning Communities

Social Sciences — Nina DeMarkey, Dean

Honors/Service Learning
 Teacher Preparation Programs (Academic Component)

Student Support Services — Dr. Richard Rams, Dean

CalWORKS
 CARE
 Extended Opportunity Programs and Services —
 Gilbert Contreras, Manager
 Financial Aid — Keith Cobb, Director
 Outreach and Recruitment
 TRAC
 Student Ambassadors

**Vice President — Karen Cant
 Administrative Services —****Academic Computing — Mike Kavanaugh, Manager**

Media Services

Bookstore — David Okawa, Manager**Campus Accounting — Dao Do, Manager****Campus Safety — Dr. Shirley L. Smith, Director**

Switchboard

Facilities Use and Rentals**Financial and Business Support Services****Food Services****Mailroom****Personnel****Physical Plant and Facilities — Albert Miranda, Director**

Maintenance and Operations — José Recinos, Manager

Production Center**Foundation and Community Relations — Raul Alvarez,
 Executive Director**

Public Information Officer — Marc Posner

Division Structure

Division Dean, Business and Computer Information Systems

Dave Wassenaar

Department Coordinator,
 Accounting and Real Estate

Jeanne Miller

Department Coordinator,
 Court Reporting

Carolee Freer

Department Coordinator,
 Computer Information Systems

Jesse Saldana

Department Coordinator,
 Management/Marketing/Sales/Retailing

Patricia Kishel

Department Coordinator, Computer Information
 Systems/Office Administration

Alireza Moady

Division Dean, Career Technical Education

Steve Donley

Department Coordinator,
 Airline and Travel Careers

Kathleen Reiland

Department Coordinator, Aviation

Kathleen Reiland

Department Coordinator,
 Air Conditioning/Refrigeration

Richard Hock

Department Coordinator,
 Automotive Collision

Dan Snook

Department Coordinator,
 Automotive Technology

John Alexander

Department Coordinator,
 Hospitality, Restaurant, Culinary Arts

Jeremy Peters

Department Coordinator,
 Marine Service

John Alexander

Division Dean, Counseling and Student Development

Paul R. de Dios

Director, Disabled Students
 Program and Services (DSP&S)

Dr. Kimberly Bartlett

Director, Transfer Center/
 Honors Counselor

Penny Gabourie

Manager, International Students Program

Yongmi Han

Manager, Matriculation

Kristine Nelson

Articulation Officer

Stacey Howard

Coordinator, Career Center

Deann Burch

Department Coordinator, Counseling

Velia Lawson

Counselor, Athletics/Physical Education

Dana Bedard

Counselor, Business and Computer Information
 Systems, and Veterans Affairs

Robert Grantham

Counselor, Career Technical Education

Jane Jepson

Counselor, Career Planning/
 Adult Re-Entry Program

Counselor, DSP&S Deborah Michelle
 Counselor, Fine Arts/
 International Students Program Renay Laguana-Ferinac
 Counselor, Fine Arts/Legacy Program Renee Ssensalo
 Counselor, Health Science Kelly Carter
 Denise Vo

Counselor, Language Arts, Social Science
 and Teacher Preparation Program Velia Lawson
 Counselor, Language Arts, Social Science
 and Puente Program Dr. Therese Mosqueda-Ponce
 Counselor, Language Arts/Social Science Daniel Pelletier
 Counselor, Science/Engineering/Mathematics
 Learning Disabilities Specialist, DSP&S Deidre Porter

Division Dean, Fine Arts Ting-Pi Joyce Carrigan
 Department Coordinator, Art Joyce Patti
 Department Coordinator,
 Communications/Journalism Robert R. Mercer
 Department Coordinator,
 Media Arts Design Ian Holmes
 Department Coordinator, Music Joe Gallo
 Department Coordinator, Photography Robert Johnson
 Department Coordinator, Theater/Dance Jim Hormel

Division Dean, Health Science John Sciacca
 Director of Nursing Darlene Fishman
 Department Coordinator,
 Dental Assisting Elizabeth Pacheco
 Department Coordinator,
 Dental Hygiene Carol Green
 Department Coordinator,
 Diagnostic Medical Sonography Lynn Mitts
 Department Coordinator,
 Health Information Technology Rosalie Majid
 Department Coordinator,
 Mortuary Science Glenn Bower
 Department Coordinator,
 Psychiatric Technology Jaime Ramos
 Department Coordinator,
 Radiologic Technology Lynn Mitts
 Department Co-Coordinators,
 Nursing Carole Harvey
 Anne Herzog

Division Dean, Language Arts Eldon Young
 Department Coordinator, English Randa Wahbe
 Department Coordinator,
 English as a Second Language Kathy Wada
 Department Coordinator,
 Foreign Language Alex Herrera
 Department Coordinator, Reading Sarah Jones
 Department Coordinator, Communication Studies Liana Koeppel

**Division Dean, Library and
 Learning Resource Center** Eldon Young
 Library Department Coordinator Peggy Austin
 Library Services Coordinator James Carrocino
 Learning Center Coordinator Virginia Derakhshanian

Division Dean, Physical Education Diane Henry
 Athletic Director Diane Henry
 Assistant Athletic Director Bill Pinkham
 Department Coordinator Margaret Mohr

**Division Dean, Science/Engineering/
 Mathematics** Richard Fee
 Department Coordinator, Biology Stephanie Spooner
 Department Coordinator, Chemistry Allison Gotoh
 Department Coordinator, Mathematics Sylvia Paek
 Department Coordinator,
 Physical Science, Computer Science Ron Armale

Division Dean, Social Sciences Nina DeMarkey
 Director of Human Services Virgil Adams III
 Department Coordinator, Anthropology Becky Floyd
 Department Coordinator, Economics Parwinder Sidhu
 Department Coordinator, Ethnic Studies Daniel Lind
 Department Coordinator, Geography Armando Mendoza
 Department Coordinator, History David Halahmy
 Department Coordinator,
 Philosophy and Religious Studies vacant
 Department Coordinator, Political Science Gloria Badal
 Department Coordinator, Psychology Brandy Young
 Department Coordinator, Sociology Larry Curiel

Instructional Divisions

Divisional faculty members and counselors have offices conveniently located adjacent to classrooms. In addition, each building provides lounge and study areas to encourage student participation in divisional activities.

Business and Computer Information Systems

BUSINESS EDUCATION BUILDING

The Business Division and Instructor offices are located on the second floor adjacent to Parking Lot 1. The building has three floors of instructional classrooms as well as a second floor Computer Information Systems Lab. Lobby areas on the first and second floors provide study areas and WiFi access.

PROGRAMS

Business Transfer Degrees, Business Vocational Certificates, Associate Business Degrees, Accounting, Computer Information Systems, Court Reporting, Real Estate, Marketing, and Management.

COUNSELOR

Grantham, Robert

DIVISION DEAN

Wassenaar, Dave

FACULTY

Dellinger, Patricia
Freer, Carolee
Izadi, Behzad
Jianto, Susana
Kishel, Patricia
Miller, Jeanne
Moody, Alireza
McKnight, Richard
Pelachik, Patricia
Saldana, Jesse
Woo, Donna
Wu, Penn

Career Technical Education

PROGRAMS

Administration of Justice, Air Conditioning and Refrigeration, Airline and Travel Careers, Automotive Collision Repair, Automotive Technology, Aviation — Commercial Pilot; Aviation — Management, Homeland Security, Hotel, Restaurant, Culinary Arts, Industrial Arts — Teaching, Marine Service Technician

COUNSELOR

Jepson, Jane

DIVISION DEAN

Donley, Steve

FACULTY

Alexander, John
Bacarella, Russell
Beard, Michael
Clark, Lisa
Hock, Richard
Klyde, Michael
Orozco, Luciano
Peters, Jeremy
Ramos, Larry
Reiland, Kathleen
Rosati, Stephanie
Sallade, Douglas
Snook, Dan
Urquidi, Carlos

Fine Arts

PROGRAMS

Art, Communications/Journalism, Dance, Media Arts Design, Music, Photography, Theater Arts

COUNSELORS

Laguana-Ferinac, Renay
Ssensalo, Renee

DIVISION DEAN

Carrigan, Ting-Pi Joyce

FACULTY

Beyer, George
DeCoro, Helena
Gallo, Joseph
Giardina, Edward
Haddad, Maha Afra
Holmes, Ian
Hormel, James
Jaffray, Sarah
Johnson, Michael
Johnson, Robert
Landry, Erin
Lester, Clifford
Majarian, Mark
Mercer, Robert
Meyer, Barbara Braden
Paiement, Paul
Patti, Joyce
Reid, Kathryn
Schulps, Molly

Health Science

PROGRAMS

Registered Dental Assistant
 Dental Hygiene
 Diagnostic Medical Sonography
 Diagnostic Medical Sonography Certificate
 Health Information Technology
 Health Information Coding
 Medical Staff Services Management
 Mortuary Science
 Registered Nursing
 Career Mobility Nursing
 Psychiatric Technician
 Radiologic Technology
 Imaging Technologist Assistant Certificate

COUNSELORS

Carter, Kelly
 Vo, Denise

DIVISION DEAN

Sciacca, John

DIRECTOR OF NURSING

Darlene Fishman

FACULTY

Ashburn, Shirley
 Blilie, Jeannie
 Boettger, Kathleen
 Bower, Glenn
 Boyce, Jane
 Contreras, Kendra
 Corrales, Nancy
 Faraci, Michael
 Franks, Joseph
 Frianeza, Michael
 Frumkin, Sally
 Gomez, Rebecca
 Grande, Jolena
 Green, Carol
 Greico, Laura
 Harvey, Carol
 Herzog, Anna
 Johannsen, Christina
 Kruse, Kathleen
 Lawrence, Roberta
 Majid, Rosalie
 Marquardt, Marcus
 McCament, David
 McNay, Sally
 Medina-Bernstein, Denise
 Mitts, Lynn
 Pacheco, Elizabeth
 Putman, Elizabeth
 Ramos, Jaime
 Rios-Miranda, Noemi
 Swytak, Judy

Valencia, Wendy
 Walker, Jane
 Williams, Marredda
 Winckler, Janet
 Zakala, Carol

Language Arts

PROGRAMS

English, ESL (English for Non-Native Speakers), Foreign Language, Communication Studies

COUNSELORS

Lawson, Velia
 Mosqueda-Ponce, Therese
 Pelletier, Daniel

DIVISION DEAN

Young, Eldon

FACULTY

Borla, Linda
 Brydges, Michael
 Chi, Hong
 Daniels, Joan C
 Deutsch, Nancy
 Dickey, Cherie
 Diep, Christie
 Forman, Mary K.
 Franklin, Cathy
 Fujimoto, Janet
 Ganer, Patricia
 Gutierrez, Ruth
 Herrera, E. Alexis
 Jones, Sarah
 Kashi, Barbara
 Keel, Lawrence J.
 Klein, S. Margaret
 Koeppel, Liana
 Lambros, John
 Llanos, Kathy
 Marshall, Barbara
 McAlister, Kathleen
 McPherson, Debra
 Melodia, Joseph
 Nabahani, Melanie
 Oliveira, Fernando
 Payne, John
 Puma, Jessica
 Robertson, Alison
 Rosenberg, Stuart
 Sonne, Kathryn
 Takahashi, K. Mariye
 Talwar, Ambika
 Vescial, Keith
 Wada, Kathryn
 Wahbe, Randa

Library and Learning Resources

PROGRAMS

Library, Learning and Academic Resources

COUNSELORS

Lawson, Velia
Mosqueda-Ponce, Therese
Pelletier, Daniel

DIVISION DEAN

Young, Eldon

FACULTY

Austin, Peggy
Doman, Monica
Pashaie, Billy
Peacock, Joyce

Physical Education

PROGRAMS

Physical Education — Teaching, Recreation

COUNSELOR

Bedard, Dana

DIVISION DEAN

Henry, Diane

FACULTY

Beidler, Larry
Bottiaux, Paul
Mohr, Margaret
Pickler, Brad
Pickler, Scott
Pinkham, Bill
Welliver, Nancy

Science/Engineering/Mathematics

PROGRAMS

Astronomy, Biological Sciences/Life Sciences, Biology, Chemistry, Computer Science, Physical Science, Engineering — Chemical, Civil, Electrical, Mechanical, Engineering Technology, Forestry, Geology, Industrial Technology, Mathematics, Physical Therapy, Physics, Pre-Dentistry, Pre-Medicine, Pre-Optometry, Pre-Pharmacy, Pre-Veterinary, Science Teacher Preparation

COUNSELOR

Porter, Deidre

DIVISION DEAN

Fee, Richard

FACULTY

Armale, Ron
Castle, Victoria
Chiplunkar, Sujata
Coopman, Jennifer
De Roo, Robin
Eckenrode, Adam
Frey, Michael
Gill, David
Gober, Joel
Godshalk, Kathryn
Gotoh, Allison
Ledesma, Nicole
Lee, Eunju
Landis, Lenore
Mao, Chaolin
Mintzer, Alex
Morvan, Laurie
Mottershead, Allen
Nusbaum, David
Ogoshi, Fumio
Paek, Sylvia
Palmisano, Michelle
Plett, Christina
Rajab, Adel
Sanchez, Tony
Sato, Dee Ann
Shrout, Cynthia
Spooner, Stephanie
Subramaniam, Brinda
Tomooka, Craig

Social Sciences

PROGRAMS

Alcohol and Drug Studies, Anthropology, Conflict Resolution, Criminal Justice, Economics, Ethnic Studies, Family Studies — Basic and Advanced, Geographic Information Systems, Geography, Gerontology, History, Human Services Generalist, Philosophy and Religious Studies, Political Science, Psychology, Sociology, Victimology

COUNSELORS

Lawson, Velia
Mosqueda-Ponce, Therese
Pelletier, Daniel

DIVISION DEAN

DeMarkey, Nina

FACULTY

Adams, Virgil III
Badal, Gloria
Cavin, Robert “Greg”
Curiel, Larry
Dedic, James
Doak, Les
Flores, Michael
Floyd, Becky
Goralski, Craig
Halahmy, David
Heusser, Willis
Johnson, Susan
Lewis, Carol
Lind, Daniel
Martinez, Randall
Mathews, Eapen Peter
Mendoza, Armando
Odebunmi, Fola
Rhymes, Regina
Sandoval, Carlos
Seiling, Bryan
Sidhu, Parwinder
Young, Brandy
Zager, Gary

2012–2013 Administration and Faculty Accomplishments

Adams, Virgil III — *Human Services*

B.A., California State University, San Bernardino
M.A., Azusa Pacific University

Alexander, John — *Automotive Technology*

B.A., California State University, Long Beach

Armale, Ron — *Physics/Astronomy*

B.S., California State Polytechnic University, Pomona
M.S., Ph.D., University of California, Irvine

Ashburn, Shirley — *Nursing*

B.S.N., M.S., Ohio State University

Austin, Peggy Jean — *Librarian*

B.A., University of California, Davis
M.L.S., University of California, Los Angeles

Badal, Gloria — *Political Science*

A.A., Cypress College
B.A., M.A., California State University, Fullerton

Bandyopadhyay, Santanu — *Director, IR and Planning*

B.Sc., Calcutta University, India
M.B.A., Ph.D., Ohio University

Bartlett, Kimberly — *Director, Disabled Students Program and Services*

A.A., Glendale Community College, Glendale Arizona
B.A., Arizona State University
Ph.D., University of California, Santa Barbara

Beard, Michael — *Automotive Technology*

Bedard, Dana — *Counselor/Student Development*

B.A., University of California, San Diego
M.S., California State University, Long Beach

Beidler, Larry E. — *Physical Education*

A.A., Santa Ana College
B.A., California State University, Long Beach
M.Ed., Azusa Pacific University

Bernstein, Denise — *Nursing*

ADN, Cypress College
B.S.N., M.S.N., University of Phoenix

Beyer, George — *Music*

B.M., M.M., California State University, Fullerton

Blilie, Jeannie — *Psychiatric Technician*

RN, (MSN, PMH/NP) California State University, Long Beach

Boettger, Kathleen — *Mortuary Science*

B.A., California State University, Los Angeles
M.S., California State University, Fullerton

Borla, Linda — *English*

B.A., M.A., California State University, Sacramento

Bottiaux, Paul — *Physical Education, Student Activities*

B.S., Michigan State University
M.S., California State University, Fullerton

Bower, Glenn — *Mortuary Science*

B.A., California Lutheran University, Thousand Oaks
M.S., National University, San Diego

Boyce, Jane C. — *Psychiatric Technology*

B.S.N., California State University, Fullerton
M.S., California State University, Long Beach
Adult Nurse Practitioner

Brydges, Michael — *Communication Studies*

A.A., Mt. San Antonio College
B.A., M.A., California State University, Los Angeles

Cant, Karen — *Vice President*

A.A., Orange Coast College
B.A., California State University, Fullerton
M.A., California State University, Long Beach

Carrigan, Ting-Pi Joyce — *Division Dean, Fine Arts*

B.A., University of California, San Diego
M.A., University of California, Los Angeles

Carter, Kelly — *Counseling/Student Development*

A.A., Ricks College
B.S., Brigham Young University
M.A., California State University, Fresno

Castle, Victoria — *Geology*

A.A., Saddleback Community College, Mission Viejo
B.S., California State University, Los Angeles
M.B.A., Pepperdine University, Malibu

Cavin, Robert Greg — *Philosophy and Religious Studies*

B.A., University of Southern California
M.A., Fuller Theological Seminary
B.A., M.A., Ph.D., University of California, Irvine

Chi, Hong — *English as a Second Language/
Linguistics/Anthropology/Chinese*

M.A., M.S., State University of New York at Albany
Ph.D., Louisiana State University

Chiplunkar, Sujata — *Biology*

B.S., South Gujarat University, India
M.S., Ph.D., The Maharaja Sayajirau University of Baroda, India

Clark, Lisa — *Hospitality Management*

B.A., California State University, Sacramento

Contreras, Kendra — *Dental Hygiene*

R.D.H., B.S., University of Southern California
M.S., Kaplan University

Coopman, Jennifer — *Mathematics*

B.S., University of California, Los Angeles
M.S., California State University, Long Beach

Corrales, Nancy — *Diagnostic Medical Sonography*

A.R.R.T., C.R.T., A.R.D.M.S.
A.S., Long Beach City College
B.S., University Autonoma de Baja California

Curiel, Larry — *Sociology*

B.A., M.A., California State University, Fullerton

Daniels, Joan C. — *English*

A.A., Cypress College
B.A., M.A., California State University, Long Beach
J.D., Western State University, College of Law

De Coro, Helena — *Music*

B.A., M.A., California State University, Long Beach

de Dios, Paul — *Division Dean, Counseling and Student Development*

A.A., Cerritos College
B.A., University of California, Irvine
M.S., California State University, Long Beach

Dedic, James — *Sociology/Social Work*

B.A., M.A., California State University, Fullerton
M.S.W., University of Southern California

Dellinger, Patricia — *Computer Information Systems*

B.A., California State University, Long Beach

DeMarkey, Nina — *Division Dean, Social Sciences*

B.A., Northeastern Illinois University
M.A., Chapman University

De Roo, Robin — *Chemistry*

B.A., M.A., California State University, Fullerton

Deutsch, Nancy — *English/Reading*

A.A., Bee County College, Texas
B.A., Baylor University
M.A., California State University, Long Beach

Dickey, Cherie — *English/Reading*

B.A., M.A., California State University, Long Beach

Diep, Christie Rossier — *English*

A.A., Golden West
B.A., M.A., California State University, Fullerton

Doak, Leslie — *Geography*

B.A., Aurora University
M.A., California State University, Fullerton

Doman, Monica Maldonado — *Library*

B.A., M.L.S., University of California, Los Angeles

Donley, Steven R. — *Division Dean, Career Technical Education*

Eckenrode, Adam — *Mathematics*

B.A., M.S., California State Polytechnic University, Pomona

Faraci, Michael — *Nursing*

B.A., Central Connecticut State University

M.S.N., California State University, Los Angeles

D.N.P., Western University of Health Sciences

Fee, Richard — *Division Dean, Science, Engineering and Mathematics*

B.A., Colorado College

Ph.D., Pennsylvania State University

Fishman, Darlene C. — *Director, Nursing*

B.S.N., Medical College of Virginia School of Nursing

M.S.N., California State University, Los Angeles

Flores, Michael C. — *History*

B.A., California State University, Fullerton

M.A., California State University, Los Angeles

Ed.D., Argosy University, Orange County

Floyd, Becky D. — *Anthropology*

B.A., California State University, Fullerton

M.A., University of Montana

Forman, Mary K. — *English*

B.A., University of Rhode Island

M.F.A., University of Massachusetts

Franklin, Catherine — *Reading*

B.A., California State University, Long Beach

M.S., California State University, Fullerton

Franks, Joseph — *Psychiatric Technology*

A.A., Cypress College

B.A., M.A., California State University, Fullerton

Freer, Carolee — *Court Reporting*

A.A., Cerritos College

B.A., M.B.A., California State University, Fullerton

Certified Reporting Instructor, NCRA

Frey, Michael — *Astronomy, Physics*

B.S., University of Arizona

M.S., California State University, Long Beach

Frianeza, Michael — *Radiologic Technology*

A.R.R.T., C.R.T.

A.S., Cypress College

B.S.R.S., Midwestern State University

M.B.A., University of Phoenix

Frumkin, Sally — *Nursing*

A.S., East Los Angeles College

B.S.N., California State University, Los Angeles

M.S.N., California State University, Long Beach

Fujimoto, Janet — *English*

B.A., M.A., California State University, Fresno

Gabourie, Lillian (Penny) — *Honors Counselor/*

Transfer Center Director

B.A., California State University, Fullerton

M.S., University of LaVerne

Gallo, Joseph — *Music*

B.A., M.A., California State University, Los Angeles

Ganer, Patricia — *Communication Studies*

A.A., Cypress College

B.A., University of Southern California

M.A., University of California, Los Angeles

Ph.D., University of Utah

Giardina, Edward — *Fine Arts*

B.F.A., California State University, Fullerton

M.F.A., Vermont College — Norwich University

Gill, David — *Biology*

B.A., M.A., University of California, Santa Barbara

Ph.D., Cornell University

Gober, Joel R. — *Biology*

B.A., M.S., Ph.D., Southern Illinois University

Godshalk, Kathryn — *Mathematics*

B.A., California State University, Long Beach

M.A., California State University, Fullerton

M.S., University of Southern California

Gomez, Rebecca R. — *Health Information Technology*

B.S., University of California, Los Angeles

M.S., California State University, Long Beach

M.A., University of San Francisco

Goralski, Craig T. — *Anthropology*

A.A., Goldenwest College

B.A., M.A., California State University, Fullerton

Ph.D., Pennsylvania State University

Gotoh, Allison — *Chemistry*

B.S., M.S., Ph.D., University of California, Irvine

Grande, Jolena — *Mortuary Science*

A.S., Cypress College

B.S., University of Central Oklahoma

M.F.S., M.S., National University

Grantham, Robert — *Counselor/Student Development*

A.A., Fullerton College

B.A., University of California, Irvine

M.S.W., California State University, Long Beach

Green, Carol — *Dental Hygiene*

R.D.H., B.S., University of Southern California

R.D.H., M.A., California State University, Long Beach

Greico, Laura — *Radiologic Technology*

A.R.R.T., C.R.T.

A.S., Fullerton College

B.V.E., California State University, Long Beach

Halahmy, David G. — *History*

B.A., University of California, Los Angeles
M.A., California State University, Northridge

Han, Yongmi — *Manager, ISP*

B.A., University of California, Irvine
M.A., University of California, Santa Barbara

Harvey, Carol — *Nursing*

B.S.N., University of San Francisco
M.S.N., University of Nevada, Reno

Henry, Diane — *Division Dean,
Physical Education/Athletics*

A.A., Rio Hondo College
B.A., M.A., California State University, Long Beach
M.Ed., Azusa Pacific University

Herrera, E. Alexis — *Spanish*

B.A., M.A., University of Utah

Herzog, Anna — *Nursing*

A.A.S., Northampton County Area Community College
B.S.N., Kutztown University
M.S.N., California State University, Dominguez Hills

Heusser, Willis — *Philosophy and Religious Studies*

A.A., Pierce College
B.A., University of California, Los Angeles
M.A., University of Rochester, New York

Hock, Richard — *Air Conditioning/Refrigeration*

B.S., State University of New York, Fredonia, N.Y.
M.B.A., University of Phoenix

Holmes, Ian — *Media Arts Design*

B.F.A., Art Center College of Design, Pasadena

Hormel, James — *Theater Arts*

B.A., University of the Pacific, Stockton
M.F.A., University of California, Irvine

Howard, Stacey G. — *Counseling/Student Development
(Articulation Officer)*

B.A., California State University, Long Beach
M.A., California State University, Dominguez Hills

Izadi, Behzad

B.S., University of Washington, Seattle
M.S., University of California, Davis
Ph.D., Colorado State University, Fort Collins

Jaffray, Sarah — *History*

B.A., M.A., California State University, Long Beach

Jepson, Jane C. — *Counseling/Student Development*

B.A., Towson State University
M.S., California State University, Long Beach

Jianto, Susana — *Computer Information Systems*

B.S., University of Kansas
M.Ed., University of Texas at Austin

Johannsen, Tina — *Psych Tech*

B.S., M.S., California State University, Fullerton

Johnson, Michael L. — *Art*

B.A., M.A., California State University, Fullerton

Johnson, Robert — *Photography/Fine Arts*

B.A., California Lutheran University
M.A., M.F.A., California State University, Fullerton

Johnson, Susan — *Psychology*

B.A., University of North Carolina — Greensboro
M.A., Pepperdine University

Jones, Sarah — *Reading, Language Arts*

B.A., M.S., California State University, Fullerton

Kashi, Barbara — *Reading*

B.Ed., Seattle University
M.S., California State University, Fullerton

Kasler, Michael J. — *President*

B.A., M.S., California State University, Long Beach
M.S., Ed.D., Pepperdine University

Keel, Lawrence J. — *English*

B.A., University of Southern California
M.P.W., M.A., Ph.D., University of Southern California

Kishel, Patricia — *Marketing/Management*

B.A., M.F.A., University of California, Los Angeles
M.B.A., California State University, Long Beach

Klein, Susan — *English/Reading*

B.A., Westmont College, Santa Barbara
M.A., California State University, Los Angeles
M.A., California State University, Long Beach

Klyde, Michael — *Career Technical Education*

B.A., Industrial Arts
M.A., Occupational Studies

Koeppel, Liana — *Communication Studies*

B.A., San Diego State University
M.A., California State University, Northridge
Ph.D., University of Southern California

Kruse, Kathleen — *Nursing*

B.A., Occidental College
B.S.N., Washington State University
M.S.N., California State University, Los Angeles

Laguana-Ferinac, Renay — *Counseling/
Student Development*

B.A., California State University, Dominguez Hills
M.A., Pepperdine University

Lambros, John — *Communication Studies*

B.A., M.A., California State University, Long Beach

Landis, Lenore — *Chemistry*

B.S., California State University, Long Beach
M.S., University of California, Los Angeles

Landry, Erin — *Dance*

B.F.A., California Institute of the Arts
M.F.A., University of California, Irvine

Lawrence, Roberta — *Dental Hygiene*

R.D.H., Cypress College
R.D.H.A.P., West Los Angeles College
B.F., California State University, Fullerton

Lawson, Velia S. — *Counseling/Student Development*

B.A., University of California, Los Angeles
M.S., California State University, Los Angeles

Ledesma, Nicole — *Mathematics*

A.A., Saddleback College
B.A., M.A., California State University, Fullerton

Lee, Eunju — *Mathematics*

B.S., M.S., California State University, Long Beach

Lester, Clifford — *Photography*

B.A., Brooks Institute of Photography

Lewis, Carol P. — *History*

B.A., M.A., University of California, Riverside

Lind, Daniel Joseph — *Ethnic Studies*

B.A., Bowdoin College
M.P.S., Cornell University
M.A., Claremont Graduate University

Llanos, Kathleen — *English as a Second Language*

B.A., San Jose State University
M.A., TESOL Certificate, California State University, Fullerton

McAlister, Kathleen — *English*

B.A., University of California, Los Angeles
M.A., Brown University
C. Phil., University of California, Los Angeles

McCament, David — *Mortuary Science*

A.S., Cypress College
MFS, National University
B.A., National University

McKnight, Richard — *Computer Information Systems*

B.S., California State University, Long Beach
M.A., Chapman University

McNay, Sally — *Nursing*

B.S.N., M.S.N., California State University, Dominguez Hills
E.C.D., Grant MacEwan College

McPherson, Debra — *English as a Second Language*

M.A., Linguistics, University of Texas
TESOL, California State University, Fullerton

Majarian, Mark — *Theater Arts*

B.A., Pomona College
M.F.A., University of California, Los Angeles

Majid, Rosalie — *Health Information Technology*

B.S., University of Texas Medical Branch, Galveston

Mao, Chaolin — *Mathematics*

Ph.D., University of Southern California

Marquardt, Marcus — *Psych Tech*

A.A., A.S., Citrus College
B.A., M.A., California State University, Los Angeles

Marshall, Barbara — *English*

B.A., S.U.N.Y. at Buffalo
M.A., M.Ed., University of Hartford
Ph.D., University of California, Irvine

Martinez, Randall — *Psychology*

B.A., M.A., San Jose State
Ph.D., University of Utah

Mathews, Eapen Peter — *Political Science*

B.A., M.A., University of North Texas

Mendoza, Armando — *Geography*

B.A., University of Northern Colorado
M.S., Texas A&M University

Mercer, Robert R. — *Communications/Journalism*

A.A., East Los Angeles College
B.J., University of Missouri — Columbia
M.A., University of Oklahoma

Michelle, Deborah — *Counseling/*

Student Development/DSP&S
B.A., M.S., San Diego State University

Miller, Jeanne K., C.P.A. — *Accounting*

A.A., Pasadena City College
B.S., California State University, Los Angeles
M.B.A., California State Polytechnic University, Pomona

Mintzer, Alex — *Biology*

B.S., University of California, Irvine
Ph.D., University of Michigan

Mitts, T. Lynn — *Radiologic Technology*

A.R.R.T., C.R.T., A.R.D.M.S
B.S.R.T., Midwestern State University
M.A., California State University, Long Beach

Moady, Alireza — *Business*

B.A., Pars College
M.S., Florida Institute of Technology
Ph.D., United States International University

Mohr, Margaret — *Physical Education*

B.A., M.A., California State University, Long Beach

Morvan, Laurie — *Mathematics*

B.S., University of Illinois at Urbana-Champaign
M.S., California State University, Long Beach

Mosqueda-Ponce, Therese L. — *Counseling/
Student Development*

B.S., California State University, Fullerton
M.S., California State University, Los Angeles
Ph.D., United States International University

Mottershead, Allen — *Engineering/Physics/Mathematics*

B.S., University of Toronto, Canada
M.S., University of California, Berkeley

Meyer, Barbara Braden

B.A., Antioch College
M.F.A., California State University, Fullerton

Nabahani, Melanie — *English*

B.A., M.A., California State University, Fullerton

Nelson, Kristine — *Matriculation Manager*

A.A., East Los Angeles College
B.A., M.S., California State University, Los Angeles

Nusbaum, David — *Mathematics*

B.S., M.Ed., University of California, Los Angeles
M.S., University of California, Irvine

Odeunmi, Fola — *Economics*

B.A., Chapman University
M.A., California State University, Fullerton

Ogoshi, Fumio — *Biology*

B.A., University of San Diego
Ph.D., University of California, Irvine

Oliveira, A. Fernando — *Spanish/Portuguese*

M.A., University of California, Irvine

Orozco, Luciano M. — *Automotive*

B.A., California State University, Los Angeles

Pacheco, Elizabeth — *Dental Assisting*

A.A., Riverside Community College
B.V.E., M.Ed., California State University, San Bernardino

Paek, Sylvia — *Mathematics*

A.A., El Camino College
B.S., M.S., University of California, Irvine

Paiement, Paul — *Art*

B.F.A., Minneapolis College of Art and Design
M.F.A., University of Southern California

Palmisano, Michelle — *Biology*

B.E., Vanderbilt University
M.S., Ph.D., University of California, San Diego

Pashaie, Billy — *Librarian*

B.A., M.L.I.S., University of California, Los Angeles
M.A., California State University, Los Angeles

Patti, Joyce — *Art*

B.A., University of California, Los Angeles
M.F.A., Yale University

Payne, John — *Language Arts*

B.A., M.A., M.F.A., California State University, Long Beach

Peacock, Joyce — *Librarian*

M.L.S., University of Illinois, Urbana-Champaign
B.A., California State University, Long Beach

Pelachik, Patricia A. — *Computer Information Systems/
Office Administration*

B.B.A., Cleveland State University
M.B.E., Eastern Michigan University
M.S., Nova University

Pelletier, Daniel — *Counseling/Student Development*

A.A., Saddleback College
B.A., California State University, Fullerton
M.A., Azusa Pacific University

Peters, Jeremy — *Culinary Arts*

A.S., Orange Coast College

Pickler, Brad A. — *Physical Education*

A.A., Cypress College
B.S., California State University, Fullerton
M.S., California Lutheran College

Pickler, Scott — *Physical Education*

A.A., Cypress College
B.A., San Diego State University
M.S., California Lutheran College

Pinkham, William — *Physical Education*

B.S., California State University, Fullerton
M.A., United States International University

Plett, Christina — *Mathematics*

A.A., Fullerton College
B.A., California State University, Long Beach
M.S., University of California, Irvine

Porter, Deidre M. — *Counseling/Student Development*

B.A., University of California, Irvine
M.A., Loyola Marymount University

Puma, Jessica — *Spanish*

B.A., University of California, Los Angeles
M.A., University of California, Irvine

Putman, Elizabeth — *Nursing*

A.A., L.A. Harbor College
B.S.N., California State University, Long Beach
N.P., Harbor-UCLA
M.S.N., California State University, Long Beach

Rajab, Adel — *Biology*

B.S., M.S., California State University, Long Beach
Ed.D., University of California, Irvine and
University of California, Los Angeles

Ramos, Jaime — *Psych Tech*

M.S.N./Ed. RN, University of Phoenix

Ramos, Larry — *Auto Collision Repair*

A.A., Cypress College

Rams, Richard — *Division Dean,
Student Support Services*

B.A., University of California, Riverside
M.S.Ed., University of Kansas
Ed.D., University of California, Irvine

Reid, Kathryn — *Music*

B.M., Western Michigan University
M.M., D.M.A., University of Miami

Reiland, Kathleen — *Airline and Travel Careers*

B.S., University of San Francisco
M.A., California State University, San Marcos

Rhymes, Regina — *Sociology*

B.A., M.A., California State University, Fullerton
M.S., University of Phoenix

Robertson, Alison — *English as a Second Language*

B.A., California State University, Fullerton
MTESL, Arizona State University

Rosati, Stephanie —

A.A., Citrus College

Rosenberg, Stuart — *English*

B.A., California State University, Long Beach
M.P.W., University of Southern California

Saldana, Jesse — *Business/Computer Information Systems*

A.A., Fresno Community College
B.S., California State University, Fresno
M.B.A., California State University, Long Beach

Sallade, Douglas — *Air Conditioning/Refrigeration*

B.S.E.T., California Polytechnic University, San Luis Obispo

Sandoval, Carlos — *Psychology*

B.A., California State University, Fullerton
M.A., Pepperdine University

Sato, Dee Ann — *Biology*

B.S., University of Washington
M.S., University of California, Davis

Schulps, Molly — *Fine Arts*

M.F.A., California State University, Northridge

Sanchez-Duran, José Antonio — *Biology*

B.A., California State University, Fullerton
Ph.D., University of Missouri, Columbia

Sciacca, John — *Health Science Dean*

B.A., University of Massachusetts
M.P.H., University of Hawaii
M.A., Central Michigan University
Ph.D., Purdue University

Seiling, Bryan — *History*

B.A., M.A., University of Southern California

Shrout, Cynthia — *Mathematics*

B.S., Phillips University
M.A., California State University, Fullerton

Sidhu, Parwinder — *Economics*

B.A., M.S., Ph.D., Guru Nanak Dev University, India

Simpson, Bob — *Executive Vice President*

B.A., M.A., California State University, Fullerton
Ed.D., University of California, Los Angeles

Snook, Dan — *Automotive Collision*

A.A., Chaffey College

Sonne, Kathryn T. — *English*

B.A., M.A., Brigham Young University

Spooner, Stephanie — *Biology*

B.S., M.S., California State University, Long Beach

Ssensalo, Renee — *Counseling/Student Development*

B.A., M.S., California State University, Long Beach

Subramaniam, Brinda — *Physics/Engineering*

B.S., M.S., Ph.D., Jiwaji University, India

Swytak, Judy — *Nursing*

A.A., Golden West College
B.S.N., M.S.N., California State University, Dominguez Hills

Takahashi, K. Mariye — *Japanese*

B.A., M.A., University of California, Los Angeles

Talwar, Ambika — *English/Comparative Literature*

B.A., Lady Shri Ram College, Delhi University
M.A., Delhi University, Delhi, India
M.A., California State University, Fullerton

Tomooka, Craig — *Chemistry*

B.S., University of California, Irvine
M.S., Ph.D., California Institute of Technology

Urquidi, Carlos, P.E. — *Air Conditioning/Refrigeration*

B.S., California State University, Los Angeles

Valencia, Wendy — *Nursing*

B.S.N., California State University, Dominguez Hills
M.S.N., University of California, Los Angeles

Villaseñor, C. Doreen — *EOPS Counselor*

B.A., California State University, Fullerton
M.A., California State University, Dominguez Hills

Vo, Denise — *Counseling/Student Development*

B.A., California State University, Long Beach
M.S., National University

Wada, Kathryn — *English as a Second Language*

B.A., University of California, Irvine
M.A., California State University, Long Beach

Wahbe, Randa B. — *Comparative Literature*

B.A., California State University, Los Angeles
M.A., California State University, Fullerton
Ed.D., Argosy University, Orange

Walker, Jane — *Nursing*

ASN, Santa Ana College
B.A., California State University, Fullerton
M.S.N., California State University, Dominguez Hills

Wassenaar, David — *Dean, Admission and Records and Business/Computer Information Systems*

B.A., Calvin College
M.S.B.A., California Polytechnic State University, Pomona

Welliver, Nancy — *Physical Education*

B.A., California State University, Long Beach
M.Ed., Azusa Pacific University

Winckler, Janet M. — *Nursing Education*

B.S.N., Mt. St. Mary's College
M.N., University of California, Los Angeles

Woo, Donna L. — *Computer Information Systems/Office Administration*

B.A., M.A., Michigan State University

Wood, Jane — *English as a Second Language*

B.A., University of Michigan
M.A., California State University, Long Beach

Wu, Penn — *Computer Information Systems***Young, Brandy** — *Psychology*

B.A., University of California, Los Angeles
M.A., Ph.D., University of California, Irvine

Young, Eldon — *Division Dean, Language Arts*

B.A., University of California, Los Angeles
M.A., Loyola Marymount University

Zager, Gary — *Human Services*

B.A., M.S., California State University, Fullerton

Zakala, Carol A. — *Dental Hygiene*

A.A.S., Hudson Valley Community College
B.S., University of Bridgeport
M.S., State University of New York at Buffalo

Professors Emeritus

Allison, Minnie Mathematics
 Alvarez, Kathleen Nursing
 Atkinson, Thomas W. Business
 Axline, Donna Business/Math
 Azen, Robert Biology
 Baca, J. Anthony Physical Education
 Baldwin, William Computer Science
 Bales, Elbert N. Counseling
 Ball, Sheridan Music
 Barrier, Catherine Library
 Beamer, Edwin Counseling
 Bedard, Donald Vice President, Student Personnel Services
 Berger, Ellen Art
 Bilyeu, Dean Counseling
 Blanchard, Donald Automotive Technology
 Bloom, Barbara Health Science
 Boettger, Robert Mortuary Science
 Boyle, Joseph Political Science/History
 Broadwell, Ronald B. Music
 Brockert, Carolyn Psychiatric Technology
 Brown, Dana Health Information and Radiologic Technology
 Brown, Kaleta Dean, Fine Arts/Theater Arts
 Bruce, Kay Dean, Library and Instructional Development
 Bruce, Malcolm Computer Science
 Buchanan, John History
 Buckbee, Thomas Engineering Technology
 Burchfield, Jerry Photography
 Bush, Robert Aeronautics
 Byrnes, Nancy R. Dental Hygiene;
 Vice President, Educational Support and Planning
 Calhoun, Fred Counseling
 Campagna, Anna K. Nursing Education
 Campbell, Mary Business
 Campellone, Bonna Division Dean, Health Science
 Canova, Lawrence Psychology
 Capsuto, Michael Accounting
 Carlisle, Eugene History
 Centobene, William Chemistry
 Chamness, Robert Reading/English
 Chen, Helen Chemistry
 Chin, Penny Nursing
 Claffey, William J. Business
 Clay, Joan Nursing
 Cooney, Neill Philosophy
 Cooper, Thomas Counseling/Articulation
 Cooper, Will Sociology
 Coppess, Alice Nursing Education
 Cross, Robert Dental Technology

Dainko, John Auto Collision Repair
 Davis, Mary Kay Dental Assisting
 Dawson, Shirley Dental Assisting
 DeMallac, Gail French/ESL
 Dodson, Laurie Health Information Technology
 Dorn, Marian Physical Education
 Drake, David Photography
 Dudley, Nelson Art
 Easton, Sharon Counseling/Student Development
 Edwards, Cyril Sociology
 England, Jean Counseling/Student Development
 Felos, Charlene Art
 Florentine, Rose Ann Nursing
 Flynn, Russell Oceanography
 Foust, E. Bonita Anthropology
 Fraese, Jayne English
 Fraese, Ronald W. Social Science
 Freiman, Wayne Air Conditioning/Refrigeration
 Fried, Gladys Nursing Education
 Friess, Donna Communication Studies
 Geddes, Patricia English
 Gee, Carol Nursing Education
 Gibby, Cheryl Mathematics
 Gifford, Charles F. Aviation
 Glattly, Marilyn J. Dance; Dean, Fine Arts
 Gold, Stephen Mathematics
 Gorno, Ric Marketing/Management/Finance
 Green, Keith Geology
 Gross, Katherine G. Art
 Hall, Richard Biology
 Hannon, Andrea Division Dean, Health Science
 Harmon, Roger English
 Hardy, Robert Art
 Harkrider, James R. Biology
 Hayes-Williams, Jerrilyn Office Administration
 Heinze, Betty English
 Hickey, Dennis Philosophy
 Higgins, Jeanne Psychiatric Technology
 Hinkson, Kenneth Computer Information Systems
 Hoffmann, Nena L. Nursing Education
 Ida, Almira Nursing Education
 Isenberger, Janis Cook Physical Education
 Itnyre, Terry F. English
 Jackson, Ruth S. Speech
 Jacobs, Michael Division Dean, Fine Arts and SEM
 Jeffer, Marsha English
 Johnson, Don Physical Education
 Johnson, Rowena Business
 Jones, Anthony Auto Collision
 Jones, Francis L. Business
 Jones, Raymond Music

Kelly, Patricia	Dental Assisting	Phillips, James.....	Economics
Kelly, Henry.....	Nursing Education	Piburn, Elizabeth	Nursing
Killen, Brian	Psychology	Polizzi, Nick	Geography
Koike, Judy.....	Librarian	Polsky, Diana	Theater Arts
Koerper, Henry	Anthropology	Quinliven, Russ	Welding
Kolsky, Gail	Counseling	Ransom, Alan.....	Accounting
LaCour, Marshall	Photography	Rayl, Nancy.....	English
Lewis, Margie	President	Redman, Ronald P.	History/Spanish
Leyda, Jack	Music	Reeve, Thomas	Dean, Social Science
Licari, Charles.....	Reading/English	Ricci, Paul.....	Philosophy
Livsey, Gerry.....	Physical Education	Ricker, Marshall	Physics
Long, Jack.....	Business	Root, Alfred L.	Mathematics
Lubin, Thomas	Chemistry	Rossier, Roger.....	Counseling
Lucostic, James J.	History	Rubino, Kenneth J.	Physical Education
Maeda, Mits.....	Sociology	Russell, Barbara.....	Nursing
Marrs, Barbara.....	Division Dean, Language Arts	Rydalch, Ina.....	Dental Hygiene
McDaniel, Marian.....	Radiologic Technology	Sandore, Russell C.	Marine Technology
McDermott, Rosemary	Counseling	Schaefer, Sandra	Reading
McIntosh, Richard.....	Dean, Language Arts, A&R	Schick, Charlene.....	Economics
McLeod, Alexander	Social Science	Schiller, Carl	Physical Education
Maddox, Evelyn.....	Nursing Education	Selga, Max.....	Psychiatric Technology
Magnusson, Robert E.	History	Sever, Sue	Court Reporting
Manis, Armen	English	Sherard, Chuck.....	Automotive Technology
Masters, Gerald	Psychology	Simpson, Altus.....	Geology
Melom, Jane.....	Counseling	Siragusa, Chris	Mathematics
Mercadante, Larry	Physical Education	Smith, Glen.....	Automotive Service and Repair
Merickel, Karen.....	Biology	Smith, Larry.....	Mathematics
Metz, Douglas.....	Mortuary Science	Steckler, Albert.....	Counseling
Miller, Peggy	Psychiatric Technology	Stewart, James L.	Chemistry
Moran, Olga.....	Spanish	Stout, Byron.....	Mortuary Science
Morrison, Joan.....	Nursing Education	Svendsen, William.....	Speech
Myres, Brian	Biology	Taylor, Joann.....	Dental Hygiene
Nordee, Thomas.....	Counseling/Student Development	Tobler, Hank.....	Division Dean, Business and Vo Tech
O'Brien, Noreen	Nursing	Trulock, Ron.....	Air Conditioning/Refrigeration
O'Brien, Patrick.....	Language Arts	Tyrrell, Don	Counseling
Oda, Sam.....	Automotive Service and Repair	Ueberroth, Jene	English
Olson, Diana	Nursing	Van Voorhis, Richard	Physical Education
Oravetz, Orpha.....	Nursing Education	Vandergrift, Robert.....	Biology
Ortiz, Louis	Counseling	VonSoosten, Ron.....	Computer Information Services
Owens, Cynthia.....	Counseling	Vosbein, Brenda.....	Psychiatric Technology
Page, JoAnne M.	Counseling	Walston, Wilbur	Biology
Page, Ruthanna	Hospitality/Travel Careers	Weber, John.....	English
Paris, Vincent.....	Culinary Arts	Welsh, Carol	Dean, Library and Learning Resource Center
Park, Willis.....	Geography	Whiteside, Dorothy.....	Nursing Education
Payne, Alice	Counseling/Student Development	Williams, Susan	Nursing
Parmenter, Susan.....	Staff Development/English	Wilson, Margaret S.	Nursing
Parmenter, William.....	Dean, Counseling	Wood, Arthur.....	Counseling
Pearl, Carl.....	Economics	Wood, Jane.....	ESL
Pearson, Ola Faye	Medical Record Technology	Woodall, Edgar H.	Business
Pecchia, Leonard T.	Physical Education	Yamada, Mitsuye M.	English
Petrie, David	Mathematics		

Quick Guide to Help You

SERVICE/OFFICE	LOCATION	TELEPHONE
Admissions and Records	Student Center	484-7346
Add and Drop		484-7346
Application		484-7346
Graduation		484-7346
Residency		484-7346
Transcripts		484-7346
Veterans Resource Center		484-7150
Adult Re-entry	Student Center, 2nd Floor	484-7120
Assessment Center	Student Center, 2nd Floor	484-7223
Associated Students	Student Activities Center	484-7198
Clubs and Organizations, Student Government		
Athletics	Gym II Bldg, 1st Floor, Room 107	484-7352
Sports Information		484-7356
Bookstore	Bookstore, 1st Floor	484-7336
Bursar's Office	Student Center	484-7317
CalWORKs	Cypress College Complex, 2nd Floor, Room 201	484-7237
Campus Safety	CCE3	484-7387
Emergencies, Lost and Found, Parking		
24/7 Cell Number		493-6687
CARE	Cypress College Complex, 2nd Floor, Room 201	484-7237
Career Planning Center	Student Center, 2nd Floor	484-7120
Charger Chronicle	Fine Arts Bldg, 1st Floor	484-7267
Counseling Service Areas		
Business and CIS	Business Bldg, 2nd Floor	484-7015
Career Planning/Adult Re-entry	Career Center, Student Center, 2nd Floor	484-7120
Career Technical Education	Tech Ed I Bldg, 2nd Floor, Room 205	484-7015
Counseling Center	Student Center, 2nd Floor	484-7015
Fine Arts	Student Center, 2nd Floor	484-7015
Health Science	Tech Ed III (Health Science) Bldg, 2nd Floor	484-7015
Language Arts	Student Center, 2nd Floor	484-7015
Physical Education	Gym II Bldg, 1st Floor, Room 107B	484-7015
Science, Engineering and Mathematics	Science/Math Bldg, 2nd Floor, Room 211	484-7015
Social Sciences	Student Center, 2nd Floor	484-7015
Transfer Center	Transfer Center, Student Center, 2nd Floor	484-7123
Disabled Students Program & Services (DSPS)	Cypress College Complex, 1st Floor	484-7104
Distance Education/Online		484-7052
Division Offices		
Business	Business Bldg, 2nd Floor	484-7211
Career Technical Education (Vocational)	Tech Ed I Bldg, 2nd Floor	484-7231
Counseling and Student Development	Student Center, 2nd Floor	484-7334
Fine Arts	Fine Arts Bldg, 2nd Floor	484-7139
Health Science	Tech Ed III (Health Science) Bldg, 2nd Floor	484-7283
Language Arts	Humanities Bldg, 2nd Floor, Room 240	484-7169
Library/Learning Resources	LLRC, 2nd Floor, Room 239	484-7000 x48381
Physical Education	Gym II Bldg, 1st Floor, Room 107	484-7352
Science, Engineering and Mathematics	Science/Math Bldg, 2nd Floor, Room 208	484-7153
Social Sciences	Humanities Bldg, 2nd Floor, Room 238	484-7185
Student Support Services	Cypress College Complex, 2nd Floor, Room 218	484-7371

Additional information about most of these services can be found in the Student Services section of this schedule.

SERVICE/OFFICE	LOCATION	TELEPHONE
English as a Second Language	Humanities Bldg, 2nd Floor, Room 240	484-7169
EOPS	Cypress College Complex, 2nd Floor	484-7368
Extended Day Office	Faculty and Staff Service Center (M–Th 4:00 pm–9:00 pm) Evening Administrator (M–Th 5:00 pm–9:00 pm)	484-7332 484-7333
Facilities Reservations and Rentals	Cypress College Complex, 3rd Floor	484-7388
Financial Aid	Cypress College Complex, 1st Floor	484-7114
Food Services — Charger Café	Student Center, 1st Floor	484-7227
Foundation	Cypress College Complex, 3rd Floor	484-7126
Scholarships		
Guardian Scholars	Cypress College Complex, 2nd Floor (Dean's Office)	484-7374
Health Services	Gym II Bldg, 1st Floor	484-7361
Honors Program/Service Learning Program	Student Center, 2nd Floor	484-7452
Instruction Office	Cypress College Complex, 3rd Floor	484-7329
International Students	Student Activities, Bldg 8, 1st Floor	484-7050
Center for Intercultural Understanding		
I-20 Forms		
Language Lab	Library/Learning Resource Center, 1st Floor	484-7193
Legacy Program	Humanities Bldg, 2nd Floor, Room 246	484-7000 x48455
Library	Library/Learning Resource Center, 2nd Floor	484-7000 x48381
Learning Resource Center	Library/Learning Resource Center, 1st Floor	484-7000 x48381
Math/Science Learning Center	Library/Learning Resource Center, 1st Floor, Room 127	484-7151
Matriculation	Student Center, 2nd Floor	484-7230
Online Education		484-7052
Puente Program	Student Center, 2nd Floor	484-7015
School of Continuing Education	Continuing Ed., Bldg 14, Room 5 (Off of Lot 4)	484-7038
Student Services Outreach	Cypress College Complex, 2nd Floor, Room 218	484-7371
Student Activities	Student Activities Center	484-7199
Student Discipline	Student Center, 2nd Floor, Room 213	484-7334
Study Abroad	Fine Arts Bldg, 2nd Floor, Room 200	484-7139
Supplemental Instruction	Library/Learning Resource Center, 1st Floor, Room 105	484-7322
Teacher Preparation Program	Humanities Bldg, 2nd Floor, Room 238	484-7185
Teacher Preparation Counseling	Student Center, 2nd Floor	484-7015
TRAC	Cypress College Complex, 2nd Floor, Room 201	484-7237
Transfer Center	Student Center, 2nd Floor	484-7129
Tutorial Center	Library/Learning Resource Center, 1st Floor	484-7183
UTAP	Humanities Bldg, 2nd Floor, Room 248	484-7129

Additional information about most of these services can be found in the Student Services section of this schedule.

Index

Index

A

AB540	6
Absences	10
Academic Achievement Clubs	39
Academic Calendar 2012–2013	3
Academic Distinction	10
Academic Freedom	8, 45
Academic Honesty	9
Academic Honors	10
Academic Policies	8
Academic Renewal Policy	10
Accounting	71
Address Change	12
Administration and Faculty Accomplishments	294
Administration and Organizational Structure	288
Administration of Justice	73
Administrative Procedures	40
Administrative Procedures 5500 — Standards of Student Conduct and Discipline	40
Administrative Procedures 5500 — Student Discipline Procedures	41
Admissions and Records	32
Admissions Requirements	6
Adult Re-Entry Program	32
Advanced Placement (AP), College Level Exam Program (CLEP), International Baccalaureate (IB)	15
Advanced Placement Credit	10
Advisory Definition	69
Air Conditioning and Refrigeration	73
Airline and Travel Careers	78
Alpha Gamma Sigma Honor Society	27
Anthropology	84
AP (Advanced Placement)	16
Appeals and Petitions	21
Application for an Associate Degree	51
Application for Certificates	50
Application for Graduation	51
Art	86
Articulation Statement	32

Asian Studies	89
Assessment	7
Assessment Center	32
Associate Degree Graduation Requirements for Cypress College	55
Associate Degrees	50
Associate Degrees for Transfer	59
Associated Students Benefits Program	7
Astronomy	89
Athletic Eligibility	39
Attendance	10
Auditing	11
Automotive Collision Repair	90
Automotive Technology	95
Aviation	104

B

Baccalaureate Degrees	56
Basic Skills	20
Biology	109
Bookstore	32
Bursar	33
Business Administration	112
Business and Computer Information Systems Lab	25

C

California Basic Educational Skills Test (CBEST)	31
California Subject Examinations for Teachers (CSET)	35
CalWORKS	34
Campus Clubs	38
Campus ID Card	7
Campus Life	38
Campus Safety	33
Career Planning Center	33
Catalog Rights	11
Center for Intercultural Understanding (CIU)	34
Certificate Programs	48
Challenging Prerequisites, Corequisites, or Other Limitations on Enrollment	11
Chemistry	114
Chinese	115
Class Cancellations	12

Class Transfers 12

Classification of Students. 23

Clubs 38

College Level Examination Program (CLEP) Scores
Applied to General Education 17

Communication Studies (formerly Speech) 116

Computer Information Systems 118

Computer Science 131

Computing Resources Acceptable Use Policy 12

Continuing Education Program 132

Continuing Students. 7

Continuous Enrollment. 13

Cooperative Agencies Resources for Education (CARE)
Programs and Services 35

Core Values of Cypress College 4

Corrections to Student Information. 13

Counseling 140 C 34

Counseling and Student Development 34, 132

Counseling/Orientation. 7

Course Double Counting 13

Course Numbering. 13

Course Offerings 26

Course Progression 13

Course Repeat Adjustment. 13

Course Repetition 13

Court Reporting 134

Credit by Examination 14

CSU General Education Breadth Requirements. 59

CSULB (ITEP) Elementary Program and CSUF (STEP)
Elementary Program 31

Cultural Clubs 38

Cultural Diversity 55

Cypress College Vision Statement 4

Cypress College Biology Majors Course Sequence 110

Cypress College Institutional Learning Outcomes 5

Cypress College Transcripts 24

D

Dean's List. 10

Dental Assistant. 147

Dental Hygiene 150

Dentistry 154

Department Certificates. 50

Departmental/Area Majors 59

Description of Courses. 65

Diagnostic Medical Sonography 154

Disabled Students Program and Services (DSPS) 34

Disabled Veterans 38

Discipline Procedures 41

Distance Education Program 25

Dress Code 39

E

Economics 157

Education 158

Electives Definition 70

Electricity. 159

Engineering 159

Engineering Technology 161

English 162

English as a Second Language 25, 167

Enrollment Fees. 8

Enrollment Limitation. 23

Ethnic Studies 170

Examinations. 14

Extended Opportunity Programs and Services (EOPS). 34

External Exam Credit 15

F

F-2 Dependents. 28

Faculty. 287

Family Educational Rights and Privacy Act 47

Fees 7

FERPA 47

Financial Aid 35

Food Services — Campus Dining 36

Foreign Language 173

Foundation. 36

French. 173

G

General Education and Basic Skills Program Learning Outcomes . . .	66
General Education Certification (GE) and Pass Along	65
General Education Requirements for the Associate Degree	52
Geography	174
Geology	177
Grade Change	19
Grade Reports	19
Grades and Grade Point Average	19
Grading System	19
Graduation Requirements	50
Grounds for Challenge	11
Guardian Scholars	36

H

Health Fee	8
Health Information Technology	178
Health Science	183
Health Science — Continuing Education	185
Health Services	36
High School Transcripts	23
History	185
Honors at Entrance	10
Honors Program	27
Hotel, Restaurant, Culinary Arts	189
How To Earn a Vocational Certificate	48
How To Earn an Associate Degree	50
How To Transfer to a Four-Year College	55
Human Services	194, 197
Hybrid Courses	26

I

IB (International Baccalaureate) Examination Credit	20
Industrial Education Teaching	199
Instructional Divisions	291
Instructional Support Services	26
Inter-Club Council (ICC)	39
Intercollegiate Athletic Program	39
Interdisciplinary Studies	200
International Baccalaureate (IB)	18
International Students	28

International Transcript Evaluations	20
Intersegmental General Education Transfer Curriculum (IGETC)	62

J

Japanese	201
Journalism/Communications	203

L

Learning and Academic Resources	205
Legacy Program	29
Liberal Arts Degree with a Specified Department/Area Major	58
Liberal Arts Degree with Area of Emphasis	55
Liberal Studies	204
Library	205
Library and Learning Resource Center	26
Lost and Found	36

M

Management	205
Marine Service Technician	211
Marketing	212
Mathematics	22, 215
Matriculation	36
Media Arts Design	219
Medicine	226
Merchandising	226
Mortuary Science	228
Multimedia	231
Music	232
myGateway	7

N

New Students	7
Non-Degree Credit Courses (Basic Skills)	20
Non-Discrimination Statement	46
Non-Resident Tuition	8
Nursing Program	238

O

Occupational Degree	51
Office Administration	245

Official Student Publications 39
 Online Courses 26
 Open Enrollment Policy 6
 Open-Entry Courses 25
 Optometry 246

P

Parking 8, 33
 Parking Enforcement and Appeals 33
 Pass/No Pass Grading 20
 Pathway I: Associate Degree and/or CSU/IGETC Transfer Curriculum 5
 Pathway II: Career and Technical Education Certification 5
 Pathway III: Personal, Academic, and Professional Development 6
 Patrons of the Arts 37
 Petitions and Appeals 21
 Pharmacy 246
 Philosophy and Religious Studies 246
 Photography 248
 Physical Education 253
 Physical Science 262
 Physical Therapy 263
 Physician Assistant 263
 Physics 263
 Political Science 264
 Portuguese 266
 Pre-Collegiate Basic Skills Courses 22
 Pre-Professional Programs 266
 President’s List 10
 Privacy Release 23
 Probation and Dismissal Policies 21
 Procedures 39, 40
 Procedures During Registration 22
 Professors Emeritus 302
 Proficiency Examination 22
 Programs of Study 48
 Psychiatric Technology 267
 Psychology 269
 Publications 39
 Puente Program 29

R

Radiologic Technology 272
 Reading 21
 Reading Proficiency 55
 Readmission After Scholastic Dismissal 22
 Real Estate 276
 Recreation 276
 Refund Processing Fee 8
 Refunds 8
 Registration 7
 Remedial Limitation 22
 Repeated Classes 38
 Returning Students 7
 Review and Release of Student Information 23

S

Semester Courses 25
 Service Charge 8
 Service Learning 30
 Short Term Courses 25
 Social Sciences 277
 Sociology 278
 Spanish 280
 Special Admit Program 30
 Special Programs 27
 Standards for Scholastic Dismissal 21
 Student Activities 40
 Student Government 40
 Student Grievances 39
 Student Housing 37
 Student Representation Fee 8
 Student Responsibility 11
 Student Right to Know Campus Security Act 46
 Student Rights and Responsibilities 45
 Student Rights under FERPA for Postsecondary Institutions 47
 Student Support Services 32
 Study Abroad Program 31
 Study Load 23
 Summer Intersession Courses 25
 Supplemental Instruction 27

T

Teacher Preparation Program	31
Teaching Credential Preparation	31
Theater Arts	282
Title IX and Civil Rights Grievances	46
Transcript Fees	8
Transcripts	24, 38
Transfer Alliances	27
Transfer Center	37
Transfer Credit — Baccalaureate Degrees	65
Transfer Programs	55

U

Unofficial Publications	40
-----------------------------------	----

V

Verification of Enrollment/Student Status	8
Veteran Dependent Exemption	38
Veterans Academic Progress	38
Veterans and Service Members	37
Veterans Military Service Connected Benefit Programs	37
Veterinary Medicine	285
Victims of Sexual Assault	46
Vision Statement	4

W

Welding	285
What is FERPA?	47
Withdrawal	24
Work Experience	286

Welcome to Cypress College



For updated information, visit the campus Web site at <http://www.CypressCollege.edu>.

Buildings	Service Locations
AN Anaheim Campus	Administration COCPLEX
BK Bookstore	Admissions & Records SC
BUS Business	Assessment SC
COCPLEX 6 Cypress College Complex	Bookstore BK
FA Fine Arts	Busstop SC
G1 Gymnasium 1	Campus Safety (*) BUS
G2 Gymnasium 2	Counseling Center SC
H Humanities	ISSPS COCPLEX
L/LRC Library/Learning Resource	EOPS COCPLEX
M&O Maintenance & Operations	Financial Aid COCPLEX
SAC Student Activities	Food Services SC
SC Student Center	Health Center G2
SEM Science/Engineering/Math	International Students SAC
TA Theater Arts	Information SC
TE1 Technical Education 1	Locker Rooms TE2
TE2 Technical Education 2	Photo ID SC
TE3 Technical Education 3/Health Science	

Cypress College
 9200 Valley View Street
 Cypress, CA 90630
 (714) 484-7000
<http://www.CypressCollege.edu>

- S** = Stairs
- E** = Elevator
- ☎** = Emergency Phone
- 📶** = WiFi Internet
- P** = Parking Permit Vending Machine
- Ⓞ** = Temporary parking area as needed for overflow.

Minds. Motivated. • Change. Activated. • Excellence. Elevated. • Greatness. Achieved.

Cypress College

School of Continuing Education

Fullerton College

NOCCCD

Dr. Robert Simpson,
President,
Cypress College

Dr. Ned Doffoney, Chancellor,
North Orange County
Community College District

Board of Trustees:

Jeffrey P. Brown; Barbara Dunsheath;
Leonard L. Lahtiner; Michael B.
Matsuda; Molly McClanahan; Donna
Miller; M. Tony Ontiveros

Student Trustees: Alie McCaskill,
Cypress College; Gabriel Botello,
Fullerton College



For nearly a half-million students, Cypress College has been a springboard to their dreams.

Come to Cypress College and Motivate Your Mind!